

Features

- Phase jitter filter for PCIe® 2.0 application
- Four pairs of HCSL PCIe 2.0 Differential Clocks
- Prop delay $< \pm 250$ ps (in PLL mode)
- Low skew < 50 ps
- Low jitter < 50 ps cycle-to-cycle
- < 1 ps additive RMS phase jitter
- 100 MHz PLL Mode operation
- 3.3V operation
- Packaging (Pb-free and Green):
 - 20-Pin 4.0mm x 4.0mm x0.75mm TQFN (ZD20)

Description

Pericom Semiconductor's PI6PCIEB24 is a PCI Express® (PCIe) 2.0 compliant high-speed, low-noise differential clock buffer. The device distributes the input differential PCIe clock to four differential pairs of clock outputs with zero delay PLL.

Block Diagram

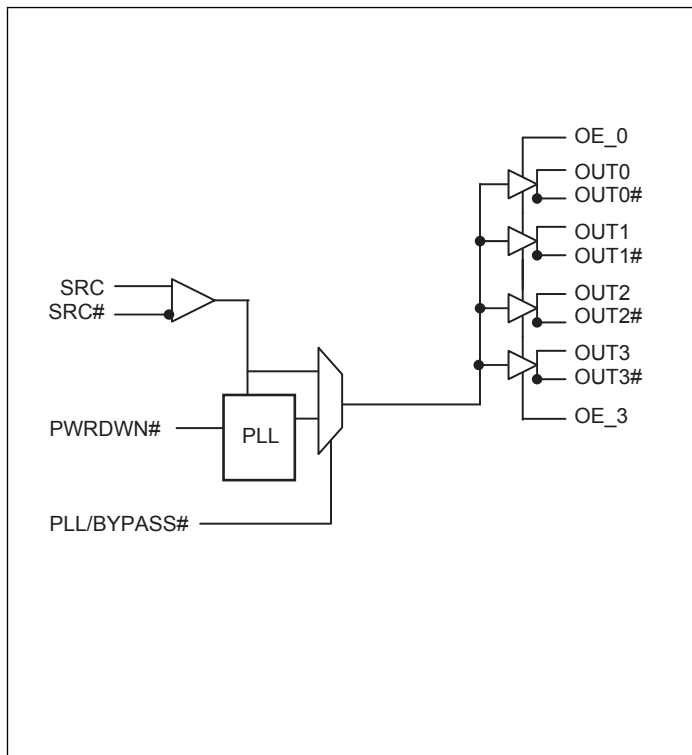

Pin Configuration

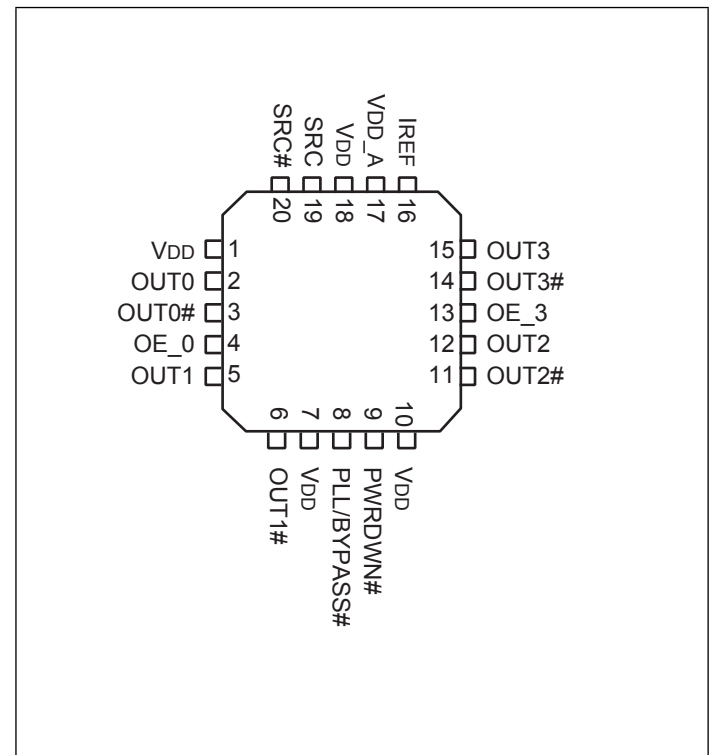

Pin Descriptions

Pin Name	Type	Pin No	Description
SRC & SRC#	Input	19, 20	0.7V Differential SRC input from PI6C410 clock synthesizer
OUT[0:3] & OUT[0:3]#	Output	2, 3, 5, 6, 12, 11, 15, 14	0.7V Differential outputs
IREF	Input	16	External resistor connection to set the differential output current
V _{DD}	Power	1, 7, 10, 18	3.3V Power Supply for Outputs
PWRDWN#	Input	9	3.3V LVTTTL active LOW input for power down operation
VDD_A	Power	17	3.3V Power Supply for PLL
PLL/BYPASS#	Input	8	When HIGH, PLL is enabled, When LOW, PLL is bypassed.
OE_0, OE_3	Input	4, 13	When HIGH, enables corresponding OUT0, OUT3 respectively.

Ground connection is through the package metal plate underneath.

Functionality

PWRDWN#	OUT	OUT#
1	Normal	Normal
0	$I_{REF} \times 2$	Low

Power Down (PWRDWN# assertion)

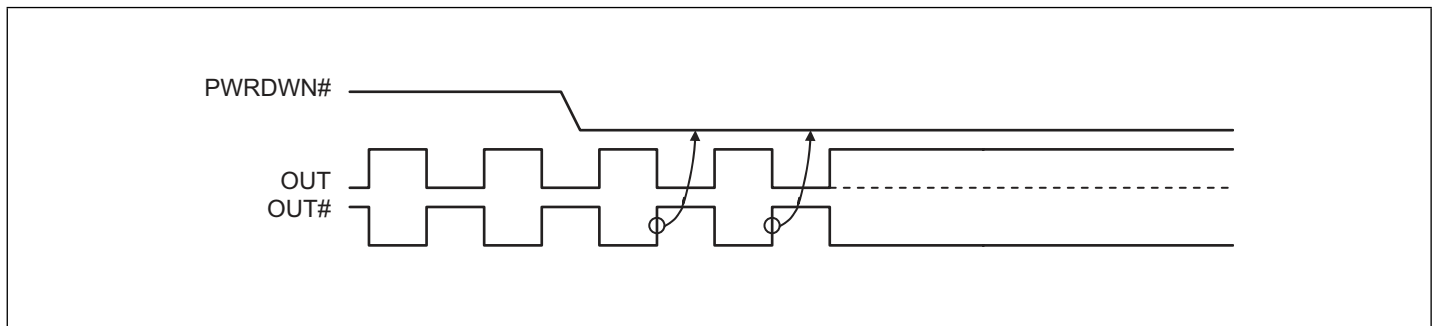

Figure 1. Power down sequence

When PWRDWN# is asserted (Low), $2xI_{REF}$ current flows through OUT pin.

Power Down (PWRDWN# De-assertion)

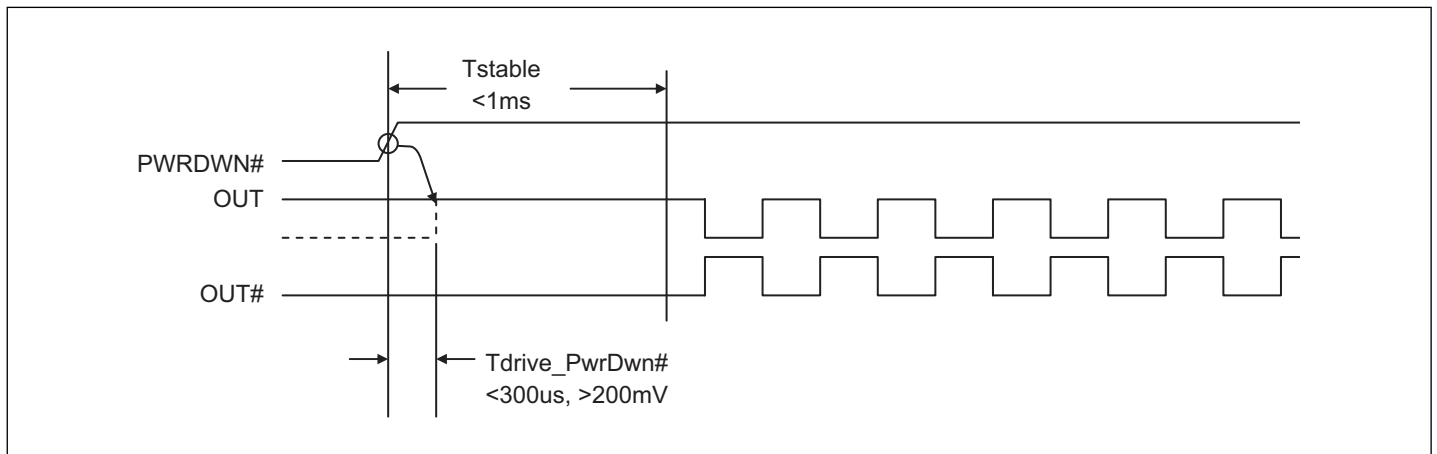

Figure 2. Power down de-assert sequence

Current-mode output buffer characteristics of OUT[0:3], OUT[0:3]#

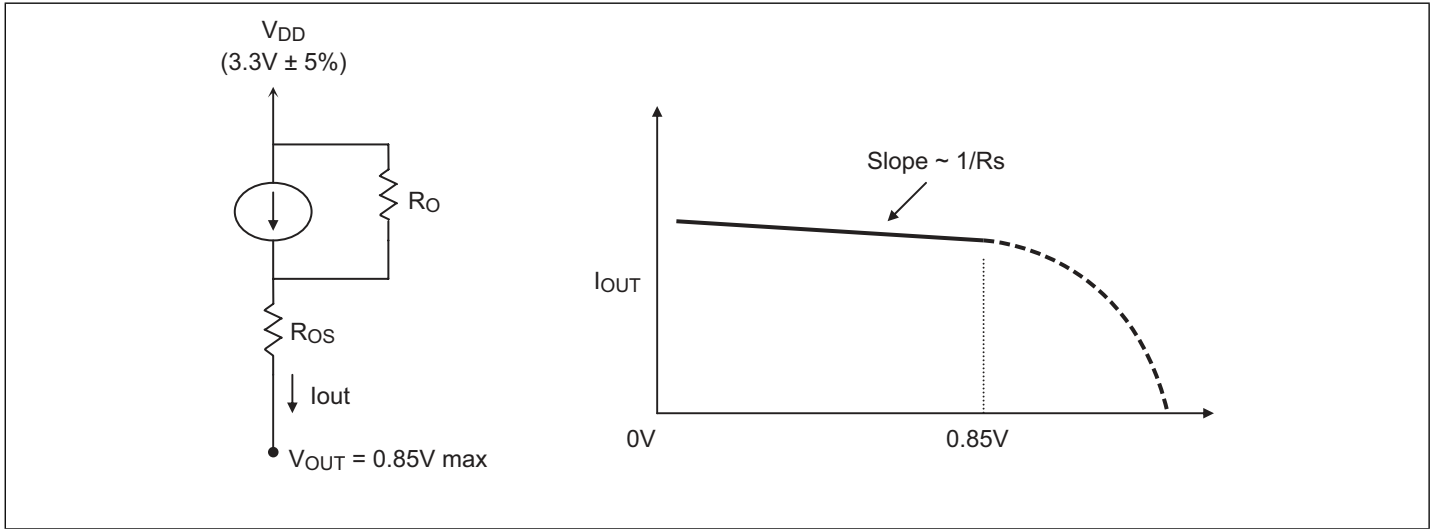

Figure 2. Simplified diagram of current-mode output buffer

Differential Clock Buffer characteristics

Symbol	Minimum	Maximum
RO	3000Ω	N/A
ROS	unspecified	unspecified
VOUT	N/A	850mV

Current Accuracy

Symbol	Conditions	Configuration	Load	Min.	Max.
IOUT	VDD = 3.30 ±5%	RREF = 475Ω 1% IREF = 2.32mA	Nominal test load for given configuration	-12% INOMINAL	+12% INOMINAL

INOMINAL refers to the expected current based on the configuration of the device.

Differential Clock Output Current

Board Target Trace/Term Z	Reference R, Iref = VDD/(3xRr)	Output Current	VOH @ Z
100Ω (100Ω differential ≈ 15% coupling ratio)	RREF = 475Ω 1%, IREF = 2.32mA	IOH = 6 x IREF	0.7V @ 50

Absolute Maximum Ratings (Over operating free-air temperature range)

Symbol	Parameters	Min.	Max.	Units
V _{DD_A}	3.3V Core Supply Voltage	-0.5	4.6	V
V _{DD}	3.3V I/O Supply Voltage	-0.5	4.6	
V _{IH}	Input High Voltage		4.6	
V _{IL}	Input Low Voltage	-0.5		
T _s	Storage Temperature	-65	150	°C
V _{ESD}	ESD Protection	2000		V

Stress beyond those listed under “Absolute Maximum Ratings” may cause permanent damage to the device.

DC Electrical Characteristics (V_{DD} = 3.3±5%, V_{DD_A} = 3.3±5%)

Symbol	Parameters	Condition	Min.	Max.	Units
V _{DD_A}	3.3V Core Supply Voltage		3.135	3.465	V
V _{DD}	3.3V I/O Supply Voltage		3.135	3.465	
V _{IH}	3.3V Input High Voltage	V _{DD}	2.0	V _{DD} + 0.3	
V _{IL}	3.3V Input Low Voltage		V _{SS} - 0.3	0.8	
I _{IK}	Input Leakage Current	0 < V _{IN} < V _{DD}	-5	+5	μA
I _{OH}	Output High Current	I _{OH} = 6 x I _{REF} , I _{REF} = 2.32mA	12.2	15.6	mA
C _{IN}	Input Pin Capacitance		3	5	pF
C _{OUT}	Output Pin Capacitance			6	
LPIN	Pin Inductance			7	nH
I _{DD}	Power Supply Current	V _{DD} = 3.465V, F _{CPU} = 100MHz		200	mA
I _{SS}	Power Down Current	Driven outputs		40	
T _A	Ambient Temperature		-45	85	°C

AC Switching Characteristics ($V_{DD} = 3.3 \pm 5\%$, $V_{DD_A} = 3.3 \pm 5\%$)

Symbol	Parameters	Min	Max.	Units	Notes
F_{IN}		95	105	MHz	
T_{rise} / T_{fall}	Rise and Fall Time (measured between 0.175V to 0.525V)	175	700	ps	2
DT_{rise} / DT_{fall}	Rise and Fall Time Variation		125	ps	2
	Rise/Fall Matching		20	%	2
T_{pd}	PLL Mode (PLL/BYPASS# = 1)		± 250	ps	
T_{jitter}	Cycle - Cycle Jitter		50	ps	3, 4
V_{HIGH}	Voltage High including overshoot	660	1150	mV	2
V_{LOW}	Voltage Low including undershoot	-300		mV	2
V_{cross}	Absolute crossing point voltages	250	550	mV	2
ΔV_{cross}	Total Variation of V_{cross} over all edges		140	mV	2
T_{DC}	Duty Cycle	45	55	%	3
T_{jadd}	Additive RMS phase jitter for PCIe GenII	<0	1	ps	5
$T_{pd}(bypass)$	Bypass mode (PLL/BYPASS# = 0)	2.5	6.5	ns	

1. Test configuration is $R_s = 33.2\Omega$, $R_p = 49.9\Omega$, and 2pF.
2. Measurement taken from Single Ended waveform.
3. Measurement taken from Differential waveform.
4. Measurement taken using M1 data capture analysis tool.
5. Additive jitter is calculated from input and output RMS phase jitter using PCIe 2.0 filter by $T_{jadd} = \sqrt{(\text{output jitter})^2 - (\text{input jitter})^2}$

Configuration Test Load Board Termination

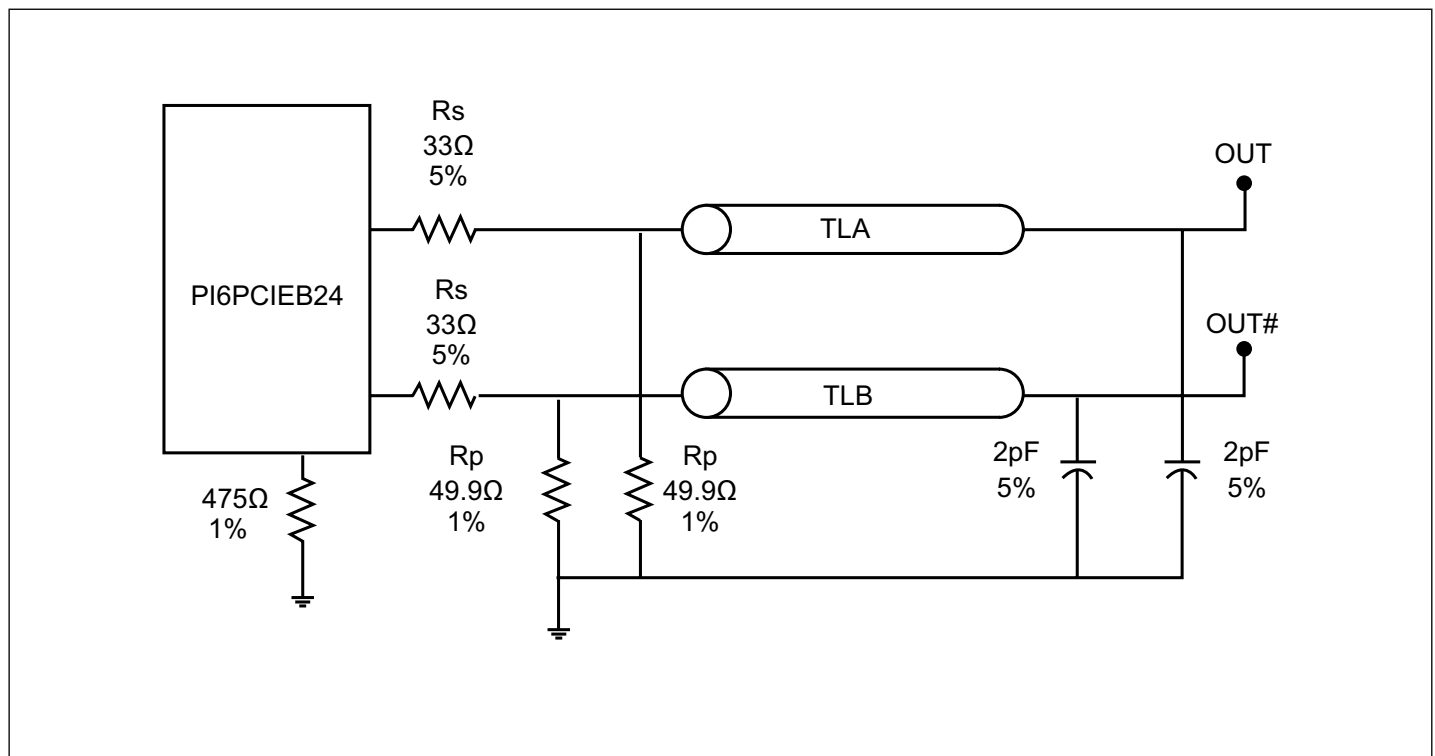

Packaging Mechanical: 20-Pin TQFN (ZD)

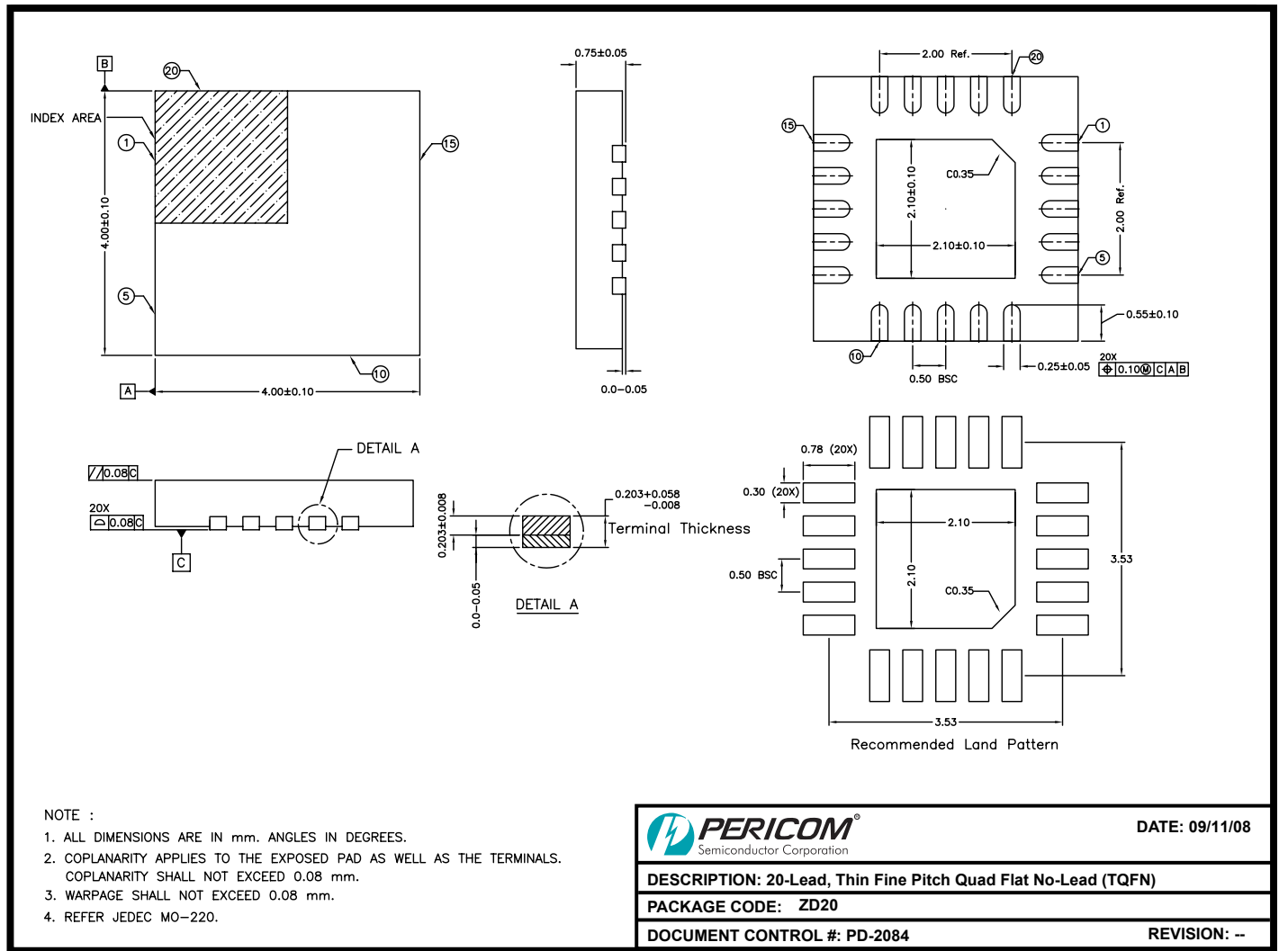

08-0456

Ordering Information⁽¹⁻³⁾

Ordering Code	Package Code	Package Description
PI6PCIEB24ZDE	ZD	20-pin, 4.0mm x 4.0mm, TQFN, Pb-Free and Green

1. Thermal characteristics can be found on the company web site at www.pericom.com/packaging/
2. E = Pb-free and Green
3. Adding an X suffix = Tape/Reel