

FEATURES

- 3.3V and 5V power supply options
- Up to 1.5Gbps operation
- Low power
- Low noise
- Chatter-Free /LOS Generation
- PECL /LOS Output
- TTL /EN Input
- Differential PECL inputs for data
- /EN input is TTL with internal 27K pull up
- Single power supply
- Designed for use with Micrel-Synergy laser diode driver and controller
- Available in a tiny 10-pin (3mm) MSOP

DESCRIPTION

The SY88913V limiting post amplifier with its high gain and wide bandwidth is ideal for use as a post amplifier in fiber-optic receivers with data rates up to 1.5Gbps. Signals as small as 5mVp-p can be amplified to drive devices with PECL inputs. The SY88913V generates a chatter-free PECL Loss of Signal (/LOS) output.

The SY88913V incorporates a programmable level detect function to identify when the input signal has been lost. This information can be fed back to the /EN input of the device to maintain stability under loss of signal conditions. Using LOS_{LVL} pin the sensitivity of the level detect can be adjusted. The LOS_{LVL} voltage can be set by connecting a resistor divider between V_{CC} and V_{REF} . Figure 2, Figure 3 and 4 show the relationship between input level sensitivity and the voltage set on LOS_{LVL} .

APPLICATIONS

- 1.25Gbps Gigabit Ethernet
- 531Mbps and 1062Mbps Fibre Channel
- 622Mbps SONET
- Gigabit Interface Converter

BLOCK DIAGRAM

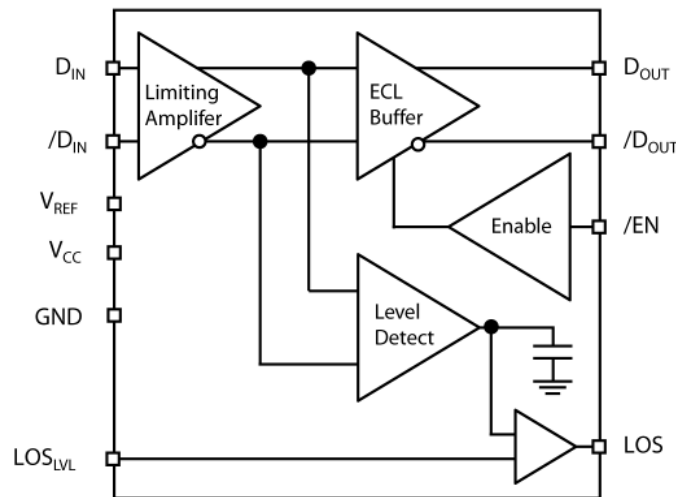

PACKAGE/ORDERING INFORMATION

Ordering Information

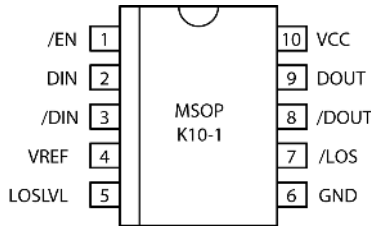

16-Pin MSOP (K10-1)

Part Number	Package Type	Operating Range	Package Marking	Lead Finish
SY88913VKC	K10-1	Commercial	913V	Sn-Pb
SY88913VKCTR ⁽¹⁾	K10-1	Commercial	913V	Sn-Pb
SY88913VKG	K10-1	Industrial	913V with Pb-Free bar-line indicator	Pb-Free NiPdAu
SY88913VKGTR ⁽¹⁾	K10-1	Industrial	913V with Pb-Free bar-line indicator	Pb-Free NiPdAu

Note:

- 1. Tape and Reel.

PIN NAMES

Pin	Type	Function
D _{IN}	Data Input	Data Input
/D _{IN}	Data Input	Inverting Data Input
LOS _{LVL}	Input	Loss of Signal Level Set
/EN	TTL Input	Output Enable (active Low)
/LOS	PECL Output	Loss of Signal Indicator (active Low)
GND	Ground	Ground
D _{OUT}	PECL Output	Data Output
/D _{OUT}	PECL Output	Inverting Data Output
V _{CC}	Power Supply	Positive Power Supply
V _{REF}	Output	Reference Voltage Output for LOS Level Set (see Fig. 2)

GENERAL DESCRIPTION

General

The SY88913V is an integrated limiting amplifier intended for high-frequency fiber-optic applications. The circuit connects to typical transimpedance amplifiers found within a fiber-optics link. The linear signal output from a transimpedance amplifier can contain significant amounts of noise, and may vary in amplitude over time. The SY88913V limiting amplifier quantizes the signal and outputs a voltage-limited waveform.

The TTL /EN pin allows the user to disable the signal without removing the input signal.

ABSOLUTE MAXIMUM RATINGS⁽¹⁾

Symbol	Rating	Value	Unit
V_{CC}	Power Supply Voltage	0 to +7.0	V
D_{IN} , $/D_{IN}$	Input Voltage	0 to V_{CC}	V
D_{OUT} , $/D_{OUT}$, $/LOS$	Output Voltage (with 50 Ω load)	$V_{CC} - 2.5$ to $V_{CC} + 0.3$	V
LOS_{LVL}	Input Voltage	0 to V_{CC}	V
V_{REF}	Output Voltage	$V_{CC} - 2.0$ to V_{CC}	V
T_A	Operating Temperature Range	-40 to +85	°C
T_{store}	Storage Temperature Range	-55 to +125	°C
$T_{JUNCTION}$	Max Junction Temperature	125	°C

Note:

1. Permanent device damage may occur if absolute maximum ratings are exceeded. This is a stress rating only and functional operation is not implied at conditions other than those detailed in the operational sections of this data sheet. Exposure to absolute maximum rating conditions for extended periods may affect device reliability.

DC ELECTRICAL CHARACTERISTICS
 $V_{CC} = +3.3V \pm 10\%$ or $+5V \pm 10\%$, $R_{LOAD} = 50\Omega$ to $V_{CC} - 2V$

Symbol	Parameter	$T_A = -40^\circ\text{C}$		$T_A = 0^\circ\text{C}$		$T_A = +25^\circ\text{C}$			$T_A = +85^\circ\text{C}$		Unit	
		Min.	Max.	Min.	Max.	Min.	Typ.	Max.	Min.	Max.		
I_{CC}	Power Supply Current ⁽¹⁾	5V	—	35	—	35	—	21	35	—	40	mA
		3.3V	—	35	—	35	—	23	35	—	40	
I_{IL}	/EN Input LOW Current	-0.3 ⁽⁵⁾	—	-0.3 ⁽⁵⁾	—	-0.3 ⁽⁵⁾	—	—	-0.3 ⁽⁵⁾	—	—	mA
I_{IH}	/EN Input HIGH Current	—	20 ⁽²⁾	—	20 ⁽²⁾	—	—	20 ⁽²⁾	—	20 ⁽²⁾	—	μA
		—	100 ⁽³⁾	—	100 ⁽³⁾	—	—	100 ⁽³⁾	—	100 ⁽³⁾	—	100 ⁽³⁾
V_{CMR}	Common Mode Range	GND +2.0	$V_{CC} - 1.0$	GND +2.0	$V_{CC} - 1.0$	GND +2.0	—	$V_{CC} - 1.0$	GND +2.0	$V_{CC} - 1.0$	V	
V_{offset}	Differential Output Offset	—	± 160	—	± 160	—	± 40	± 160	—	± 160	mV	
LOS_{LVL}	LOS_{LVL} Level	V_{REF}	V_{CC}	V_{REF}	V_{CC}	V_{REF}	—	V_{CC}	V_{REF}	V_{CC}	V	
V_{OH}	D_{OUT} and $/D_{OUT}$ HIGH Output	$V_{CC} - 1085$	$V_{CC} - 880$	$V_{CC} - 1025$	$V_{CC} - 880$	$V_{CC} - 1025$	$V_{CC} - 955$	$V_{CC} - 880$	$V_{CC} - 1025$	$V_{CC} - 880$	mV	
V_{OL}	D_{OUT} and $/D_{OUT}$ LOW Output	$V_{CC} - 1830$	$V_{CC} - 1555$	$V_{CC} - 1810$	$V_{CC} - 1620$	$V_{CC} - 1810$	$V_{CC} - 1705$	$V_{CC} - 1620$	$V_{CC} - 1810$	$V_{CC} - 1620$	mV	
V_{REF}	Reference Supply ⁽⁴⁾	$V_{CC} - 1.38$	$V_{CC} - 1.26$	$V_{CC} - 1.38$	$V_{CC} - 1.26$	$V_{CC} - 1.38$	$V_{CC} - 1.32$	$V_{CC} - 1.26$	$V_{CC} - 1.38$	$V_{CC} - 1.26$	V	
V_{IH}	/EN Input HIGH Voltage	2.0	—	2.0	—	2.0	—	—	2.0	—	V	
V_{IL}	/EN Input LOW Voltage	—	0.8	—	0.8	—	—	0.8	—	0.8	V	

Notes:

1. No Output Load.
2. $V_{IN} = 2.7V$.
3. $V_{IN} = V_{CC}$.
4. I_{REF} must be limited to be within -0.8mA (source) and 0.5mA (sink).
5. $V_{IN} = 0.5V$.

AC ELECTRICAL CHARACTERISTICS

$V_{CC} = +3.3V \pm 10\%$ or $+5V \pm 10\%$, $R_{LOAD} = 50\Omega$ to $V_{CC} - 2V$.

Symbol	Parameter	$T_A = -40^\circ\text{C}$		$T_A = 0^\circ\text{C}$		$T_A = +25^\circ\text{C}$			$T_A = +85^\circ\text{C}$		Unit	Conditions
		Min.	Max.	Min.	Max.	Min.	Typ.	Max.	Min.	Max.		
PSRR	Power Supply ⁽¹⁾ Rejection Ratio	—	—	—	—	—	35	—	—	—	dB	Input referred, 55MHz
V_{ID}	Input Voltage Range	5	1800	5	1800	5	—	1800	5	1800	mV_{PP}	
V_{OD}	Differential Output Voltage Swing ⁽²⁾	— 200	—	— 200	—	— 200	700 250	—	— 200	—	mV mV	$V_{ID} = 15mV_{PP}$ $V_{ID} = 5mV_{PP}$
t_{OFFL}	/LOS Release Time ⁽³⁾ Minimum Input	—	0.5	—	0.5	—	0.1	0.5	—	0.5	μs	
t_{ONL}	/LOS Assert Time ⁽³⁾	—	0.5	—	0.5	—	0.2	0.5	—	0.5	μs	
t_{OFFH}	/LOS Release Time ⁽⁴⁾ Maximum Input	—	0.5	—	0.5	—	0.1	0.5	—	0.5	μs	
V_{SR}	/LOS Sensitivity Range	5	50	5	50	5	—	50	5	50	mV_{PP}	
HYS	/LOS Hysteresis	2	8	2	8	2	4.6	8	2	8	dB	
t_r, t_f	Output Rise/Fall Time	— —	260 —	— —	260 —	— —	170 t_{rin}, t_{fin}	260 —	— —	260 —	ps	$V_{ID} > 100mV_{PP}$ $V_{ID} < 100mV_{PP}$

Notes:

1. Input referred noise = RMS output noise/low frequency gain.
2. Input is 622MHz square wave.
3. Input is a 200MHz square wave, $t_r < 300\text{ps}$, $8mV_{PP}$.
4. Input is a 200MHz square wave, $t_r < 300\text{ps}$, $1.8V_{PP}$.

APPLICATION NOTE

Output Termination

The SY88913V outputs must be terminated with a 50Ω load to $V_{CC} - 2V$ (or Thevenin equivalent).

Layout and PCB Design

Since the SY88913V is a high-frequency component, performance can largely be determined by board layout and design. A common problem with high-gain amplifiers is feedback from the large swing outputs to the input via the power supply.

The SY88913V ground pin should be connected to the circuit board ground. Use multiple PCB vias close to the part to connect to ground. Avoid long, inductive runs which can degrade performance.

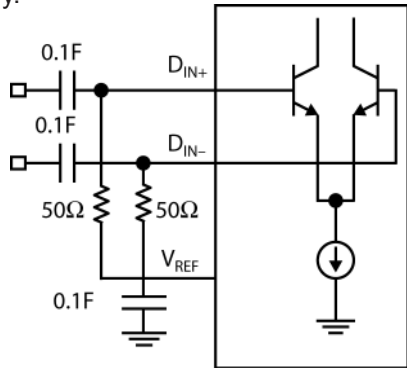

Figure 1. Differential Input Configuration

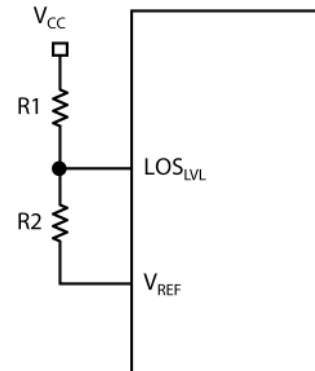

Figure 2. LOS_{LVL} Circuit

Notes:

$$LOS_{LVL} = V_{CC} - 1.32 + \frac{R2 \times 1.32}{R1 + R2}$$

$$R1 + R2 \geq 5k\Omega$$

PERFORMANCE CURVE

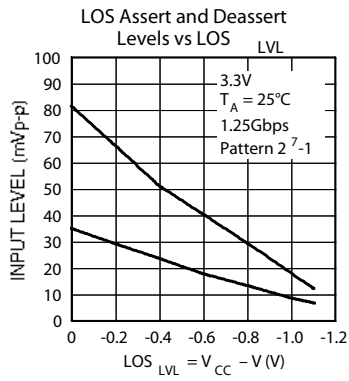

Figure 3. 3.3V LOS Assert and Deassert Levels vs. LOS_{LVL}

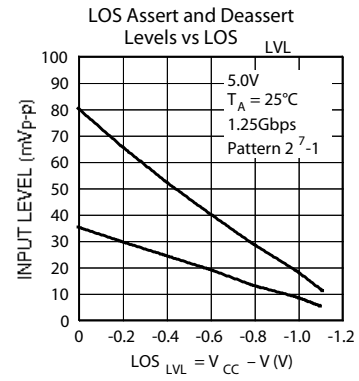
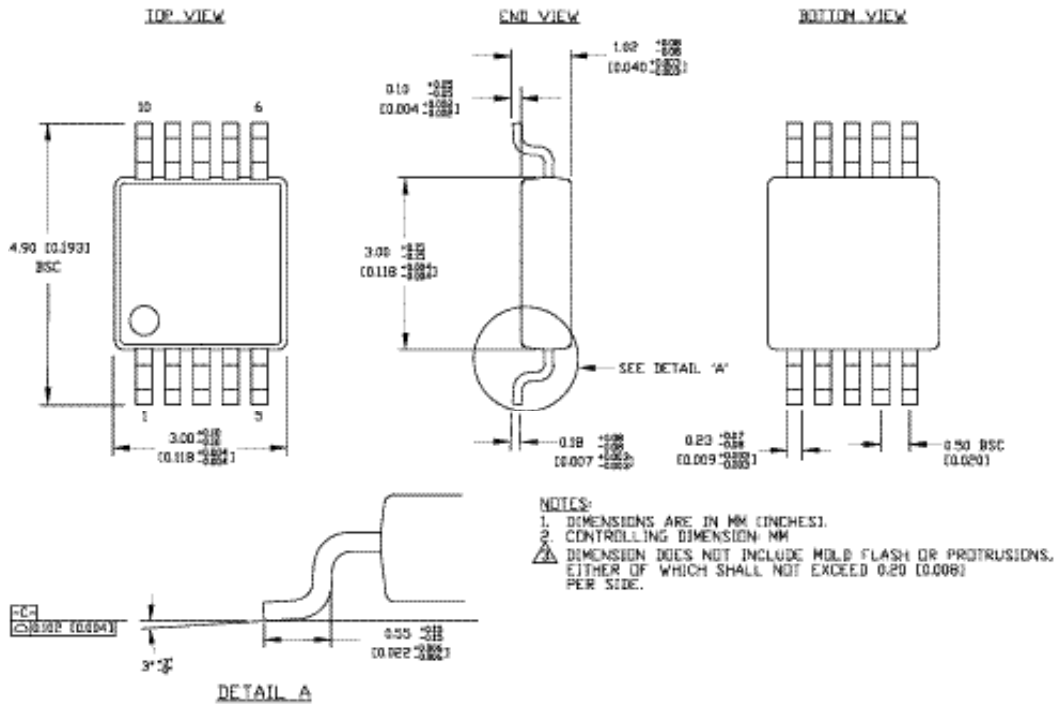

Figure 4. 5.0V LOS Assert and Deassert Levels vs. LOS_{LVL}

10 LEAD MSOP (K10-1)



Rev. 00

MICREL, INC. 2180 FORTUNE DRIVE SAN JOSE, CA 95131 USA

TEL + 1 (408) 944-0800 FAX + 1 (408) 474-1000 WEB <http://www.micrel.com>

The information furnished by Micrel in this data sheet is believed to be accurate and reliable. However, no responsibility is assumed by Micrel for its use. Micrel reserves the right to change circuitry and specifications at any time without notification to the customer.

Micrel Products are not designed or authorized for use as components in life support appliances, devices or systems where malfunction of a product can reasonably be expected to result in personal injury. Life support devices or systems are devices or systems that (a) are intended for surgical implant into the body or (b) support or sustain life, and whose failure to perform can be reasonably expected to result in a significant injury to the user. A Purchaser's use or sale of Micrel Products for use in life support appliances, devices or systems is at Purchaser's own risk and Purchaser agrees to fully indemnify Micrel for any damages resulting from such use or sale.

© 2005 Micrel, Incorporated.