

AD8331/AD8332/AD8334

FEATURES

Ultralow noise preamplifier (preamp)

Voltage noise = 0.74 nV/ $\sqrt{\text{Hz}}$

Current noise = 2.5 pA/ $\sqrt{\text{Hz}}$

3 dB bandwidth

AD8331: 120 MHz

AD8332, AD8334: 100 MHz

Low power

AD8331: 125 mW/channel

AD8332, AD8334: 145 mW/channel

Wide gain range with programmable postamp

–4.5 dB to +43.5 dB in LO gain mode

7.5 dB to 55.5 dB in HI gain mode

Low output-referred noise: 48 nV/ $\sqrt{\text{Hz}}$ typical

Active input impedance matching

Optimized for 10-bit/12-bit ADCs

Selectable output clamping level

Single 5 V supply operation

AD8332 and AD8334 available in lead frame chip scale package

APPLICATIONS

Ultrasound and sonar time-gain controls

High performance automatic gain control (AGC) systems

I/Q signal processing

High speed, dual ADC drivers

GENERAL DESCRIPTION

The AD8331/AD8332/AD8334 are single-, dual-, and quad-channel, ultralow noise linear-in-dB, variable gain amplifiers (VGAs). Optimized for ultrasound systems, they are usable as a low noise variable gain element at frequencies up to 120 MHz.

Included in each channel are an ultralow noise preamp (LNA), an X-AMP[®] VGA with 48 dB of gain range, and a selectable gain postamp with adjustable output limiting. The LNA gain is 19 dB with a single-ended input and differential outputs. Using a single resistor, the LNA input impedance can be adjusted to match a signal source without compromising noise performance.

The 48 dB gain range of the VGA makes these devices suitable for a variety of applications. Excellent bandwidth uniformity is maintained across the entire range. The gain control interface provides precise linear-in-dB scaling of 50 dB/V for control voltages between 40 mV and 1 V. Factory trim ensures excellent part-to-part and channel-to-channel gain matching.

Rev. G

Information furnished by Analog Devices is believed to be accurate and reliable. However, no responsibility is assumed by Analog Devices for its use, nor for any infringements of patents or other rights of third parties that may result from its use. Specifications subject to change without notice. No license is granted by implication or otherwise under any patent or patent rights of Analog Devices. Trademarks and registered trademarks are the property of their respective owners.

FUNCTIONAL BLOCK DIAGRAM

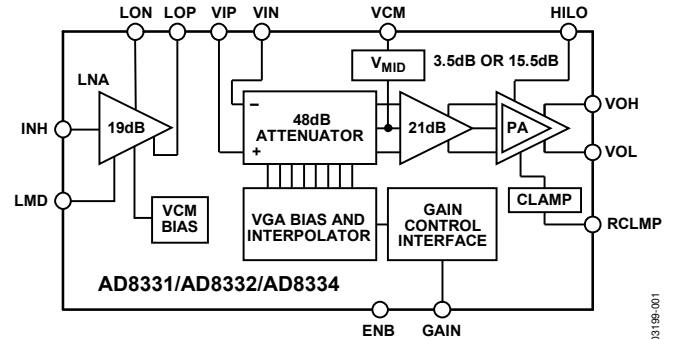

Figure 1. Signal Path Block Diagram

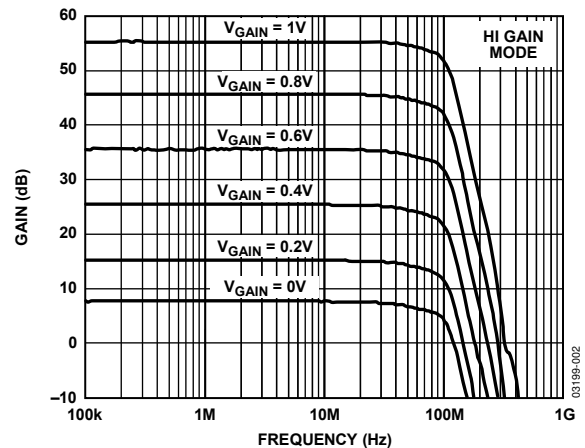

Figure 2. Frequency Response vs. Gain

Differential signal paths result in superb second- and third-order distortion performance and low crosstalk.

The low output-referred noise of the VGA is advantageous in driving high speed differential ADCs. The gain of the postamp can be pin selected to 3.5 dB or 15.5 dB to optimize gain range and output noise for 12-bit or 10-bit converter applications. The output can be limited to a user-selected clamping level, preventing input overload to a subsequent ADC. An external resistor adjusts the clamping level.

The operating temperature range is -40°C to $+85^{\circ}\text{C}$. The AD8331 is available in a 20-lead QSOP package, the AD8332 is available in 28-lead TSSOP and 32-lead LFCSP packages, and the AD8334 is available in a 64-lead LFCSP package.

TABLE OF CONTENTS

Features	1	Ultrasound TGC Application	34
Applications.....	1	High Density Quad Layout	34
General Description	1	AD8331 Evaluation Board	39
Functional Block Diagram	1	General Description.....	39
Revision History	2	User-Supplied Optional Components	39
Specifications.....	4	Measurement Setup.....	39
Absolute Maximum Ratings.....	7	Board Layout.....	39
ESD Caution.....	7	AD8331 Evaluation Board Schematics.....	40
Pin Configurations and Function Descriptions	8	AD8331 Evaluation Board PCB Layers	42
Typical Performance Characteristics	12	AD8332 Evaluation Board	43
Test Circuits.....	20	General Description.....	43
Measurement Considerations	20	User-Supplied Optional Components	43
Theory of Operation	24	Measurement Setup.....	43
Overview.....	24	Board Layout.....	43
Low Noise Amplifier (LNA)	25	Evaluation Board Schematics	44
Variable Gain Amplifier	27	AD8332 Evaluation Board PCB Layers	46
Postamplifier	28	AD8334 Evaluation Board	47
Applications Information	30	General Description.....	47
LNA—External Components.....	30	Configuring the Input Impedance	48
Driving ADCs	32	Measurement Setup.....	48
Overload	32	Board Layout.....	48
Optional Input Overload Protection	32	Evaluation Board Schematics	49
Layout, Grounding, and Bypassing.....	33	AD8334 Evaluation Board PCB Layers	51
Multiple Input Matching	33	Outline Dimensions	53
Disabling the LNA.....	33	Ordering Guide	55
REVISION HISTORY		Deleted AD8331 Bill of Materials Section and Table 11; Renumbered Sequentially	43
10/10—Rev. F to Rev. G		Changes to Figure 104	43
Changes to Quiescent Current per Channel Parameter, Table 1	6	Changes to Figure 106	45
Changes to Pin 1, Table 3.....	8	Changes to Figure 107	46
Changes to Pin 1 and Pin 28, Table 4 and Pin 4 and Pin 5, Table 5	9	Changes to Figure 113	47
Changes to Figure 6 and Table 6.....	10	Changes to Figure 114 and Board Layout Section	48
Changes to Figure 33.....	16	Deleted AD8332 Bill of Materials Section and Table 13; Renumbered Sequentially	48
Changes to Figure 64.....	22	Changes to Figure 115	49
Changes to Figure 70.....	24	Changes to Figure 116	50
Changes to Low Noise Amplifier (LNA) Section and Figure 74	25	Changes to Figure 117 to Figure 120	51
Changes to Figure 94.....	38	Changes to Figure 121	52
Changes to General Descriptions Section, Figure 95 Caption, Table 10, and Board Layout Section.....	39	Deleted AD8334 Bill of Materials Section and Table 15; Renumbered Sequentially	54
Changes to Figure 96.....	40		
Changes to Figure 97.....	41		
Changes to Figure 98 and Figure 103.....	42		

4/08—Rev. E to Rev. F

Changed R_{FB} to R_{IZ} Throughout	4
Changes to Figure 1.....	1
Changes to Table 1, LNA and VGA Characteristics, Output Offset Voltage, Conditions	4
Changes to Quiescent Current per Channel and Power Down Current Parameters	6
Changes to Table 2	7
Changes to Table 3, Pin 1 Description	8
Changes to Table 4, Pin 1 and Pin 28 Descriptions	9
Changes to Table 5, Pin 4 and Pin 5 Descriptions	9
Changes to Table 6, Pin 2, Pin 15, and Pin 20 Descriptions.....	10
Changes to Table 6, Pin 61 Description	11
Changes to Typical Performance Characteristics Section, Default Conditions.....	12
Changes to Figure 25	15
Changes to Figure 39	17
Changes to Figure 55 Through Figure 68	20
Changes to Theory of Operation, Overview Section	24
Changes to Low Noise Amplifier Section and Figure 74	25
Changes to Active Impedance Matching Section, Figure 75, and Figure 77	26
Changes to Figure 78	27
Changes to Equation 6, Table 7, Figure 81, and Figure 82.....	30
Changes to Figure 83	31
Changes to Figure 88	32
Switched Figure 89 and Figure 90	33
Changes to Figure 89	33
Changes to Ultrasound TGC Application Section.....	34
Incorporated AD8331-EVAL Data Sheet, Rev. A	39
Changes to User-Supplied Optional Components Section and Measurement Setup Section.....	39
Changes to Figure 95	39
Changes to Figure 97	41
Added Figure 98	42
Incorporated AD8332-EVALZ Data Sheet, Rev. D.....	44
Incorporated AD8334-EVAL Data Sheet, Rev. 0	49
Updated Outline Dimensions.....	55
Changes to Ordering Guide.....	57
4/06—Rev. D to Rev. E	
Added AD8334	Universal
Changes to Figure 1 and Figure 2.....	1
Changes to Table 1	4
Changes to Table 2	7
Changes to Figure 7 through Figure 9 and Figure 12.....	12
Changes to Figure 13, Figure 14, Figure 16, and Figure 18	13

Changes to Figure 23 and Figure 24	14
Changes to Figure 25 through Figure 27.....	15
Changes to Figure 31 and Figure 33 through Figure 36	16
Changes to Figure 37 through Figure 42.....	17
Changes to Figure 43, Figure 44, and Figure 48.....	18
Changes to Figure 49, Figure 50, and Figure 54.....	19
Inserted Figure 56 and Figure 57	20
Inserted Figure 58, Figure 59, and Figure 61	21
Changes to Figure 60	21
Inserted Figure 63 and Figure 65	22
Changes to Figure 64	22
Moved Measurement Considerations Section	23
Inserted Figure 67 and Figure 68	23
Inserted Figure 70 and Figure 71	24
Change to Figure 72	24
Changes to Figure 73 and Low Noise Amplifier Section.....	25
Changes to Postamplifier Section	28
Changes to Figure 80	29
Changes to LNA—External Components Section.....	30
Changes to Logic Inputs—ENB, MODE, and HILO Section ...	31
Changes to Output Decoupling and Overload Sections.....	32
Changes to Layout, Grounding, and Bypassing Section.....	33
Changes to Ultrasound TGC Application Section	34
Added High Density Quad Layout Section	34
Inserted Figure 94	38
Updated Outline Dimensions.....	39
Changes to Ordering Guide.....	40

3/06—Rev. C to Rev. D

Updated Format	Universal
Changes to Features and General Description.....	1
Changes to Table 1	3
Changes to Table 2	6
Changes to Ordering Guide.....	34

11/03—Rev. B to Rev. C

Addition of New Part.....	Universal
Changes to Figures.....	Universal
Updated Outline Dimensions.....	32

5/03—Rev. A to Rev. B

Edits to Ordering Guide.....	32
Edits to Ultrasound TGC Application Section	25
Added Figure 71, Figure 72, and Figure 73.....	26
Updated Outline Dimensions.....	31

2/03—Rev. 0 to Rev. A

Edits to Ordering Guide.....	32
------------------------------	----

AD8331/AD8332/AD8334

SPECIFICATIONS

$T_A = 25^\circ\text{C}$, $V_S = 5\text{ V}$, $R_L = 500\ \Omega$, $R_S = R_{IN} = 50\ \Omega$, $R_{IZ} = 280\ \Omega$, $C_{SH} = 22\text{ pF}$, $f = 10\text{ MHz}$, $R_{CLMP} = \infty$, $C_L = 1\text{ pF}$, VCM pin floating, -4.5 dB to $+43.5\text{ dB}$ gain (HILO = LO), and differential output voltage, unless otherwise specified.

Table 1.

Parameter	Test Conditions/Comments	Min	Typ	Max	Unit ¹
LNA CHARACTERISTICS					
Gain	Single-ended input to differential output		19		dB
	Input to output (single-ended)		13		dB
Input Voltage Range	AC-coupled		± 275		mV
Input Resistance	$R_{IZ} = 280\ \Omega$		50		Ω
	$R_{IZ} = 412\ \Omega$		75		Ω
	$R_{IZ} = 562\ \Omega$		100		Ω
	$R_{IZ} = 1.13\text{ k}\Omega$		200		Ω
	$R_{IZ} = \infty$		6		k Ω
Input Capacitance			13		pF
Output Impedance	Single-ended, either output		5		Ω
-3 dB Small Signal Bandwidth	$V_{OUT} = 0.2\text{ V p-p}$		130		MHz
Slew Rate			650		V/ μs
Input Voltage Noise	$R_S = 0\ \Omega$, HI or LO gain, $R_{IZ} = \infty$, $f = 5\text{ MHz}$		0.74		nV/ $\sqrt{\text{Hz}}$
Input Current Noise	$R_{IZ} = \infty$, HI or LO gain, $f = 5\text{ MHz}$		2.5		pA/ $\sqrt{\text{Hz}}$
Noise Figure	$f = 10\text{ MHz}$, LOP output				
Active Termination Match	$R_S = R_{IN} = 50\ \Omega$		3.7		dB
Unterminated	$R_S = 50\ \Omega$, $R_{IZ} = \infty$		2.5		dB
Harmonic Distortion at LOP1 or LOP2	$V_{OUT} = 0.5\text{ V p-p}$, single-ended, $f = 10\text{ MHz}$				
HD2			-56		dBc
HD3			-70		dBc
Output Short-Circuit Current	Pin LON, Pin LOP		165		mA
LNA AND VGA CHARACTERISTICS					
-3 dB Small Signal Bandwidth	$V_{OUT} = 0.2\text{ V p-p}$				
AD8331			120		MHz
AD8332, AD8334			100		MHz
-3 dB Large Signal Bandwidth	$V_{OUT} = 2\text{ V p-p}$				
AD8331			110		MHz
AD8332, AD8334			90		MHz
Slew Rate					
AD8331	LO gain		300		V/ μs
	HI gain		1200		V/ μs
AD8332, AD8334	LO gain		275		V/ μs
	HI gain		1100		V/ μs
Input Voltage Noise	$R_S = 0\ \Omega$, HI or LO gain, $R_{IZ} = \infty$, $f = 5\text{ MHz}$		0.82		nV/ $\sqrt{\text{Hz}}$
Noise Figure	$V_{GAIN} = 1.0\text{ V}$				
Active Termination Match	$R_S = R_{IN} = 50\ \Omega$, $f = 10\text{ MHz}$, measured		4.15		dB
	$R_S = R_{IN} = 200\ \Omega$, $f = 5\text{ MHz}$, simulated		2.0		dB
Unterminated	$R_S = 50\ \Omega$, $R_{IZ} = \infty$, $f = 10\text{ MHz}$, measured		2.5		dB
	$R_S = 200\ \Omega$, $R_{IZ} = \infty$, $f = 5\text{ MHz}$, simulated		1.0		dB
Output-Referred Noise					
AD8331	$V_{GAIN} = 0.5\text{ V}$, LO gain		48		nV/ $\sqrt{\text{Hz}}$
	$V_{GAIN} = 0.5\text{ V}$, HI gain		178		nV/ $\sqrt{\text{Hz}}$
AD8332, AD8334	$V_{GAIN} = 0.5\text{ V}$, LO gain		40		nV/ $\sqrt{\text{Hz}}$
	$V_{GAIN} = 0.5\text{ V}$, HI gain		150		nV/ $\sqrt{\text{Hz}}$
Output Impedance, Postamplifier	DC to 1 MHz		1		Ω

AD8331/AD8332/AD8334

Parameter	Test Conditions/Comments	Min	Typ	Max	Unit ¹
Output Signal Range, Postamplifier Differential	$R_L \geq 500 \Omega$, unclamped, either pin		$V_{CM} \pm 1.125$ 4.5		V V p-p
Output Offset Voltage AD8331	Differential, $V_{GAIN} = 0.5 V$	-50	± 5	+50	mV
	Common mode	-125	-25	+100	mV
AD8332, AD8334	Differential, $0.05 V \leq V_{GAIN} \leq 1.0 V$	-20	± 5	+20	mV
	Common mode	-125	-25	+100	mV
Output Short-Circuit Current			45		mA
Harmonic Distortion	$V_{GAIN} = 0.5 V, V_{OUT} = 1 V$ p-p, HI gain				
AD8331					
HD2	$f = 1 MHz$		-88		dBc
HD3			-85		dBc
HD2	$f = 10 MHz$		-68		dBc
HD3			-65		dBc
AD8332, AD8334					
HD2	$f = 1 MHz$		-82		dBc
HD3			-85		dBc
HD2	$f = 10 MHz$		-62		dBc
HD3			-66		dBc
Input 1 dB Compression Point	$V_{GAIN} = 0.25 V, V_{OUT} = 1 V$ p-p, $f = 1 MHz$ to $10 MHz$		1		dBm
Two-Tone Intermodulation Distortion (IMD3) AD8331	$V_{GAIN} = 0.72 V, V_{OUT} = 1 V$ p-p, $f = 1 MHz$		-80		dBc
	$V_{GAIN} = 0.5 V, V_{OUT} = 1 V$ p-p, $f = 10 MHz$		-72		dBc
AD8332, AD8334	$V_{GAIN} = 0.72 V, V_{OUT} = 1 V$ p-p, $f = 1 MHz$		-78		dBc
	$V_{GAIN} = 0.5 V, V_{OUT} = 1 V$ p-p, $f = 10 MHz$		-74		dBc
Output Third-Order Intercept AD8331	$V_{GAIN} = 0.5 V, V_{OUT} = 1 V$ p-p, $f = 1 MHz$		38		dBm
	$V_{GAIN} = 0.5 V, V_{OUT} = 1 V$ p-p, $f = 10 MHz$		33		dBm
AD8332, AD8334	$V_{GAIN} = 0.5 V, V_{OUT} = 1 V$ p-p, $f = 1 MHz$		35		dBm
	$V_{GAIN} = 0.5 V, V_{OUT} = 1 V$ p-p, $f = 10 MHz$		32		dBm
Channel-to-Channel Crosstalk (AD8332, AD8334)	$V_{GAIN} = 0.5 V, V_{OUT} = 1 V$ p-p, $f = 1 MHz$		-98		dB
Overload Recovery	$V_{GAIN} = 1.0 V, V_{IN} = 50 mV$ p-p/ $1 V$ p-p, $f = 10 MHz$		5		ns
Group Delay Variation	$5 MHz < f < 50 MHz$, full gain range		± 2		ns
ACCURACY					
Absolute Gain Error ²	$0.05 V < V_{GAIN} < 0.10 V$	-1	+0.5	+2	dB
	$0.10 V < V_{GAIN} < 0.95 V$	-1	± 0.3	+1	dB
	$0.95 V < V_{GAIN} < 1.0 V$	-2	-1	+1	dB
Gain Law Conformance ³	$0.1 V < V_{GAIN} < 0.95 V$		± 0.2		dB
Channel-to-Channel Gain Matching	$0.1 V < V_{GAIN} < 0.95 V$		± 0.1		dB
GAIN CONTROL INTERFACE (Pin GAIN)					
Gain Scaling Factor	$0.10 V < V_{GAIN} < 0.95 V$	48.5	50	51.5	dB/V
Gain Range	LO gain		-4.5 to +43.5		dB
	HI gain		7.5 to 55.5		dB
Input Voltage (V_{GAIN}) Range			0 to 1.0		V
Input Impedance			10		M Ω
Response Time	48 dB gain change to 90% full scale		500		ns
COMMON-MODE INTERFACE (PIN VCMx)					
Input Resistance ⁴	Current limited to $\pm 1 mA$		30		Ω
Output CM Offset Voltage	$V_{CM} = 2.5 V$	-125	-25	+100	mV
Voltage Range	$V_{OUT} = 2.0 V$ p-p		1.5 to 3.5		V

AD8331/AD8332/AD8334

Parameter	Test Conditions/Comments	Min	Typ	Max	Unit ¹
ENABLE INTERFACE (PIN ENB, PIN ENBL, PIN ENBV) Logic Level to Enable Power Logic Level to Disable Power Input Resistance Power-Up Response Time	Pin ENB Pin ENBL Pin ENBV $V_{INH} = 30 \text{ mV p-p}$ $V_{INH} = 150 \text{ mV p-p}$	2.25 0	25 40 70	5 1.0	V V k Ω k Ω k Ω μs ms
HILO GAIN RANGE INTERFACE (PIN HILO) Logic Level to Select HI Gain Range Logic Level to Select LO Gain Range Input Resistance		2.25 0	50	5 1.0	V V k Ω
OUTPUT CLAMP INTERFACE (PIN RCLMP; HI OR LO GAIN) Accuracy HILO = LO HILO = HI	$R_{CLMP} = 2.74 \text{ k}\Omega, V_{OUT} = 1 \text{ V p-p (clamped)}$ $R_{CLMP} = 2.21 \text{ k}\Omega, V_{OUT} = 1 \text{ V p-p (clamped)}$		± 50 ± 75		mV mV
MODE INTERFACE (PIN MODE) Logic Level for Positive Gain Slope Logic Level for Negative Gain Slope Input Resistance		0 2.25	200	1.0 5	V V k Ω
POWER SUPPLY (PIN VPS1, PIN VPS2, PIN VPSV, PIN VPSL, PIN VPOS) Supply Voltage Quiescent Current per Channel AD8331 AD8332 AD8334 Power Dissipation per Channel AD8331 AD8332, AD8334 Power-Down Current AD8331 AD8332 AD8334 LNA Current AD8331 (ENBL) AD8332, AD8334 (ENBL) VGA Current AD8331 (ENBV) AD8332, AD8334 (ENBV) PSRR	No signal VGA and LNA disabled Each channel Each channel $V_{GAIN} = 0 \text{ V}, f = 100 \text{ kHz}$	4.5 20 22 24	5.0 25 27.5 29.5 125 138 240 300 600	5.5 32 34	V mA mA mA mW mW μA μA μA mA mA mA mA dB

¹ All dBm values are referred to 50 Ω .

² The absolute gain refers to the theoretical gain expression in Equation 1.

³ Best-fit to linear-in-dB curve.

⁴ The current is limited to $\pm 1 \text{ mA}$ typical.

ABSOLUTE MAXIMUM RATINGS

Table 2.

Parameter	Rating
Voltage	
Supply Voltage (VPSn, VPSV, VPSL, VPOS)	5.5 V
Input Voltage (INHx)	$V_S + 200 \text{ mV}$
ENB, ENBL, ENBV, HILO Voltage	$V_S + 200 \text{ mV}$
GAIN Voltage	2.5 V
Power Dissipation	
RU Package ¹ (AD8332)	0.96 W
CP-32 Package (AD8332)	1.97 W
RQ Package ¹ (AD8331)	0.78 W
CP-64 Package (AD8334)	0.91 W
Temperature	
Operating Temperature Range	-40°C to +85°C
Storage Temperature Range	-65°C to +150°C
Lead Temperature (Soldering 60 sec)	300°C
θ_{JA}	
RU Package ¹ (AD8332)	68°C/W
CP-32 Package ² (AD8332)	33°C/W
RQ Package ¹ (AD8331)	83°C/W
CP-64 Package ³ (AD8334)	24.2°C/W

¹ 4-layer JEDEC board (2S2P).² Exposed pad soldered to board, nine thermal vias in pad—JEDEC, 4-layer board J-STD-51-9.³ Exposed pad soldered to board, 25 thermal vias in pad—JEDEC, 4-layer board J-STD-51-9.

Stresses above those listed under Absolute Maximum Ratings may cause permanent damage to the device. This is a stress rating only; functional operation of the device at these or any other conditions above those indicated in the operational section of this specification is not implied. Exposure to absolute maximum rating conditions for extended periods may affect device reliability.

ESD CAUTION



ESD (electrostatic discharge) sensitive device.

Charged devices and circuit boards can discharge without detection. Although this product features patented or proprietary protection circuitry, damage may occur on devices subjected to high energy ESD. Therefore, proper ESD precautions should be taken to avoid performance degradation or loss of functionality.

PIN CONFIGURATIONS AND FUNCTION DESCRIPTIONS

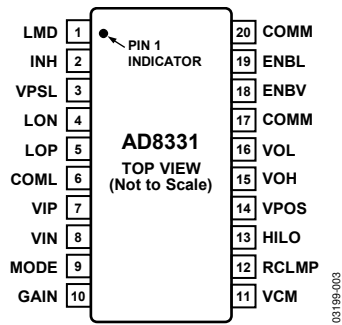

Figure 3. 20-Lead QSOP Pin Configuration (AD8331)

Table 3. 20-Lead QSOP Pin Function Description (AD8331)

Pin No.	Mnemonic	Description
1	LMD	LNA Midsupply Bypass Pin; Connect a Capacitor for Midsupply HF Bypass
2	INH	LNA Input
3	VPSL	LNA 5 V Supply
4	LON	LNA Inverting Output
5	LOP	LNA Noninverting Output
6	COML	LNA Ground
7	VIP	VGA Noninverting Input
8	VIN	VGA Inverting Input
9	MODE	Gain Slope Logic Input
10	GAIN	Gain Control Voltage
11	VCM	Common-Mode Voltage
12	RCLMP	Output Clamping Level
13	HILO	Gain Range Select (HI or LO)
14	VPOS	VGA 5 V Supply
15	VOH	Noninverting VGA Output
16	VOL	Inverting VGA Output
17	COMM	VGA Ground
18	ENBV	VGA Enable
19	ENBL	LNA Enable
20	COMM	VGA Ground

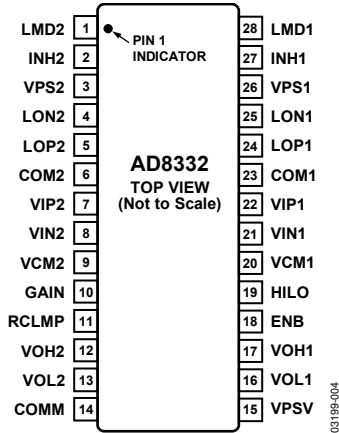
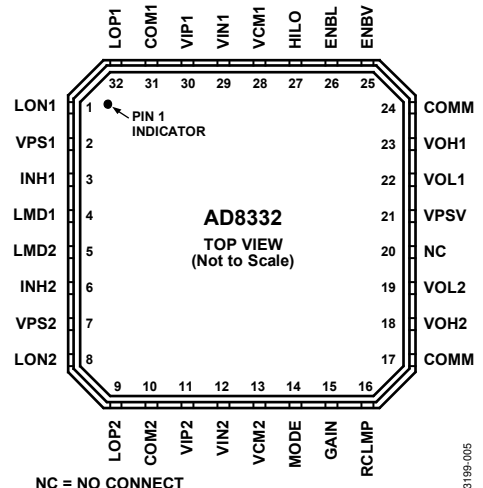

Figure 4. 28-Lead TSSOP Pin Configuration (AD8332)



NC = NO CONNECT

Figure 5. 32-Lead LFCSP Pin Configuration (AD8332)

Table 4. 28-Lead TSSOP Pin Function Description (AD8332)

Pin No.	Mnemonic	Description
1	LMD2	CH 2 LNA Midsupply Pin; Connect a Capacitor for Midsupply HF Bypass
2	INH2	CH2 LNA Input
3	VPS2	CH2 Supply LNA 5 V
4	LON2	CH2 LNA Inverting Output
5	LOP2	CH2 LNA Noninverting Output
6	COM2	CH2 LNA Ground
7	VIP2	CH2 VGA Noninverting Input
8	VIN2	CH2 VGA Inverting Input
9	VCM2	CH2 Common-Mode Voltage
10	GAIN	Gain Control Voltage
11	RCLMP	Output Clamping Resistor
12	VOH2	CH2 Noninverting VGA Output
13	VOL2	CH2 Inverting VGA Output
14	COMM	VGA Ground (Both Channels)
15	VPSV	VGA Supply 5 V (Both Channels)
16	VOL1	CH1 Inverting VGA Output
17	VOH1	CH1 Noninverting VGA Output
18	ENB	Enable—VGA/LNA
19	HILO	VGA Gain Range Select (HI or LO)
20	VCM1	CH1 Common-Mode Voltage
21	VIN1	CH1 VGA Inverting Input
22	VIP1	CH1 VGA Noninverting Input
23	COM1	CH1 LNA Ground
24	LOP1	CH1 LNA Noninverting Output
25	LON1	CH1 LNA Inverting Output
26	VPS1	CH1 LNA Supply 5 V
27	INH1	CH1 LNA Input
28	LMD1	CH 1 LNA Midsupply Pin; Connect a Capacitor for Midsupply HF Bypass

Table 5. 32-Lead LFCSP Pin Function Description (AD8332)

Pin No.	Mnemonic	Description
1	LON1	CH1 LNA Inverting Output
2	VPS1	CH1 LNA Supply 5 V
3	INH1	CH1 LNA Input
4	LMD1	CH 1 LNA Midsupply Pin; Connect a Capacitor for Midsupply HF Bypass
5	LMD2	CH 2 LNA Midsupply Pin; Connect a Capacitor for Midsupply HF Bypass
6	INH2	CH2 LNA Input
7	VPS2	CH2 LNA Supply 5 V
8	LON2	CH2 LNA Inverting Output
9	LOP2	CH2 LNA Noninverting Output
10	COM2	CH2 LNA Ground
11	VIP2	CH2 VGA Noninverting Input
12	VIN2	CH2 VGA Inverting Input
13	VCM2	CH2 Common-Mode Voltage
14	MODE	Gain Slope Logic Input
15	GAIN	Gain Control Voltage
16	RCLMP	Output Clamping Level Input
17	COMM	VGA Ground
18	VOH2	CH2 Noninverting VGA Output
19	VOL2	CH2 Inverting VGA Output
20	NC	No Connect
21	VPSV	VGA Supply 5 V
22	VOL1	CH1 Inverting VGA Output
23	VOH1	CH1 Noninverting VGA Output
24	COMM	VGA Ground
25	ENBV	VGA Enable
26	ENBL	LNA Enable
27	HILO	VGA Gain Range Select (HI or LO)
28	VCM1	CH1 Common-Mode Voltage
29	VIN1	CH1 VGA Inverting Input
30	VIP1	CH1 VGA Noninverting Input
31	COM1	CH1 LNA Ground
32	LOP1	CH1 LNA Noninverting Output

AD8331/AD8332/AD8334

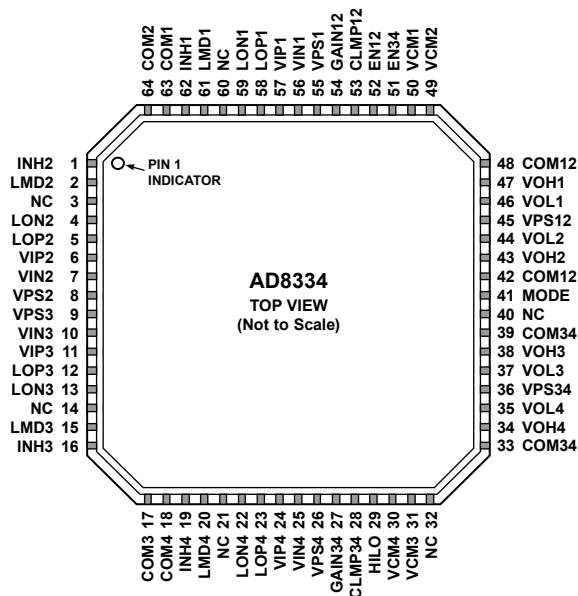

- NOTES**
1. THE EXPOSED PADDLE MUST BE SOLDERED TO THE PCB GROUND TO ENSURE PROPER HEAT DISSIPATION, NOISE, AND MECHANICAL STRENGTH BENEFITS.
 2. NC = NO CONNECT.

03199-006

Figure 6. 64-Lead LFCSP Pin Configuration (AD8334)

Table 6. 64-Lead LFCSP Pin Function Description (AD8334)

Pin No.	Mnemonic	Description
1	INH2	CH2 LNA Input.
2	LMD2	CH 2 LNA Midsupply Pin; Connect a Capacitor for Midsupply HF Bypass.
3	NC	Not Connected.
4	LON2	CH2 LNA Feedback Output (for R_{IZ}).
5	LOP2	CH2 LNA Output.
6	VIP2	CH2 VGA Positive Input.
7	VIN2	CH2 VGA Negative Input.
8	VPS2	CH2 LNA Supply 5 V.
9	VPS3	CH3 LNA Supply 5 V.
10	VIN3	CH3 VGA Negative Input.
11	VIP3	CH3 VGA Positive Input.
12	LOP3	CH3 LNA Positive Output.
13	LON3	CH3 LNA Feedback Output (for R_{IZ}).
14	NC	Not Connected.
15	LMD3	CH 3 LNA Midsupply Pin; Connect a Capacitor for Midsupply HF Bypass.
16	INH3	CH3 LNA Input.
17	COM3	CH3 LNA Ground.
18	COM4	CH4 LNA Ground.
19	INH4	CH4 LNA Input.
20	LMD4	CH 4 LNA Midsupply Pin; Connect a Capacitor for Midsupply HF Bypass.
21	NC	Not Connected.
22	LON4	CH4 LNA Feedback Output (for R_{IZ}).
23	LOP4	CH4 LNA Positive Output.
24	VIP4	CH4 VGA Positive Input.
25	VIN4	CH4 VGA Negative Input.
26	VPS4	CH4 LNA Supply 5 V.

Pin No.	Mnemonic	Description
27	GAIN34	Gain Control Voltage for CH3 and CH4.
28	CLMP34	Output Clamping Level Input for CH3 and CH4.
29	HILO	Gain Select for Postamp 0 dB or 12 dB.
30	VCM4	CH4 Common-Mode Voltage—AC Bypass.
31	VCM3	CH3 Common-Mode Voltage—AC Bypass.
32	NC	No Connect.
33	COM34	VGA Ground CH3 and CH4.
34	VOH4	CH4 Positive VGA Output.
35	VOL4	CH4 Negative VGA Output.
36	VPS34	VGA Supply 5 V CH3 and CH4.
37	VOL3	CH3 Negative VGA Output.
38	VOH3	CH3 Positive VGA Output.
39	COM34	VGA Ground CH3 and CH4.
40	NC	No Connect.
41	MODE	Gain Control Slope, Logic Input, 0 = Positive.
42	COM12	VGA Ground CH1 and CH2.
43	VOH2	CH2 Positive VGA Output.
44	VOL2	CH2 Negative VGA Output.
45	VPS12	CH2 VGA Supply 5 V CH1 and CH2.
46	VOL1	CH1 Negative VGA Output.
47	VOH1	CH1 Positive VGA Output.
48	COM12	VGA Ground CH1 and CH2.
49	VCM2	CH2 Common-Mode Voltage—AC Bypass.
50	VCM1	CH1 Common-Mode Voltage—AC Bypass.
51	EN34	Shared LNA/VGA Enable CH3 and CH4.
52	EN12	Shared LNA/VGA Enable CH1 and CH2.
53	CLMP12	Output Clamping Level Input CH1 and CH2.
54	GAIN12	Gain Control Voltage CH1 and CH2.
55	VPS1	CH1 LNA Supply 5 V.
56	VIN1	CH1 VGA Negative Input.
57	VIP1	CH1 VGA Positive Input.
58	LOP1	CH1 LNA Positive Output.
59	LON1	CH1 LNA Feedback Output (for R_{iz}).
60	NC	Not Connected.
61	LMD1	CH 1 LNA Midsupply Pin; Connect a Capacitor for Midsupply HF Bypass.
62	INH1	CH1 LNA Input.
63	COM1	CH1 LNA Ground.
64	COM2	CH2 LNA Ground.
	EPAD	The exposed paddle must be soldered to the PCB ground to ensure proper heat dissipation, noise, and mechanical strength benefits.

TYPICAL PERFORMANCE CHARACTERISTICS

$T_A = 25^\circ\text{C}$, $V_S = 5\text{ V}$, $R_L = 500\ \Omega$, $R_S = R_{IN} = 50\ \Omega$, $R_{IZ} = 280\ \Omega$, $C_{SH} = 22\ \text{pF}$, $f = 10\ \text{MHz}$, $R_{CLMP} = \infty$, $C_L = 1\ \text{pF}$, VCM pin floating, $-4.5\ \text{dB}$ to $+43.5\ \text{dB}$ gain (HILO = LO), and differential output voltage, unless otherwise specified.

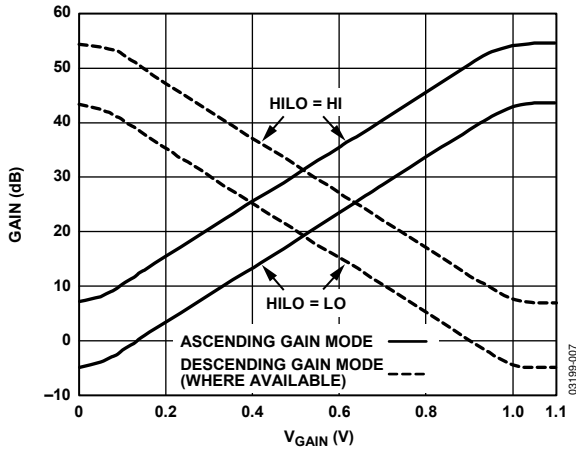

Figure 7. Gain vs. V_{GAIN} and MODE (MODE Available on RU Package)

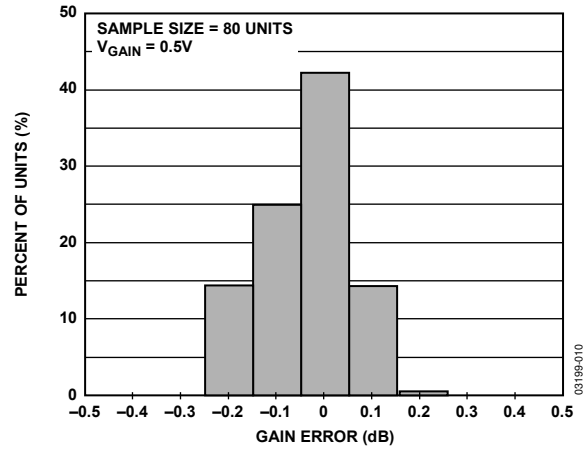

Figure 10. Gain Error Histogram

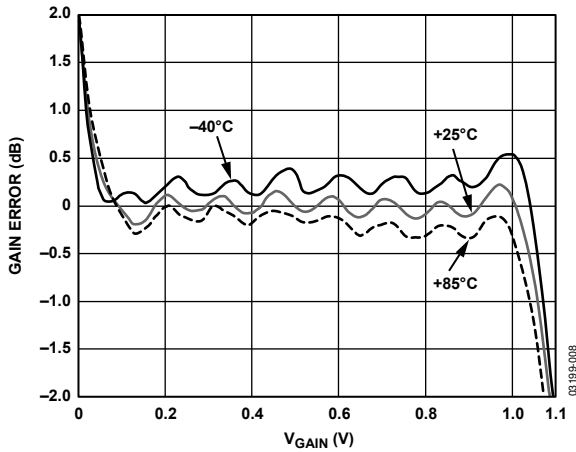

Figure 8. Absolute Gain Error vs. V_{GAIN} at Three Temperatures

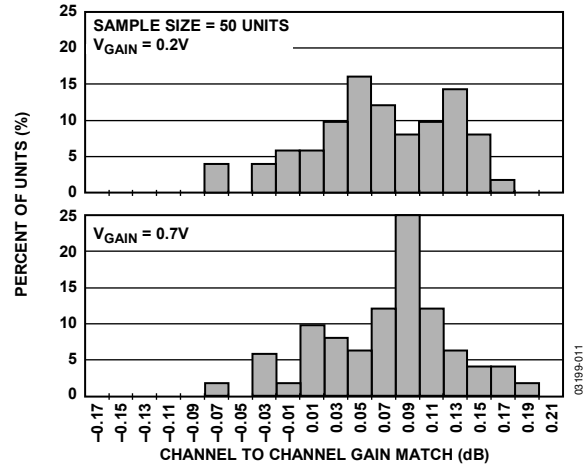

Figure 11. Gain Match Histogram for $V_{GAIN} = 0.2\text{ V}$ and 0.7 V

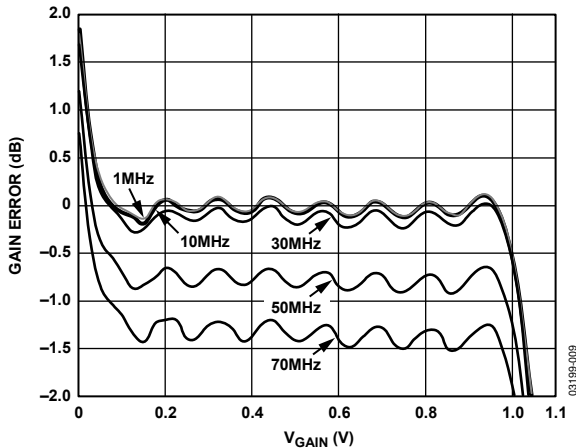

Figure 9. Absolute Gain Error vs. V_{GAIN} at Various Frequencies

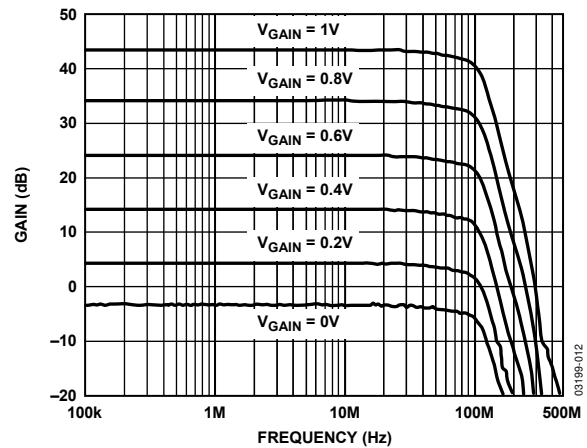

Figure 12. Frequency Response for Various Values of V_{GAIN}

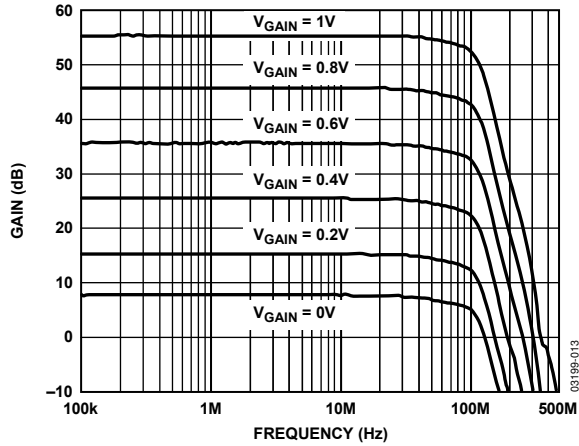

Figure 13. Frequency Response for Various Values of V_{GAIN} , HILO = HI

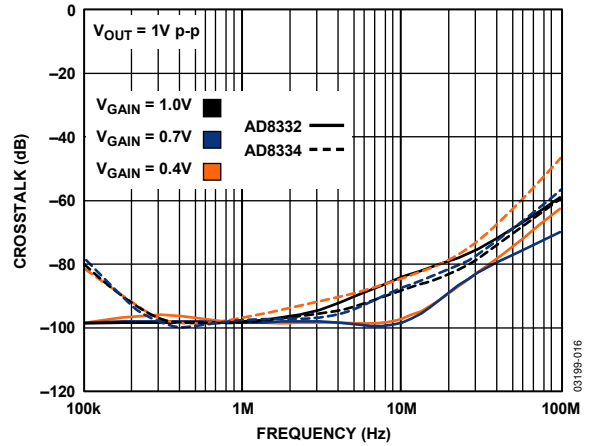

Figure 16. Channel-to-Channel Crosstalk. Frequency for Various Values of V_{GAIN}

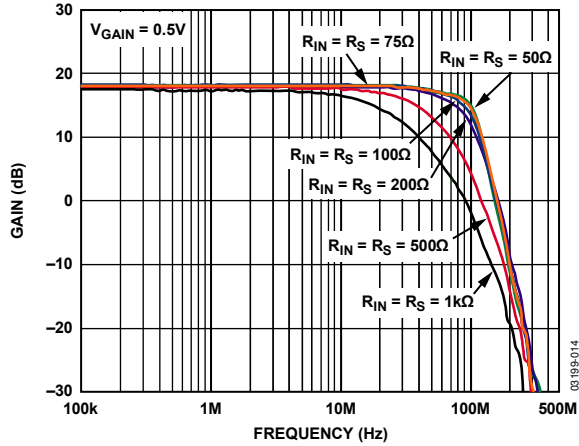

Figure 14. Frequency Response for Various Matched Source Impedances

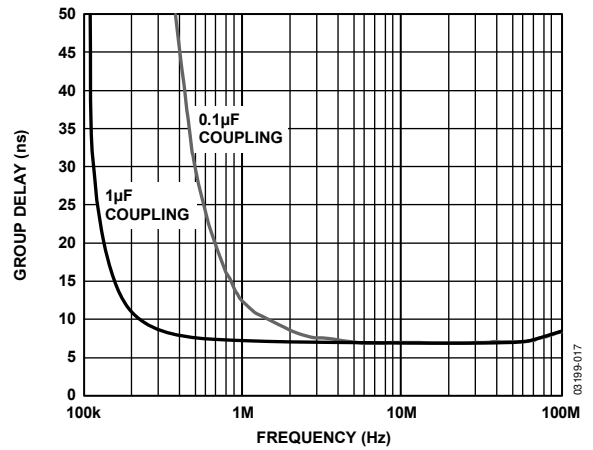

Figure 17. Group Delay vs. Frequency for Two Values of AC Coupling

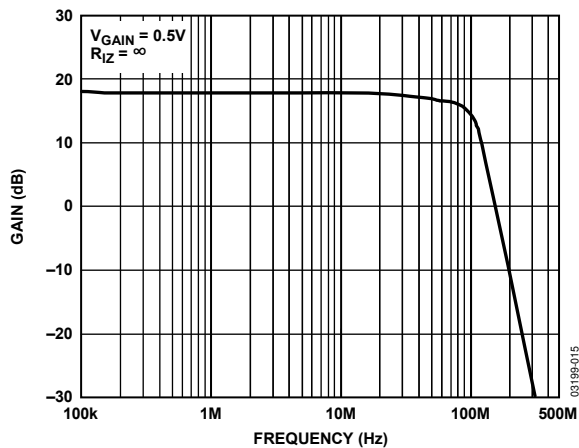

Figure 15. Frequency Response, Underterminated LNA, $R_S = 50\Omega$

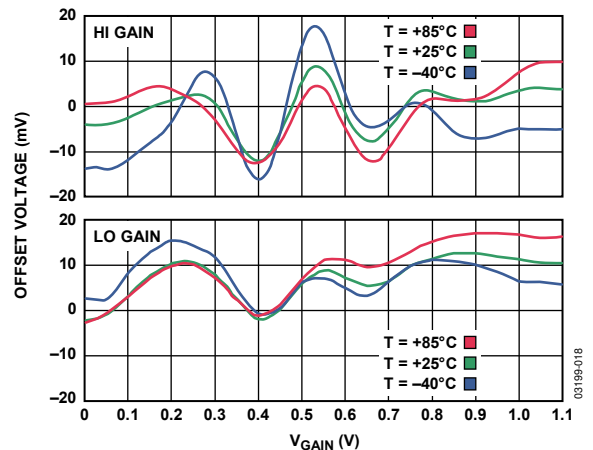

Figure 18. Representative Differential Output Offset Voltage vs. V_{GAIN} at Three Temperatures

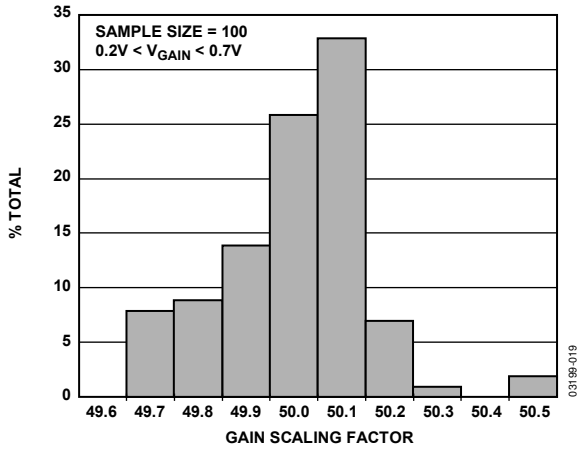

Figure 19. Gain Scaling Factor Histogram

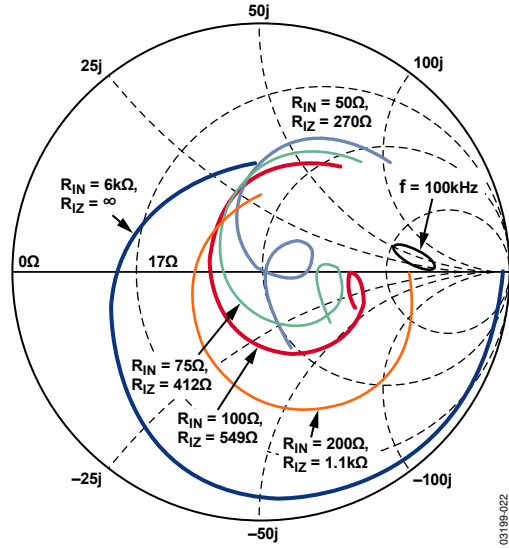

Figure 22. Smith Chart, S11 vs. Frequency, 0.1 MHz to 200 MHz for Various Values of R_{IZ}

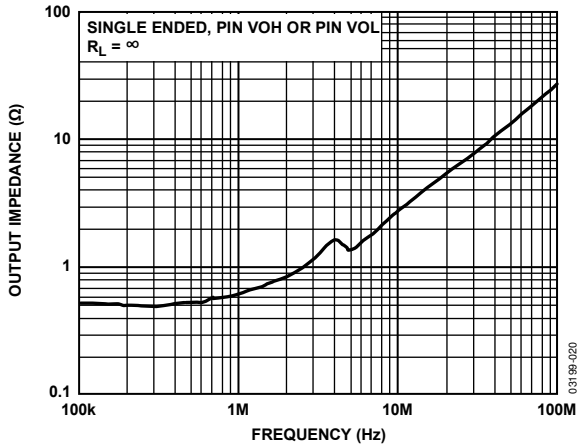

Figure 20. Output Impedance vs. Frequency

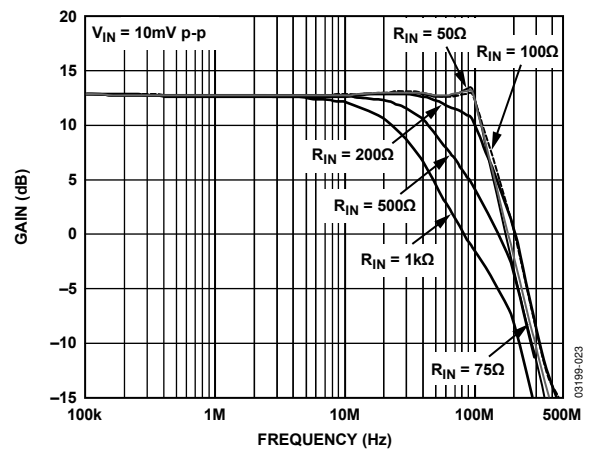

Figure 23. LNA Frequency Response, Single-Ended, for Various Values of R_{IN}

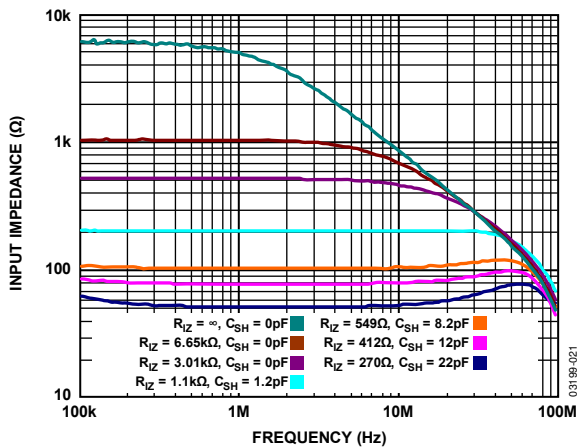

Figure 21. LNA Input Impedance vs. Frequency for Various Values of R_{IZ} and C_{SH}

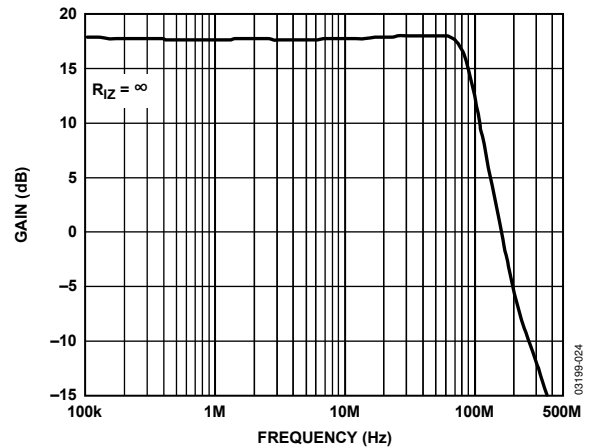

Figure 24. Frequency Response for Unterminated LNA, Single-Ended

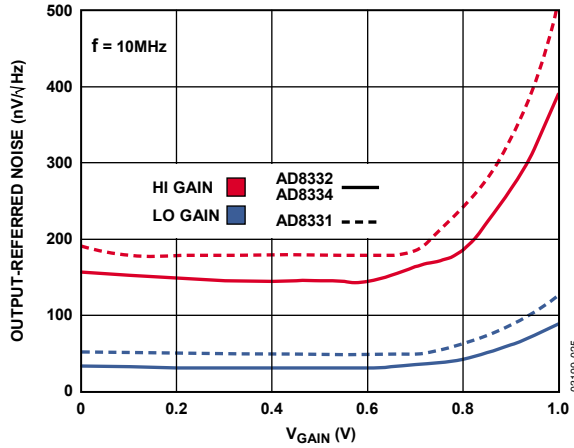

Figure 25. Output-Referred Noise vs. V_{GAIN}

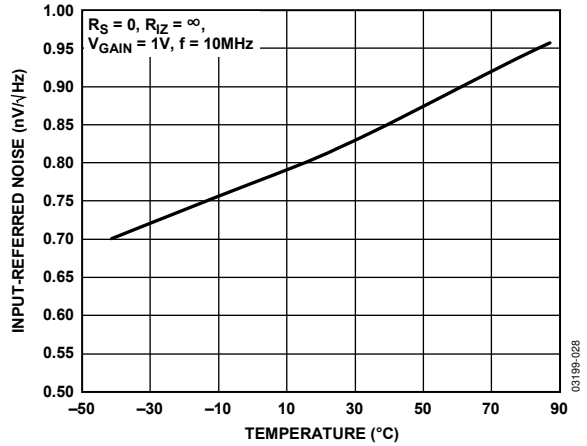

Figure 28. Short-Circuit, Input-Referred Noise vs. Temperature

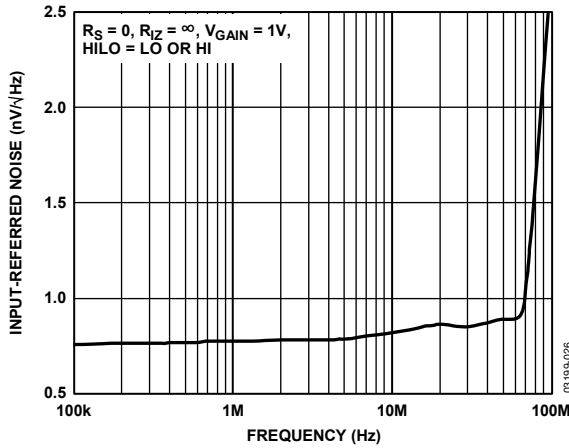

Figure 26. Short-Circuit, Input-Referred Noise vs. Frequency

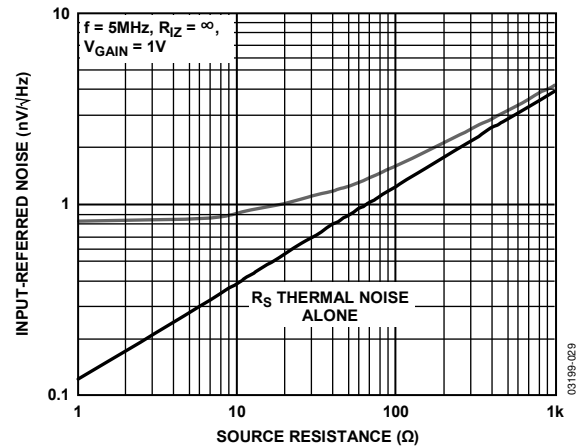

Figure 29. Input-Referred Noise vs. R_S

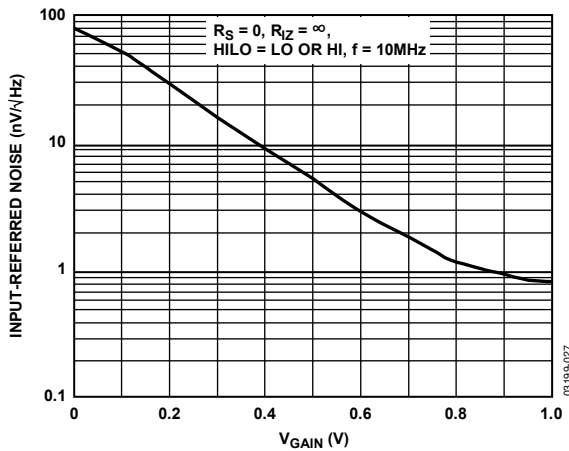

Figure 27. Short-Circuit, Input-Referred Noise vs. V_{GAIN}

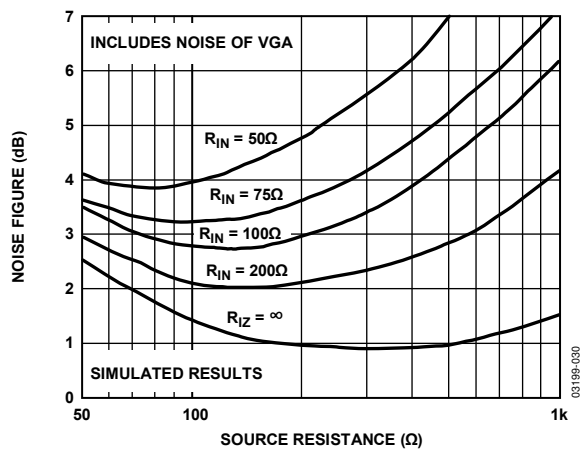

Figure 30. Noise Figure vs. R_S for Various Values of R_{IN}

AD8331/AD8332/AD8334

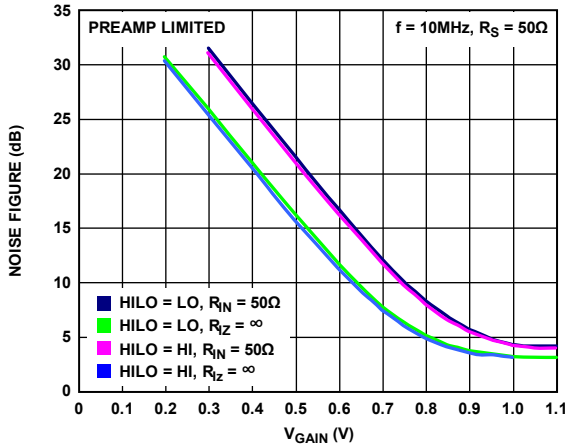

Figure 31. Noise Figure vs. V_{GAIN}

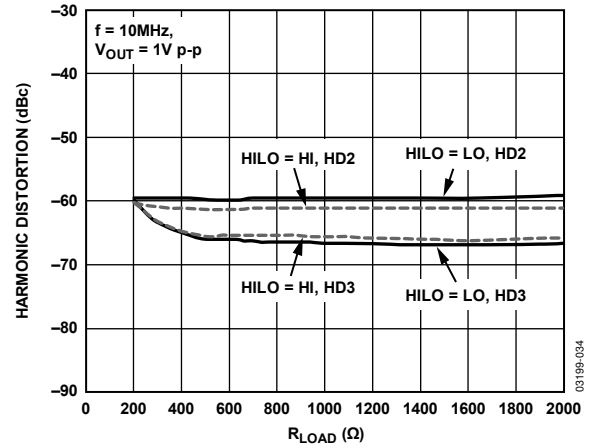

Figure 34. Harmonic Distortion vs. R_{LOAD}

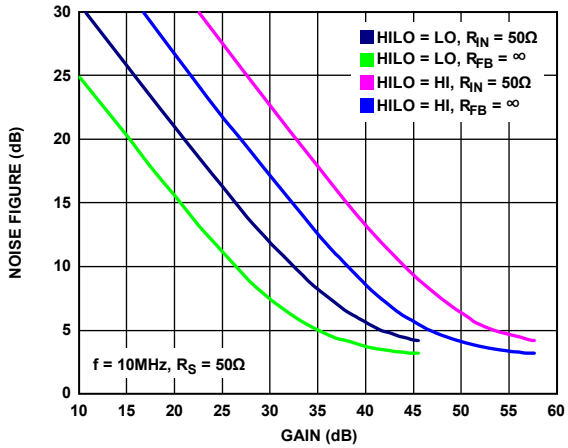

Figure 32. Noise Figure vs. Gain

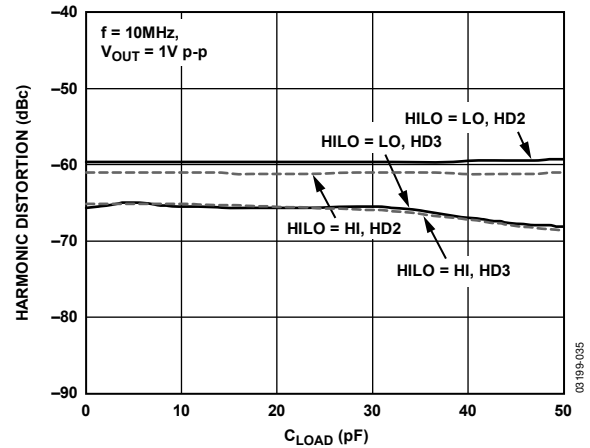

Figure 35. Harmonic Distortion vs. C_{LOAD}

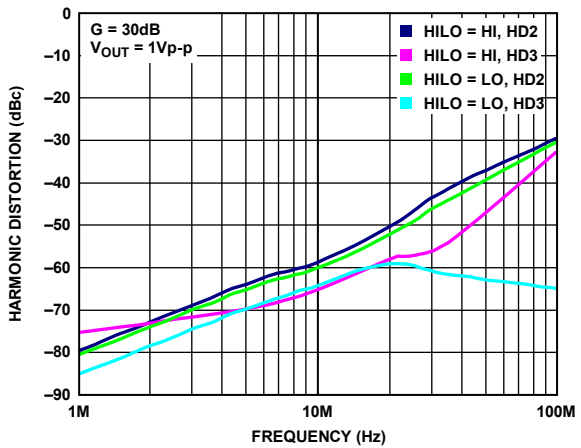

Figure 33. Harmonic Distortion vs. Frequency

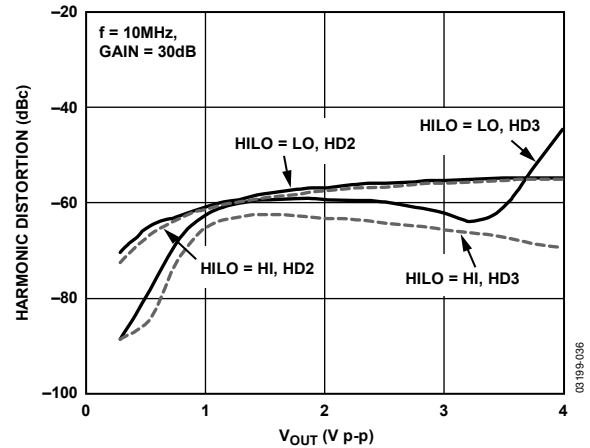

Figure 36. Harmonic Distortion vs. Differential Output Voltage

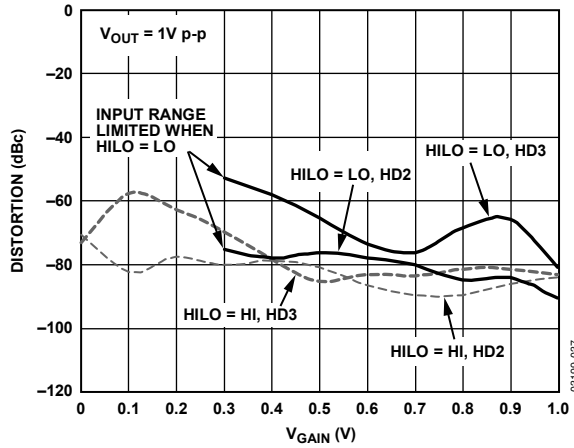

Figure 37. Harmonic Distortion vs. V_{GAIN} , $f = 1 \text{ MHz}$

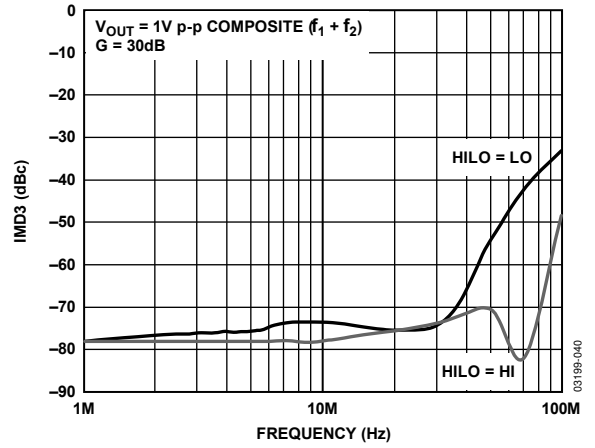

Figure 40. IMD3 vs. Frequency

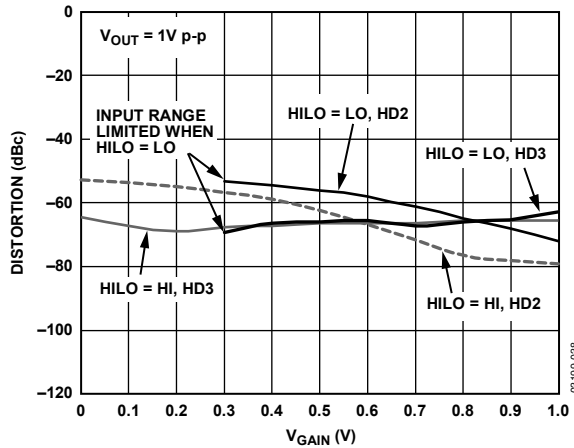

Figure 38. Harmonic Distortion vs. V_{GAIN} , $f = 10 \text{ MHz}$

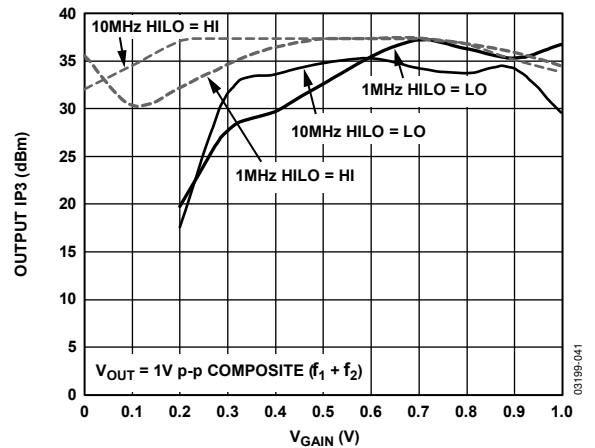

Figure 41. Output Third-Order Intercept (IP3) vs. V_{GAIN}

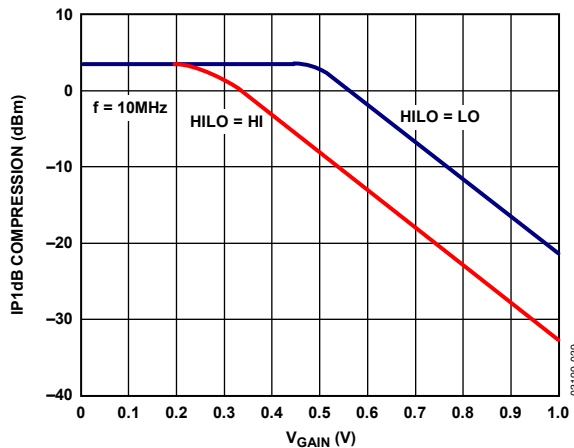

Figure 39. IP1dB Compression vs. V_{GAIN}

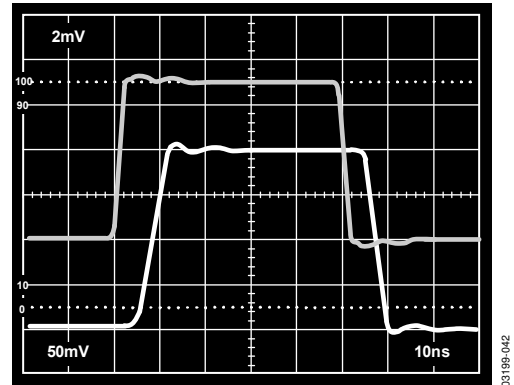

Figure 42. Small Signal Pulse Response, $G = 30 \text{ dB}$, Top: Input, Bottom: Output Voltage, HILO = HI or LO

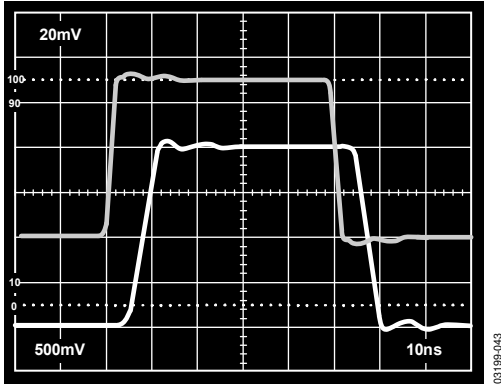

Figure 43. Large Signal Pulse Response, $G = 30$ dB, HILO = HI or LO, Top: Input, Bottom: Output Voltage

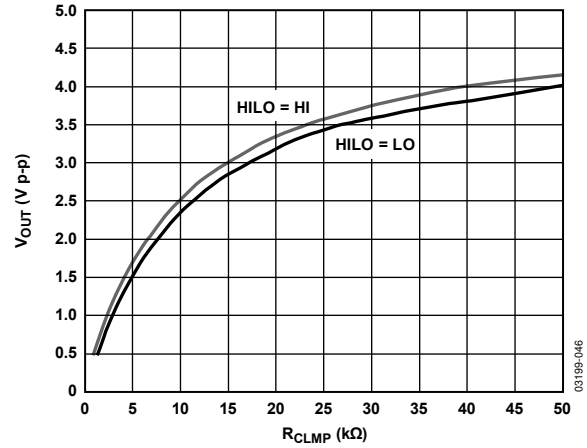

Figure 46. Clamp Level vs. R_{CLMP}

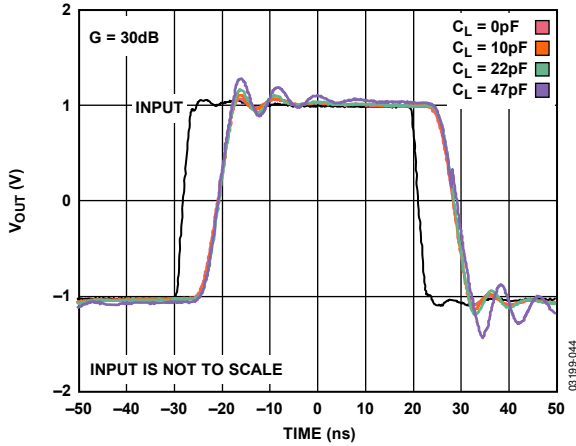

Figure 44. Large Signal Pulse Response for Various Capacitive Loads, $C_L = 0$ pF, 10 pF, 20 pF, 50 pF

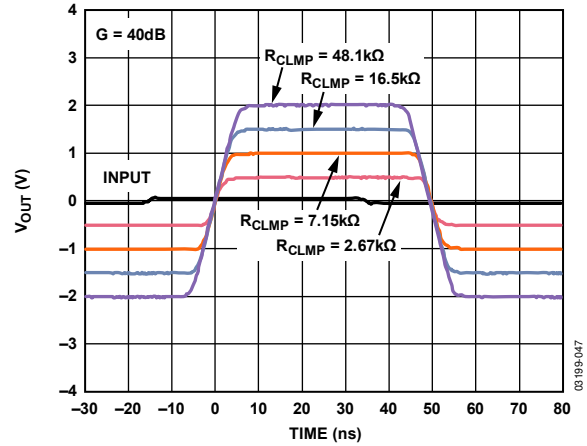

Figure 47. Clamp Level Pulse Response for Four Values of R_{CLMP}

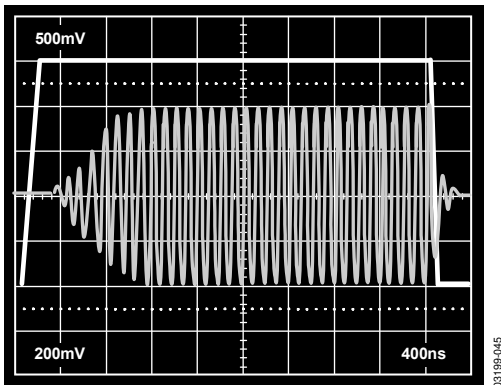

Figure 45. Pin GAIN Transient Response, Top: V_{GAIN} , Bottom: Output Voltage

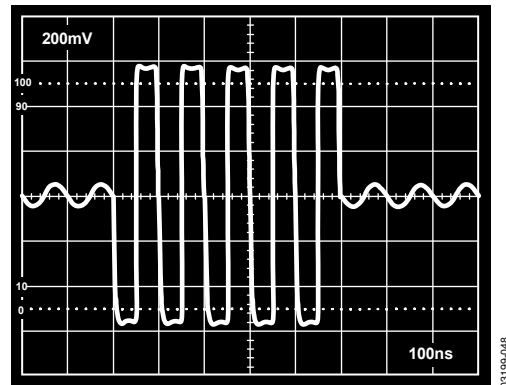

Figure 48. LNA Overdrive Recovery, $V_{INH} = 0.05$ V p-p to 1 V p-p Burst, $V_{GAIN} = 0.27$ V VGA Output Shown

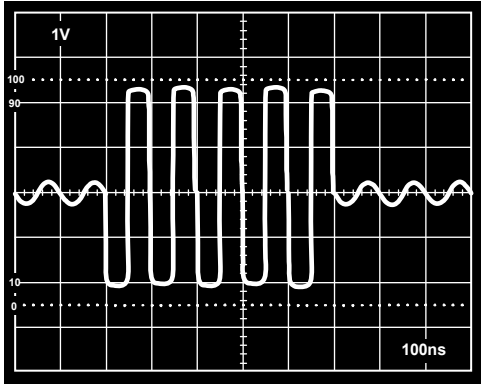

Figure 49. VGA Overdrive Recovery, V_{INH} 4 mV p-p to 70 mV p-p Burst, $V_{GAIN} = 1$ V VGA Output Shown Attenuated by 24 dB

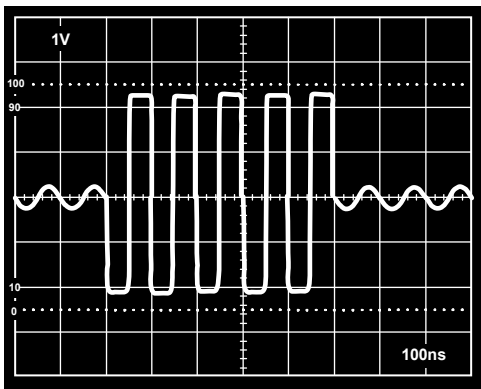

Figure 50. VGA Overdrive Recovery, V_{INH} 4 mV p-p to 275 mV p-p Burst, $V_{GAIN} = 1$ V VGA Output Shown Attenuated by 24 dB

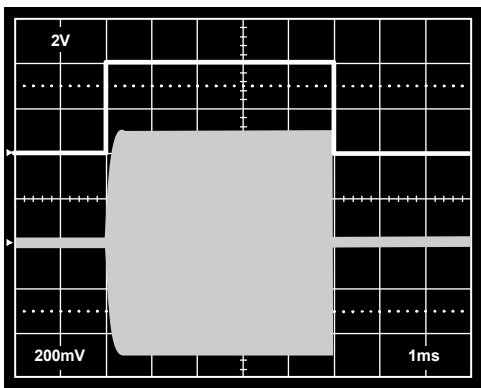

Figure 51. Enable Response, Top: V_{ENB} , Bottom: V_{OUT} , $V_{INH} = 30$ mV p-p

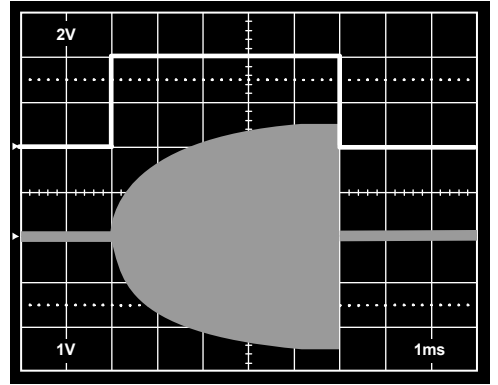

Figure 52. Enable Response, Large Signal, Top: V_{ENB} , Bottom: V_{OUT} , $V_{INH} = 150$ mV p-p

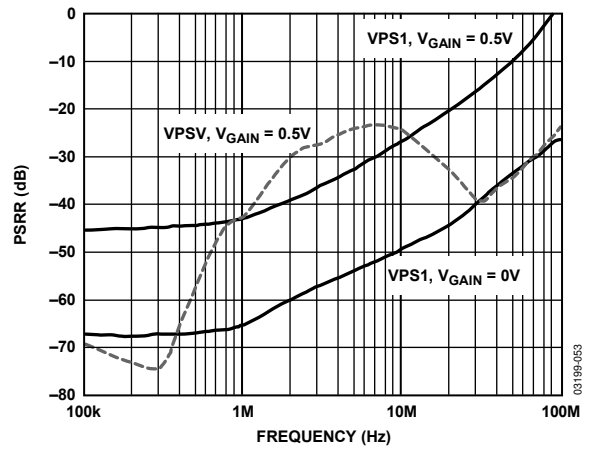

Figure 53. PSRR vs. Frequency (No Bypass Capacitor)

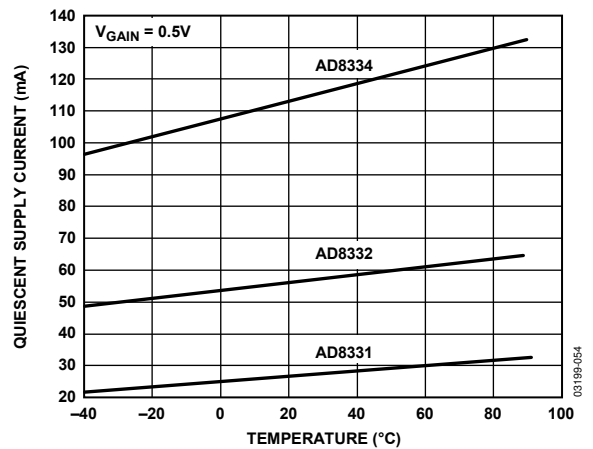

Figure 54. Quiescent Supply Current vs. Temperature

TEST CIRCUITS

MEASUREMENT CONSIDERATIONS

Figure 55 through Figure 68 show typical measurement configurations and proper interface values for measurements with 50 Ω conditions.

Short-circuit input noise measurements are made as shown in Figure 62. The input-referred noise level is determined by

dividing the output noise by the numerical gain between Point A and Point B and accounting for the noise floor of the spectrum analyzer. The gain should be measured at each frequency of interest and with low signal levels because a 50 Ω load is driven directly. The generator is removed when noise measurements are made.

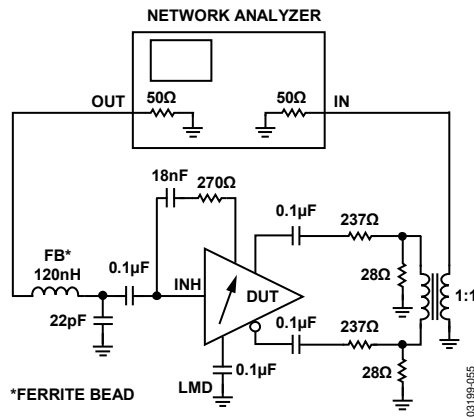

Figure 55. Test Circuit—Gain and Bandwidth Measurements

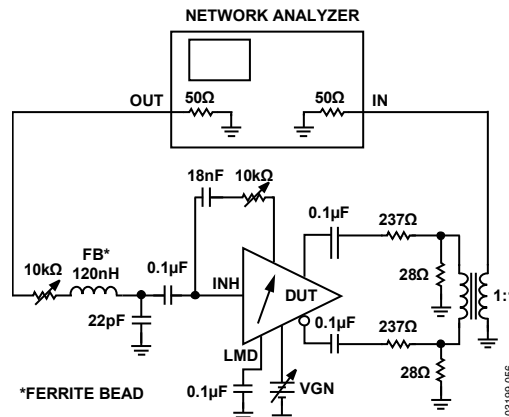

Figure 56. Test Circuit—Frequency Response for Various Matched Source Impedances

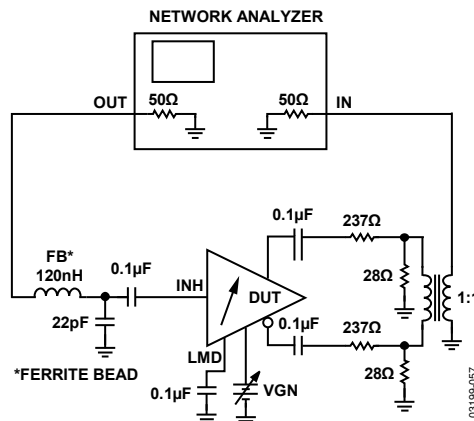

Figure 57. Test Circuit—Frequency Response for Underterminated LNA, $R_s = 50\ \Omega$

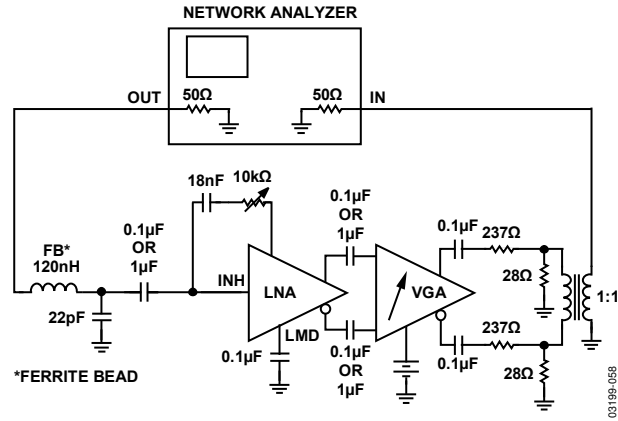

Figure 58. Test Circuit—Group Delay vs. Frequency for Two Values of AC Coupling

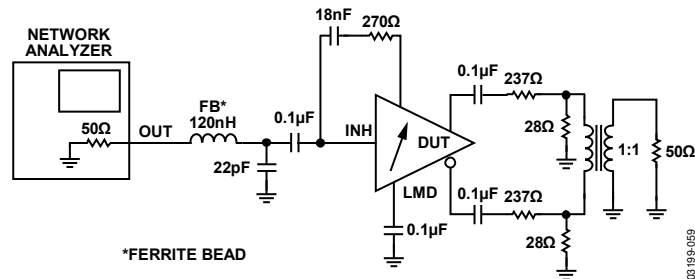

Figure 59. Test Circuit—LNA Input Impedance vs. Frequency in Standard and Smith Chart (S11) Formats

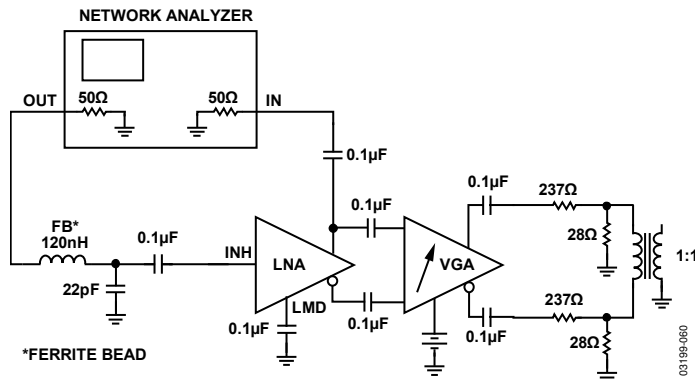

Figure 60. Test Circuit—Frequency Response for Underterminated LNA, Single-Ended

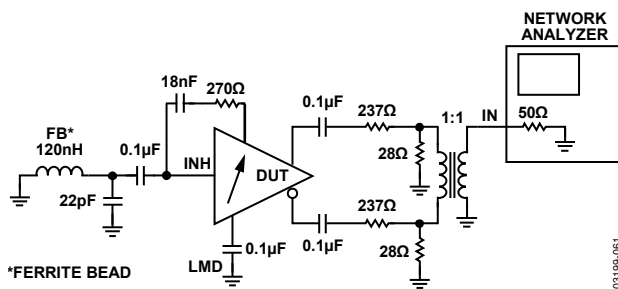

Figure 61. Test Circuit—Short-Circuit, Input-Referred Noise

AD8331/AD8332/AD8334

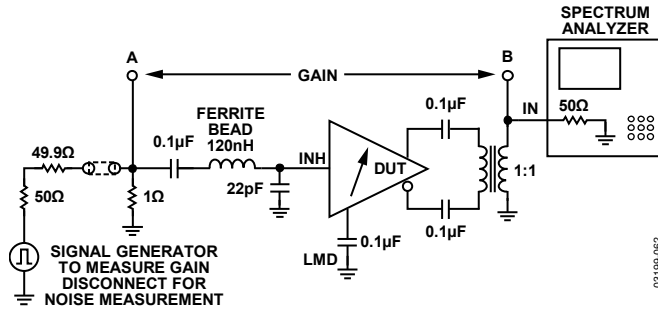

Figure 62. Test Circuit—Noise Figure

03199-062

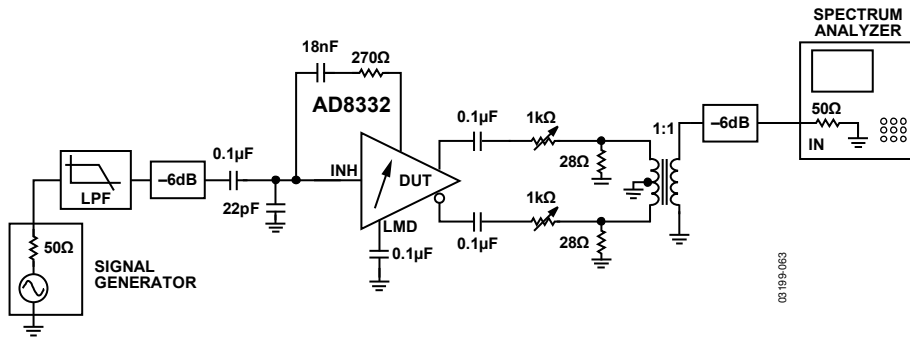

Figure 63. Test Circuit—Harmonic Distortion vs. Load Resistance

03199-063

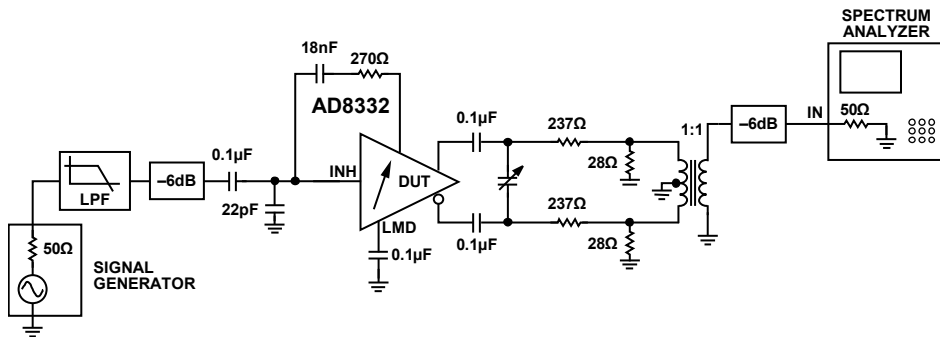
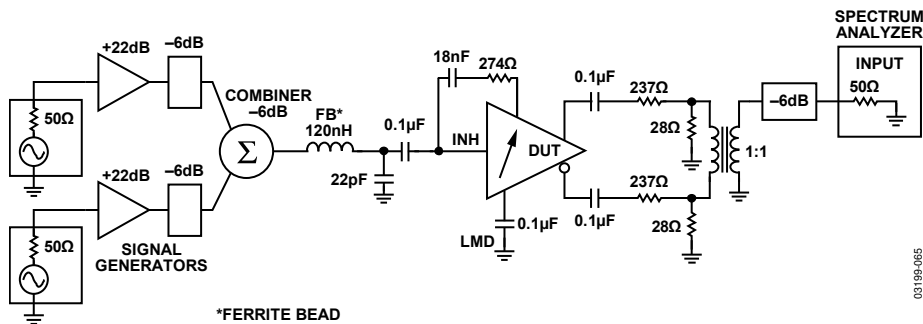

Figure 64. Test Circuit—Harmonic Distortion vs. Load Capacitance

03199-114



*FERRITE BEAD

Figure 65. Test Circuit—IMD3 vs. Frequency

03199-065

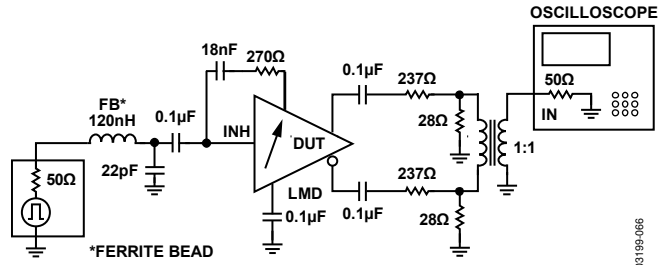

Figure 66. Test Circuit—Pulse Response Measurements

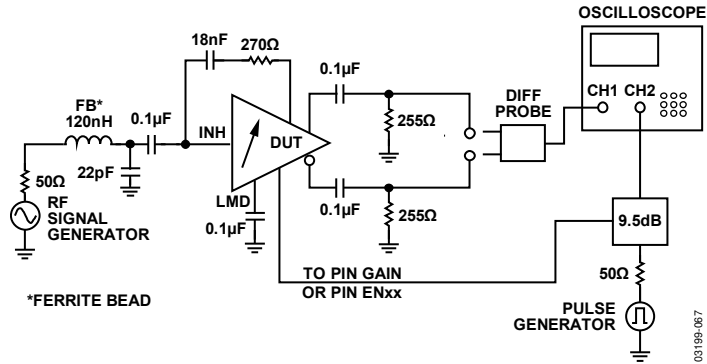

Figure 67. Test Circuit—Gain and Enable Transient Response

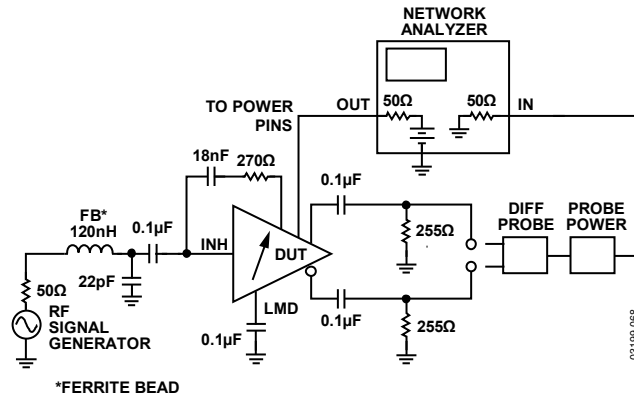

Figure 68. Test Circuit—PSRR vs. Frequency

THEORY OF OPERATION

OVERVIEW

The AD8331/AD8332/AD8334 operate in the same way. Figure 69, Figure 70, and Figure 71 are functional block diagrams of the three devices

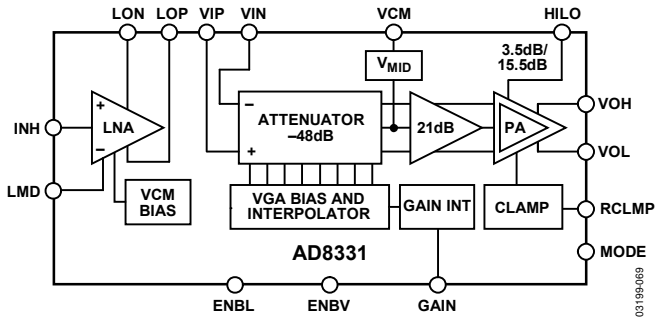

Figure 69. AD8331 Functional Block Diagram

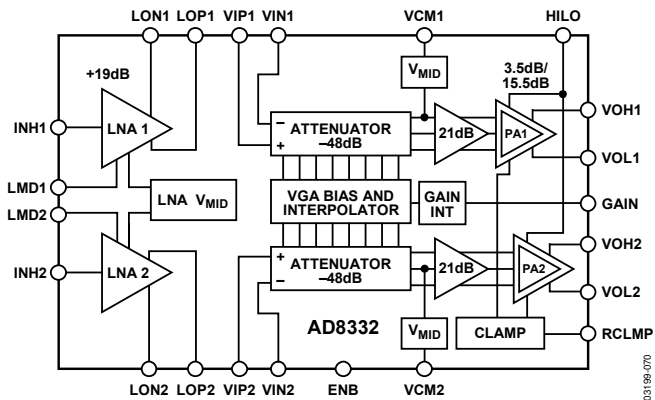

Figure 70. AD8332 Functional Block Diagram

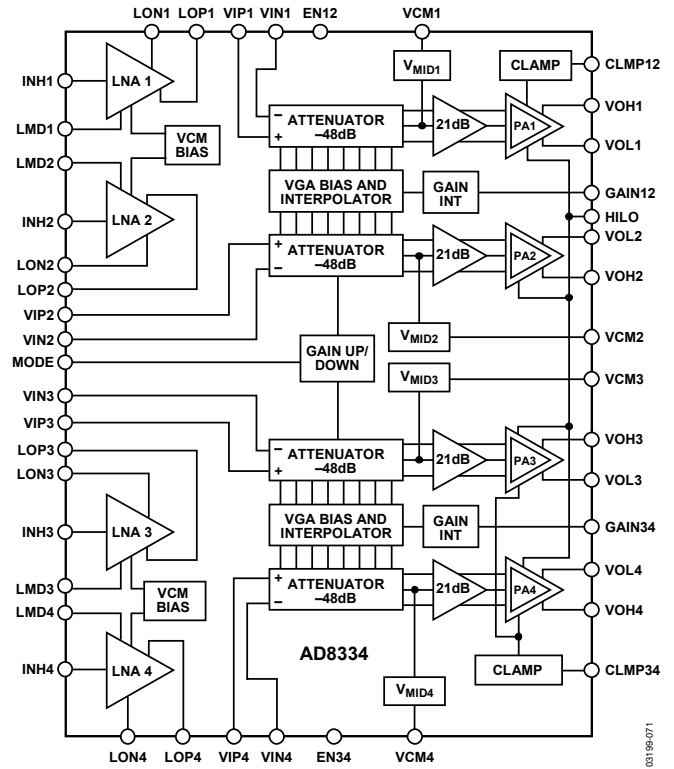

Figure 71. AD8334 Functional Block Diagram

Each channel contains an LNA that provides user-adjustable input impedance termination, a differential X-AMP VGA, and a programmable gain postamp with adjustable output voltage limiting. Figure 72 shows a simplified block diagram with external components.

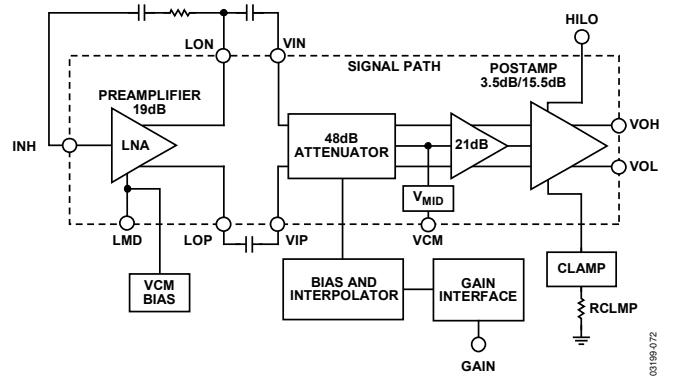

Figure 72. Simplified Block Diagram

Active Impedance Matching

The LNA supports active impedance matching through an external shunt feedback resistor from Pin LON to Pin INH. The input resistance, R_{IN} , is given in Equation 5, where A is the single-ended gain of 4.5, and $6\text{ k}\Omega$ is the unterminated input impedance.

$$R_{IN} = \frac{R_{IZ}}{1 + A} \parallel 6\text{ k}\Omega = \frac{6\text{ k}\Omega \times R_{IZ}}{33\text{ k}\Omega + R_{IZ}} \quad (5)$$

C_{IZ} is needed in series with R_{IZ} because the dc levels at Pin LON and Pin INH are unequal. Expressions for choosing R_{IZ} in terms of R_{IN} and for choosing C_{IZ} are found in the Applications Information section. C_{SH} and the ferrite bead enhance stability at higher frequencies, where the loop gain is diminished, and prevent peaking. Frequency response plots of the LNA are shown in Figure 23 and Figure 24. The bandwidth is approximately 130 MHz for matched input impedances of $50\ \Omega$ to $200\ \Omega$ and declines at higher source impedances. The unterminated bandwidth (when $R_{IZ} = \infty$) is approximately 80 MHz.

Each output can drive external loads as low as $100\ \Omega$ in addition to the $100\ \Omega$ input impedance of the VGA ($200\ \Omega$ differential). Capacitive loading up to 10 pF is permissible. All loads should be ac-coupled. Typically, Pin LOP output is used as a single-ended driver for auxiliary circuits, such as those used for Doppler ultrasound imaging. Pin LON drives R_{IZ} . Alternatively, a differential external circuit can be driven from the two outputs in addition to the active feedback termination. In both cases, important stability considerations discussed in the Applications Information section should be carefully observed.

The impedance at each LNA output is $5\ \Omega$. A 0.4 dB reduction in open circuit gain results when driving the VGA, and a 0.8 dB reduction results with an additional $100\ \Omega$ load at the output. The differential gain of the LNA is 6 dB higher. If the load is less than $200\ \Omega$ on either side, a compensating load is recommended on the opposite output.

LNA Noise

The input-referred voltage noise sets an important limit on system performance. The short-circuit input voltage noise of the LNA is $0.74\text{ nV}/\sqrt{\text{Hz}}$ or $0.82\text{ nV}/\sqrt{\text{Hz}}$ (at maximum gain), including the VGA noise. The open circuit, current noise is $2.5\text{ pA}/\sqrt{\text{Hz}}$. These measurements, taken without a feedback resistor, provide the basis for calculating the input noise and noise figure performance of the configurations in Figure 75. Figure 76 and Figure 77 show simulations extracted from these results and the 4.1 dB noise figure (NF) measurement with the input actively matched to a $50\ \Omega$ source. Unterminated ($R_{IZ} = \infty$) operation exhibits the lowest equivalent input noise and noise figure. Figure 76 shows the noise figure vs. source resistance, rising at low R_S , where the LNA voltage noise is large compared to the source noise, and again at high R_S due to current noise. The VGA input-referred voltage noise of $2.7\text{ nV}/\sqrt{\text{Hz}}$ is included in all of the curves.

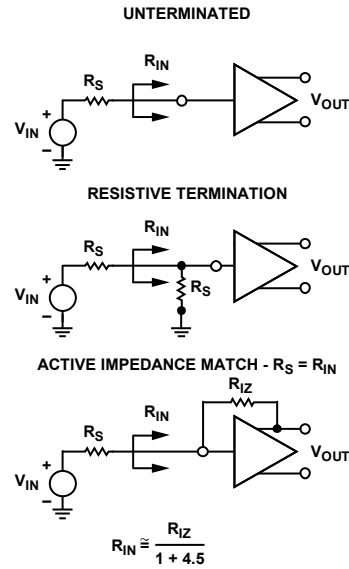

Figure 75. Input Configurations

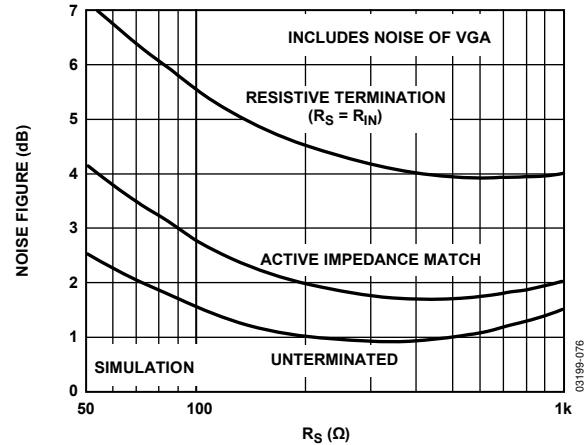

Figure 76. Noise Figure vs. R_S for Resistive, Active Match, and Unterminated Inputs

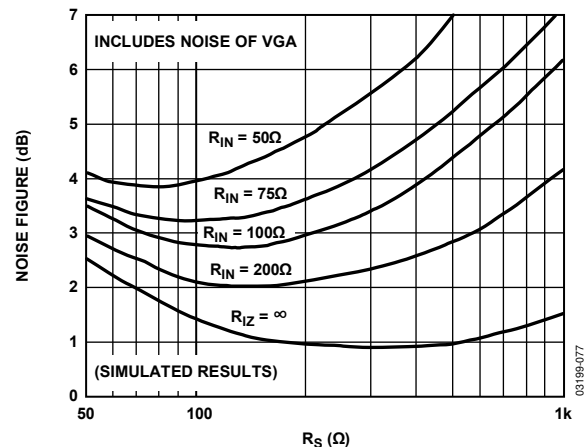

Figure 77. Noise Figure vs. R_S for Various Fixed Values of R_{IN} , Actively Matched

The primary purpose of input impedance matching is to improve the system transient response. With resistive termination, the input noise increases due to the thermal noise of the matching resistor and the increased contribution of the LNA input voltage noise generator. With active impedance matching, however, the contributions of both are smaller than they would be for resistive termination by a factor of $1/(1 + \text{LNA Gain})$. Figure 76 shows their relative NF performance. In this graph, the input impedance is swept with R_S to preserve the match at each point. The noise figures for a source impedance of $50\ \Omega$ are 7.1 dB, 4.1 dB, and 2.5 dB, respectively, for the resistive, active, and unterminated configurations. The noise figures for $200\ \Omega$ are 4.6 dB, 2.0 dB, and 1.0 dB, respectively.

Figure 77 is a plot of NF vs. R_S for various values of R_{IN} , which is helpful for design purposes. The plateau in the NF for actively matched inputs mitigates source impedance variations. For comparison purposes, a preamp with a gain of 19 dB and noise spectral density of $1.0\ \text{nV}/\sqrt{\text{Hz}}$, combined with a VGA with $3.75\ \text{nV}/\sqrt{\text{Hz}}$, yields a noise figure degradation of approximately 1.5 dB (for most input impedances), significantly worse than the AD8331/AD8332/AD8334 performance.

The equivalent input noise of the LNA is the same for single-ended and differential output applications. The LNA noise figure improves to 3.5 dB at $50\ \Omega$ without VGA noise, but this is exclusive of noise contributions from other external circuits connected to LOP. A series output resistor is usually recommended for stability purposes when driving external circuits on a separate board (see the Applications Information section). In low noise applications, a ferrite bead is even more desirable.

VARIABLE GAIN AMPLIFIER

The differential X-AMP VGA provides precise input attenuation and interpolation. It has a low input-referred noise of $2.7\ \text{nV}/\sqrt{\text{Hz}}$ and excellent gain linearity. A simplified block diagram is shown in Figure 78.

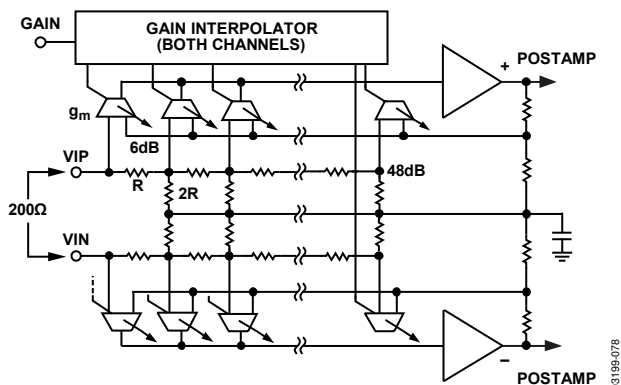

Figure 78. Simplified VGA Schematic

X-AMP VGA

The input of the VGA is a differential R-2R ladder attenuator network with 6 dB steps per stage and a net input impedance of $200\ \Omega$ differential. The ladder is driven by a fully differential input signal from the LNA and is not intended for single-ended operation. LNA outputs are ac-coupled to reduce offset and isolate their common-mode voltage. The VGA inputs are biased through the center tap connection of the ladder to VCM, which is typically set to 2.5 V and is bypassed externally to provide a clean ac ground.

The signal level at successive stages in the input attenuator falls from 0 dB to $-48\ \text{dB}$ in $+6\ \text{dB}$ steps. The input stages of the X-AMP are distributed along the ladder, and a biasing interpolator, controlled by the gain interface, determines the input tap point. With overlapping bias currents, signals from successive taps merge to provide a smooth attenuation range from 0 dB to $-48\ \text{dB}$. This circuit technique results in excellent linear-in-dB gain law conformance and low distortion levels and deviates $\pm 0.2\ \text{dB}$ or less from the ideal. The gain slope is monotonic with respect to the control voltage and is stable with variations in process, temperature, and supply.

The X-AMP inputs are part of a gain-of-12 feedback amplifier that completes the VGA. Its bandwidth is 150 MHz. The input stage is designed to reduce feedthrough to the output and to ensure excellent frequency response uniformity across gain setting (see Figure 12 and Figure 13).

Gain Control

Position along the VGA attenuator is controlled by a single-ended analog control voltage, V_{GAIN} , with an input range of 40 mV to 1.0 V. The gain control scaling is trimmed to a slope of 50 dB/V (20 mV/dB). Values of V_{GAIN} beyond the control range saturate to minimum or maximum gain values. Both channels of the AD8332 are controlled from a single gain interface to preserve matching. Gain can be calculated using Equation 1 and Equation 2.

Gain accuracy is very good because both the scaling factor and absolute gain are factory trimmed. The overall accuracy relative to the theoretical gain expression is $\pm 1\ \text{dB}$ for variations in temperature, process, supply voltage, interpolator gain ripple, trim errors, and tester limits. The gain error relative to a best-fit line for a given set of conditions is typically $\pm 0.2\ \text{dB}$. Gain matching between channels is better than 0.1 dB (Figure 11 shows gain errors in the center of the control range). When $V_{\text{GAIN}} < 0.1$ or > 0.95 , gain errors are slightly greater.

The gain slope can be inverted, as shown in Figure 73 (except for the AD8332 AR models). The gain drops with a slope of $-50\ \text{dB}/\text{V}$ across the gain control range from maximum to minimum gain. This slope is useful in applications such as automatic gain control, where the control voltage is proportional to the measured output signal amplitude. The inverse gain mode is selected by setting the MODE pin to HI gain mode.

Gain control response time is less than 750 ns to settle within 10% of the final value for a change from minimum to maximum gain.

VGA Noise

In a typical application, a VGA compresses a wide dynamic range input signal to within the input span of an ADC. While the input-referred noise of the LNA limits the minimum resolvable input signal, the output-referred noise, which depends primarily on the VGA, limits the maximum instantaneous dynamic range that can be processed at any one particular gain control voltage. This limit is set in accordance with the quantization noise floor of the ADC.

Output- and input-referred noise as a function of V_{GAIN} are plotted in Figure 25 and Figure 27 for the short circuited input conditions. The input noise voltage is simply equal to the output noise divided by the measured gain at each point in the control range.

The output-referred noise is flat over most of the gain range because it is dominated by the fixed output-referred noise of the VGA. Values are $48 \text{ nV}/\sqrt{\text{Hz}}$ in LO gain mode and $178 \text{ nV}/\sqrt{\text{Hz}}$ in HI gain mode. At the high end of the gain control range, the noise of the LNA and the noise of the source prevail. The input-referred noise reaches its minimum value near the maximum gain control voltage, where the input-referred contribution of the VGA becomes very small.

At lower gains, the input-referred noise, and thus noise figure, increases as the gain decreases. The instantaneous dynamic range of the system is not lost, however, because the input capacity increases with it. The contribution of the ADC noise floor has the same dependence as well. The important relationship is the magnitude of the VGA output noise floor relative to that of the ADC.

With its low output-referred noise levels, these devices ideally drive low voltage ADCs. The converter noise floor drops 12 dB for every two bits of resolution and drops at lower input full-scale voltages and higher sampling rates. ADC quantization noise is discussed in the Applications Information section.

The preceding noise performance discussion applies to a differential VGA output signal. Although the LNA noise performance is the same in single-ended and differential applications, the VGA performance is not. The noise of the VGA is significantly higher in single-ended usage because the contribution of its bias noise is designed to cancel in the differential signal. A transformer can be used with single-ended applications when low noise is desired.

Gain control noise is a concern in very low noise applications. Thermal noise in the gain control interface can modulate the channel gain. The resultant noise is proportional to the output signal level and usually only evident when a large signal is present. Its effect is observable only in LO gain mode where the noise floor is substantially lower. The gain interface includes an on-chip noise filter, which reduces this effect significantly at frequencies above 5 MHz. Care should be taken to minimize noise impinging at the GAIN input. An external RC filter can be used to remove V_{GAIN} source noise. The filter bandwidth should be sufficient to accommodate the desired control bandwidth.

Common-Mode Biasing

An internal bias network connected to a midsupply voltage establishes common-mode voltages in the VGA and postamp. An externally bypassed buffer maintains the voltage. The bypass capacitors form an important ac ground connection because the VCM network makes a number of important connections internally, including the center tap of the VGA differential input attenuator, the feedback network of the VGA fixed gain amplifier, and the feedback network of the postamp in both gain settings. For best results, use a 1 nF capacitor and a 0.1 μF capacitor in parallel, with the 1 nF capacitor nearest to the VCM pin. Separate VCM pins are provided for each channel. For dc coupling to a 3 V ADC, the output common-mode voltage is adjusted to 1.5 V by biasing the VCM pin.

POSTAMPLIFIER

The final stage has a selectable gain of 3.5 dB ($\times 1.5$) or 15.5 dB ($\times 6$), set by the HILO logic pin. Figure 79 is a simplified block diagram.

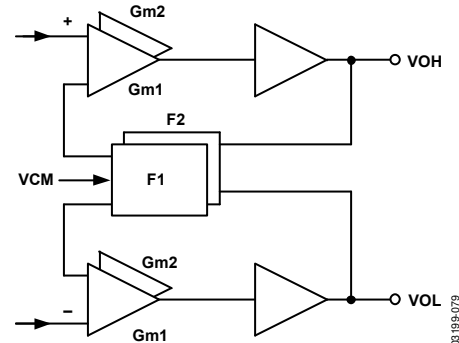

Figure 79. Postamplifier Block Diagram

Separate feedback attenuators implement the two gain settings. These are selected in conjunction with an appropriately scaled input stage to maintain a constant 3 dB bandwidth between the two gain modes ($\sim 150 \text{ MHz}$). The slew rate is $1200 \text{ V}/\mu\text{s}$ in HI gain mode and $300 \text{ V}/\mu\text{s}$ in LO gain mode. The feedback networks for HI and LO gain modes are factory trimmed to adjust the absolute gains of each channel.

Noise

The topology of the postamp provides constant input-referred noise with the two gain settings and variable output-referred noise. The output-referred noise in HI gain mode increases (with gain) by four. This setting is recommended when driving converters with higher noise floors. The extra gain boosts the output signal levels and noise floor appropriately. When driving circuits with lower input noise floors, the LO gain mode optimizes the output dynamic range.

Although the quantization noise floor of an ADC depends on a number of factors, the $48 \text{ nV}/\sqrt{\text{Hz}}$ and $178 \text{ nV}/\sqrt{\text{Hz}}$ levels are well suited to the average requirements of most 12-bit and 10-bit converters, respectively. An additional technique, described in the Applications Information section, can extend the noise floor even lower for possible use with 14-bit ADCs.

Output Clamping

Outputs are internally limited to a level of 4.5 V p-p differential when operating at a 2.5 V common-mode voltage. The postamp implements an optional output clamp engaged through a resistor from R_{CLMP} to ground. Table 8 shows a list of recommended resistor values.

Output clamping can be used for ADC input overload protection, if needed, or postamp overload protection when operating from a lower common-mode level, such as 1.5 V. The user should be aware that distortion products increase as output levels approach the clamping levels, and the user should adjust the clamp resistor accordingly. For additional information, see the Applications Information section.

The accuracy of the clamping levels is approximately $\pm 5\%$ in LO or HI mode. Figure 80 illustrates the output characteristics for a few values of R_{CLMP} .

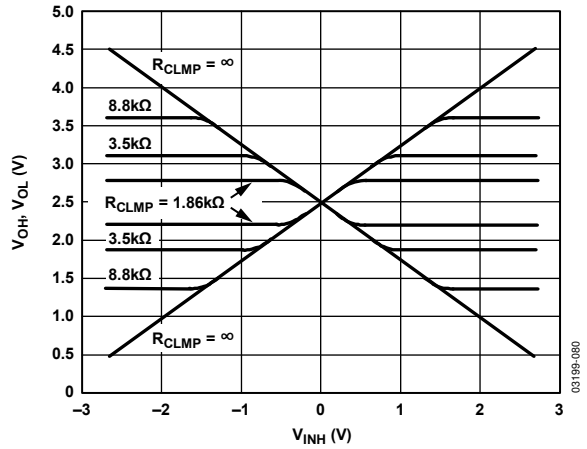

Figure 80. Output Clamping Characteristics

APPLICATIONS INFORMATION

LNA—EXTERNAL COMPONENTS

The LMD pin (connected to the bias circuitry) must be bypassed to ground and signal sourced to the INH pin, which is capacitively coupled using 2.2 nF to 0.1 μF capacitors (see Figure 81).

The unterminated input impedance of the LNA is 6 kΩ. The user can synthesize any LNA input resistance between 50 Ω and 6 kΩ. R_{IZ} is calculated according to Equation 6 or selected from Table 7.

$$R_{IZ} = \frac{33 \text{ k}\Omega \times (R_{IN})}{6 \text{ k}\Omega - (R_{IN})} \quad (6)$$

Table 7. LNA External Component Values for Common Source Impedances

R_{IN} (Ω)	R_{IZ} (Nearest STD 1% Value, Ω)	C_{SH} (pF)
50	280	22
75	412	12
100	562	8
200	1.13 k	1.2
500	3.01 k	None
6 k	∞	None

When active input termination is used, a decoupling capacitor (C_{IS}) is required to isolate the input and output bias voltages of the LNA.

The shunt input capacitor, C_{SH} , reduces gain peaking at higher frequencies where the active termination match is lost due to the gain roll-off of the LNA at high frequencies. The value of C_{SH} diminishes as R_{IN} increases to 500 Ω, at which point no capacitor is required. Suggested values for C_{SH} for $50 \Omega \leq R_{IN} \leq 200 \Omega$ are shown in Table 7.

When a long trace to Pin INH is unavoidable, or if both LNA outputs drive external circuits, a small ferrite bead (FB) in series with Pin INH preserves circuit stability with negligible effect on noise. The bead shown is 75 Ω at 100 MHz (Murata BLM21 or equivalent). Other values can prove useful.

Figure 82 shows the interconnection details of the LNA output. Capacitive coupling between the LNA outputs and the VGA inputs is required because of the differences in their dc levels and the need to eliminate the offset of the LNA. Capacitor values of 0.1 μF are recommended. There is a 0.4 dB loss in gain between the LNA output and the VGA input due to the 5 Ω output resistance. Additional loading at the LOP and LON outputs affects LNA gain.

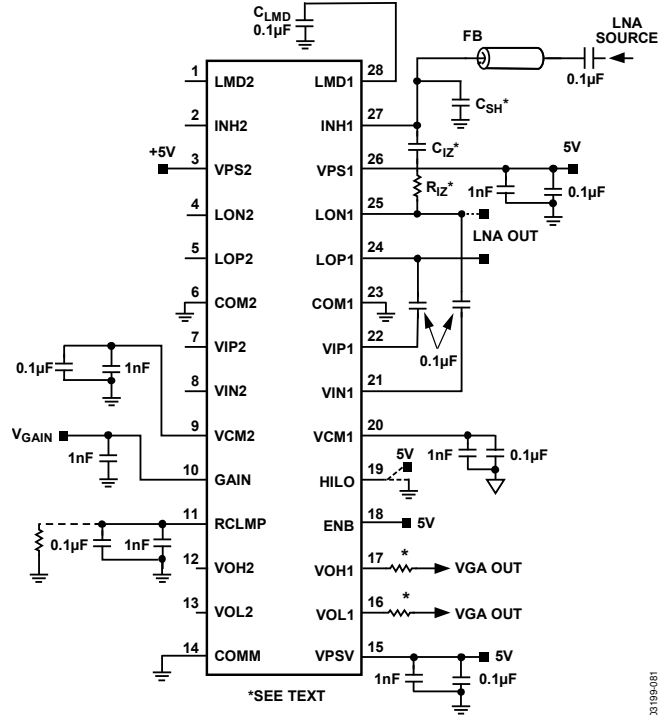

Figure 81. Basic Connections for a Typical Channel (AD8332 Shown)

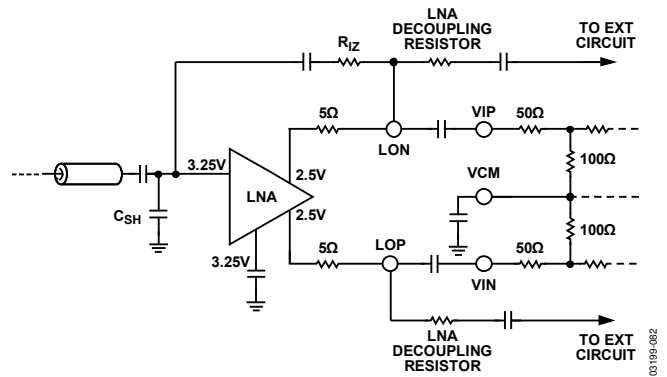

Figure 82. Interconnections of the LNA and VGA

Both LNA outputs are available for driving external circuits. Pin LOP should be used in those instances when a single-ended LNA output is required. The user should be aware of stray capacitance loading of the LNA outputs, in particular LON. The LNA can drive 100 Ω in parallel with 10 pF. If an LNA output is routed to a remote PC board, it tolerates a load capacitance up to 100 pF with the addition of a 49.9 Ω series resistor or ferrite 75 Ω/100 MHz bead.

Gain Input

The GAIN pin is common to both channels of the AD8332. The input impedance is nominally 10 MΩ, and a bypass capacitor from 100 pF to 1 nF is recommended.

Parallel connected devices can be driven by a common voltage source or DAC. Decoupling should take into account any bandwidth considerations of the drive waveform, using the total distributed capacitance.

If gain control noise in LO gain mode becomes a factor, maintaining $\leq 15 \text{ nV}/\sqrt{\text{Hz}}$ noise at the GAIN pin ensures satisfactory noise performance. Internal noise prevails below $15 \text{ nV}/\sqrt{\text{Hz}}$ at the GAIN pin. Gain control noise is negligible in HI gain mode.

VCM Input

The common-mode voltage of Pin VCM, Pin VOL, and Pin VOH defaults to 2.5 V dc. With output ac-coupled applications, the VCM pin is unterminated; however, it must still be bypassed in close proximity for ac grounding of internal circuitry. The VGA outputs can be dc connected to a differential load, such as an ADC. Common-mode output voltage levels between 1.5 V and 3.5 V can be realized at Pin VOH and Pin VOL by applying the desired voltage at Pin VCM. DC-coupled operation is not recommended when driving loads on a separate PC board.

The voltage on the VCM pin is sourced by an internal buffer with an output impedance of 30 Ω and a $\pm 2 \text{ mA}$ default output current (see Figure 83). If the VCM pin is driven from an external source, its output impedance should be $\ll 30 \text{ } \Omega$, and its current drive capability should be $\gg 2 \text{ mA}$. If the VCM pins of several devices are connected in parallel, the external buffer should be capable of overcoming their collective output currents. When a common-mode voltage other than 2.5 V is used, a voltage-limiting resistor, R_{CLMP} , is needed to protect against overload.

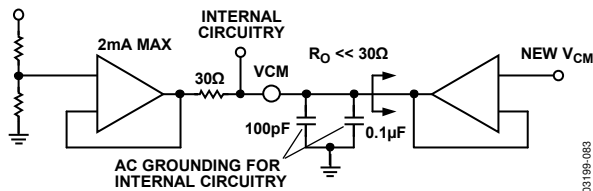

Figure 83. VCM Interface

Logic Inputs—ENB, MODE, and HILO

The input impedance of all enable pins is nominally 25 kΩ and can be pulled up to 5 V (a pull-up resistor is recommended) or driven by any 3 V or 5 V logic families. The enable pin, ENB, powers down the VGA; when pulled low, the VGA output voltages are near ground. Multiple devices can be driven from a common source. Consult Table 3, Table 4, Table 5, and Table 6 for information about circuit functions controlled by the enable pins.

Pin HILO is compatible with 3 V or 5 V CMOS logic families. It is either connected to ground or pulled up to 5 V, depending on the desired gain range and output noise.

Optional Output Voltage Limiting

The RCLMP pin provides the user with a means to limit the output voltage swing when used with loads that have no provisions for prevention of input overdrive. The peak-to-peak limited voltage is adjusted by a resistor to ground (see Table 8 for a list of several voltage levels and corresponding resistor values). Unconnected, the default limiting level is 4.5 V p-p.

Note that third harmonic distortion increases as waveform amplitudes approach clipping. For lowest distortion, the clamp level should be set higher than the converter input span. A clamp level of 1.5 V p-p is recommended for a 1 V p-p linear output range, 2.7 V p-p for a 2 V p-p range, or 1 V p-p for a 0.5 V p-p operation. The best solution is determined experimentally. Figure 84 shows third harmonic distortion as a function of the limiting level for a 2 V p-p output signal. A wider limiting level is desirable in HI gain mode.

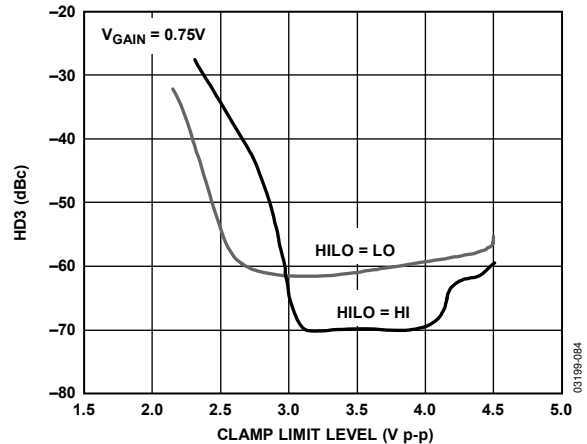

Figure 84. HD3 vs. Clamping Level for 2 V p-p Differential Input

Table 8. Clamp Resistor Values

Clamp Level (V p-p)	Clamp Resistor Value (kΩ)	
	HILO = LO	HILO = HI
0.5	1.21	
1.0	2.74	2.21
1.5	4.75	4.02
2.0	7.5	6.49
2.5	11	9.53
3.0	16.9	14.7
3.5	26.7	23.2
4.0	49.9	39.2
4.4	100	73.2

Output Decoupling

When driving capacitive loads greater than about 10 pF, or long circuit connections on other boards, an output network of resistors and/or ferrite beads can be useful to ensure stability. These components can be incorporated into a Nyquist filter such as the one shown in Figure 81. In Figure 81, the resistor value is 84.5 Ω. For example, all the evaluation boards for this series incorporate 100 Ω in parallel with a 120 nH bead. Lower value resistors are permissible for applications with nearby loads or

AD8331/AD8332/AD8334

with gains less than 40 dB. The exact values of these components can be selected empirically.

An antialiasing noise filter is typically used with an ADC. Filter requirements are application dependent.

When the ADC resides on a separate board, the majority of filter components should be placed nearby to suppress noise picked up between boards and to mitigate charge kickback from the ADC inputs. Any series resistance beyond that required for output stability should be placed on the ADC board. Figure 85 shows a second-order, low-pass filter with a bandwidth of 20 MHz. The capacitor is chosen in conjunction with the 10 pF input capacitance of the ADC.

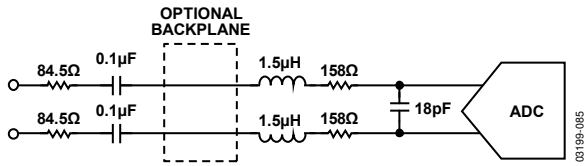

Figure 85. 20 MHz Second-Order, Low-Pass Filter

DRIVING ADCs

The output drive accommodates a wide range of ADCs. The noise floor requirements of the VGA depend on a number of application factors, including bit resolution, sampling rate, full-scale voltage, and the bandwidth of the noise/antialias filter. The output noise floor and gain range can be adjusted by selecting HI or LO gain mode.

The relative noise and distortion performance of the two gain modes can be compared in Figure 25 and Figure 31 through Figure 41. The 48 nV/√Hz noise floor of the LO gain mode is suited to converters with higher sampling rates or resolutions (such as 12 bits). Both gain modes can accommodate ADC full-scale voltages as high as 4 V p-p. Because distortion performance remains favorable for output voltages as high as 4 V p-p (see Figure 36), it is possible to lower the output-referred noise even further by using a resistive attenuator (or transformer) at the output. The circuit in Figure 86 has an output full-scale range of 2 V p-p, a gain range of -10.5 dB to +37.5 dB, and an output noise floor of 24 nV/√Hz, making it suitable for some 14-bit ADC applications.

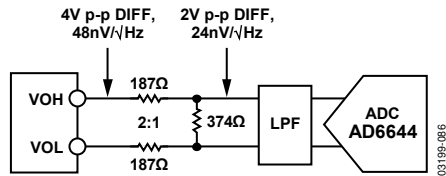

Figure 86. Adjusting the Noise Floor for 14-Bit ADCs

OVERLOAD

These devices respond gracefully to large signals that overload its input stage and to normal signals that overload the VGA when the gain is set unexpectedly high. Each stage is designed for clean-limited overload waveforms and fast recovery when gain setting or input amplitude is reduced.

Signals larger than ±275 mV at the LNA input are clipped to 5 V p-p differential prior to the input of the VGA. Figure 48 shows the response to a 1 V p-p input burst. The symmetric overload waveform is important for applications, such as CW Doppler ultrasound, where the spectrum of the LNA outputs during overload is critical. The input stage is also designed to accommodate signals as high as ±2.5 V without triggering the slow-settling ESD input protection diodes.

Both stages of the VGA are susceptible to overload. Post-amplifier limiting is more common and results in the clean-limited output characteristics found in Figure 49. Recovery is fast in all cases. The graph in Figure 87 summarizes the combinations of input signal and gain that lead to the different types of overload.

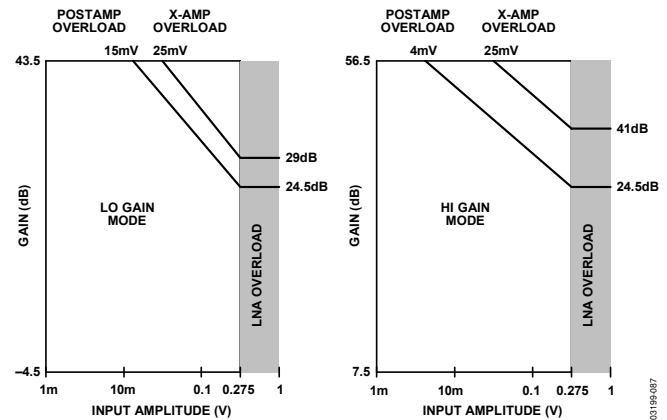

Figure 87. Overload Gain and Signal Conditions

The clamp interface mentioned in the Output Clamping section controls the maximum output swing of the postamp and its overload response. When the clamp feature is not used, the output level defaults to approximately 4.5 V p-p differential centered at 2.5 V common mode. When other common-mode levels are set through the VCM pin, the value of R_{CLMP} should be selected for graceful overload. A value of 8.3 kΩ or less is recommended for 1.5 V or 3.5 V common-mode levels (7.2 kΩ for HI gain mode). This limits the output swing to just above 2 V p-p differential.

OPTIONAL INPUT OVERLOAD PROTECTION

Applications in which high transients are applied to the LNA input can benefit from the use of clamp diodes. A pair of back-to-back Schottky diodes can reduce these transients to manageable levels. Figure 88 illustrates how such a diode protection scheme can be connected.

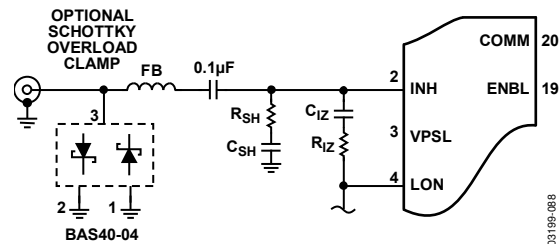

Figure 88. Input Overload Clamping

When selecting overload protection, the important parameters are forward and reverse voltages and t_{rr} (or τ_{rr}). The Infineon BAS40-04 series shown in Figure 88 has a τ_{rr} of 100 ps and a V_F of 310 mV at 1 mA. Many variations of these specifications can be found in vendor catalogs.

LAYOUT, GROUNDING, AND BYPASSING

Due to their excellent high frequency characteristics, these devices are sensitive to their PCB environments. Realizing expected performance requires attention to detail critical to good, high speed, board design.

A multilayer board with power and ground planes is recommended with blank areas in the signal layers filled with ground plane. Be certain that the power and ground pins provided for robust power distribution to the device are connected. Decouple the power supply pins with surface-mount capacitors as close as possible to each pin to minimize impedance paths to ground. Decouple the LNA power pins from the VGA supply using ferrite beads. Together with the capacitors, ferrite beads eliminate undesired high frequencies without reducing the headroom. Use a larger value capacitor for every 10 chips to 20 chips to decouple residual low frequency noise. To minimize voltage drops, use a 5 V regulator for the VGA array.

Several critical LNA areas require special care. The LON and LOP output traces must be as short as possible before connecting to the coupling capacitors connected to Pin VIN and Pin VIP. R_{IZ} must be placed near the LON pin as well. Resistors must be placed as close as possible to the VGA output pins, VOL and VOH, to mitigate loading effects of connecting traces. Values are discussed in the Output Decoupling section.

Signal traces must be short and direct to avoid parasitic effects. Wherever there are complementary signals, symmetrical layout should be employed to maintain waveform balance. PCB traces should be kept adjacent when running differential signals over a long distance.

MULTIPLE INPUT MATCHING

Matching of multiple sources with dissimilar impedances can be accomplished as shown in Figure 89. A relay and low supply voltage analog switch can be used to select between multiple sources and their associated feedback resistors. An ADG736 dual SPDT switch is shown in this example; however, multiple switches are also available and users are referred to the [Analog Devices Selection Guide](#) for switches and multiplexers.

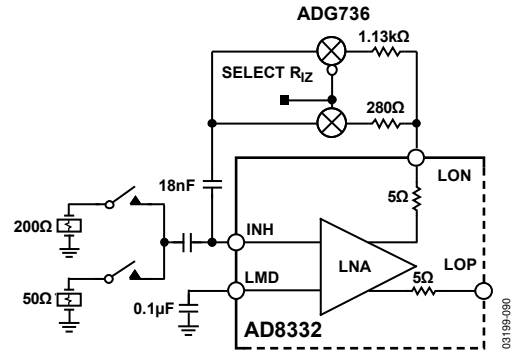

Figure 89. Accommodating Multiple Sources

DISABLING THE LNA

Where accessible, connection of the LNA enable pin to ground powers down the LNA, resulting in a current reduction of about half. In this mode, the LNA input and output pins can be left unconnected; however, the power must be connected to all the supply pins for the disabling circuit to function. Figure 90 illustrates the connections using AD8331 as an example.

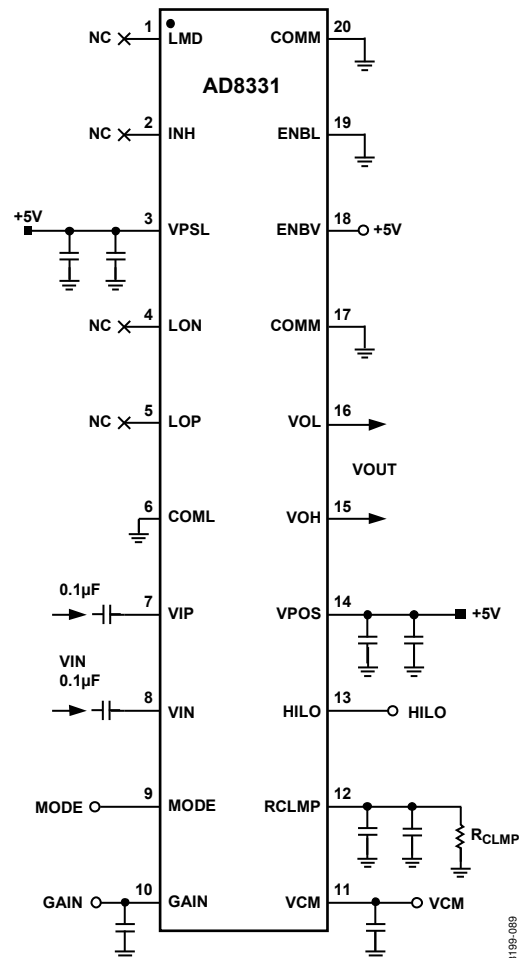

Figure 90. Disabling the LNA

ULTRASOUND TGC APPLICATION

The [AD8332](#) ideally meets the requirements of medical and industrial ultrasound applications. The TGC amplifier is a key subsystem in such applications because it provides the means for echo location of reflected ultrasound energy.

Figure 91 through Figure 93 are schematics of a dual, fully differential system using the AD8332 and the [AD9238](#) 12-bit high speed ADC with conversion speeds as high as 65 MSPS.

HIGH DENSITY QUAD LAYOUT

The [AD8334](#) is the ideal solution for applications with limited board space. Figure 94 represents four channels routed to and away from this very compact quad VGA. Note that none of the signal paths crosses and that all four channels are spaced apart to eliminate crosstalk.

In this example, all of the components shown are 0402 size; however, the same layout is executable at the expense of slightly more board area. The sketch also assumes that both sides of the printed circuit board are available for components and that the bypass and power supply decoupling circuitry is located on the wiring side of the board.

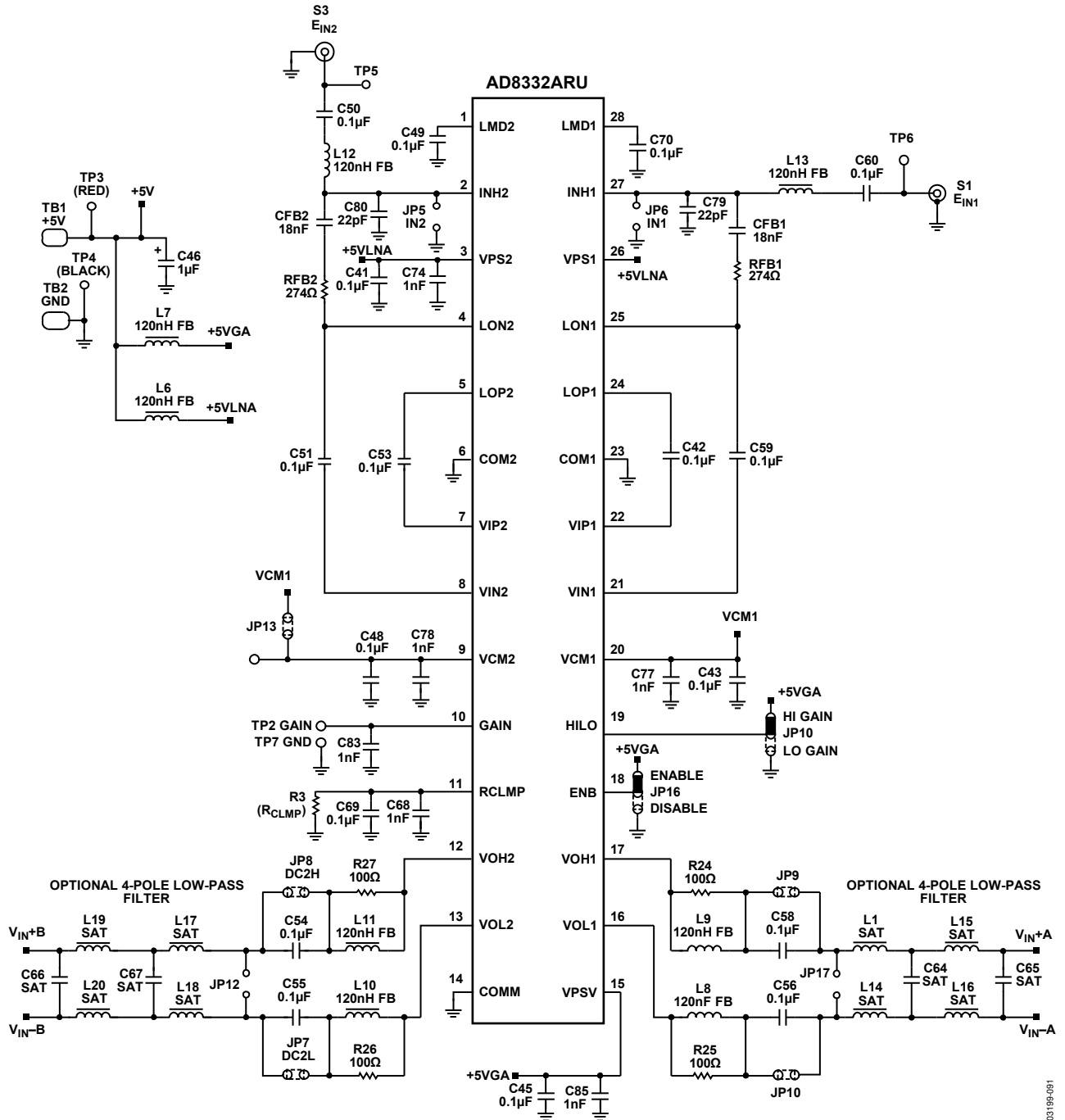

Figure 91. Schematic, TGC, VGA Section Using an AD8332 and AD9238

03199-091

AD8331/AD8332/AD8334

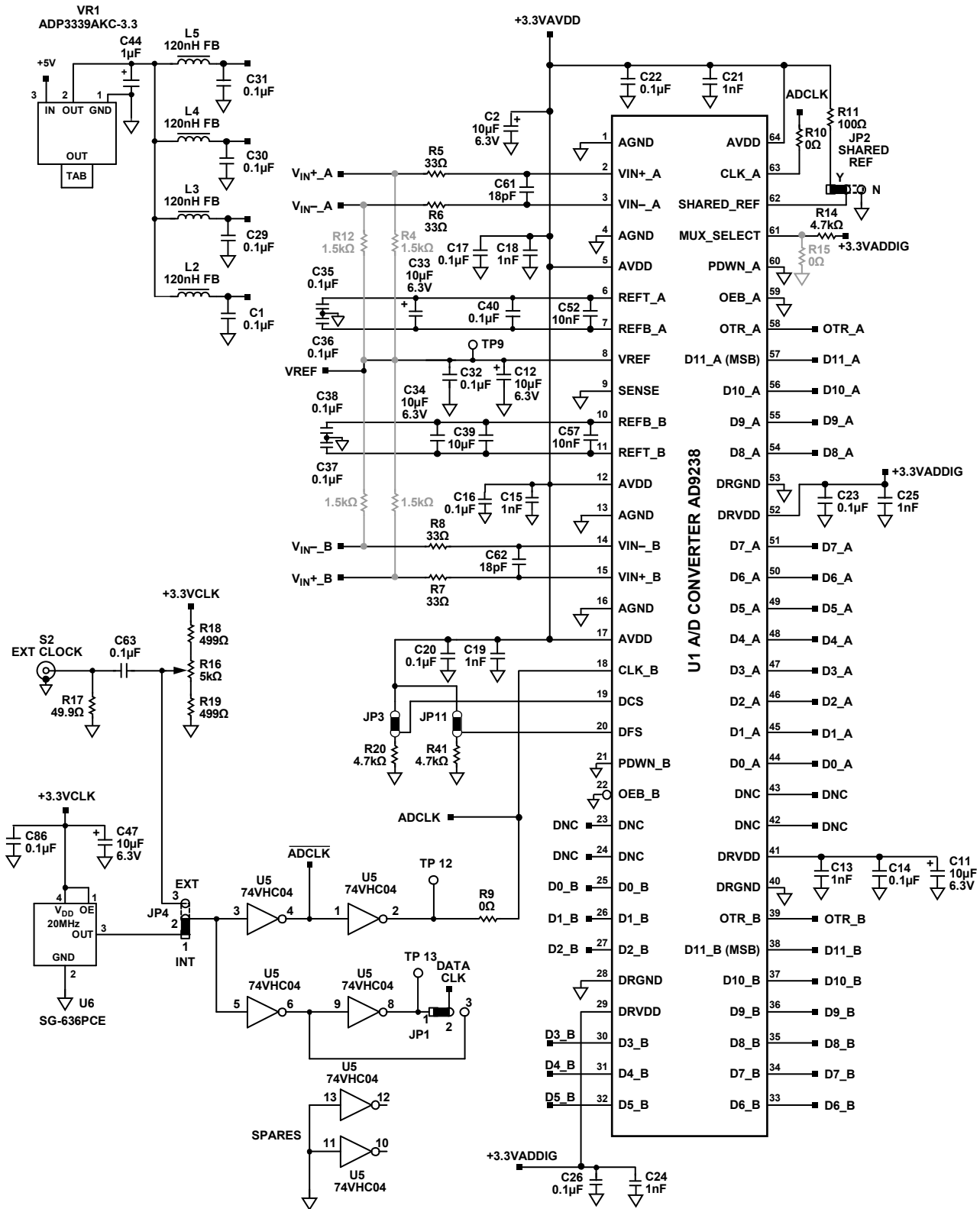

Figure 92. Converter Schematic, TGC Using an AD8332 and AD9238

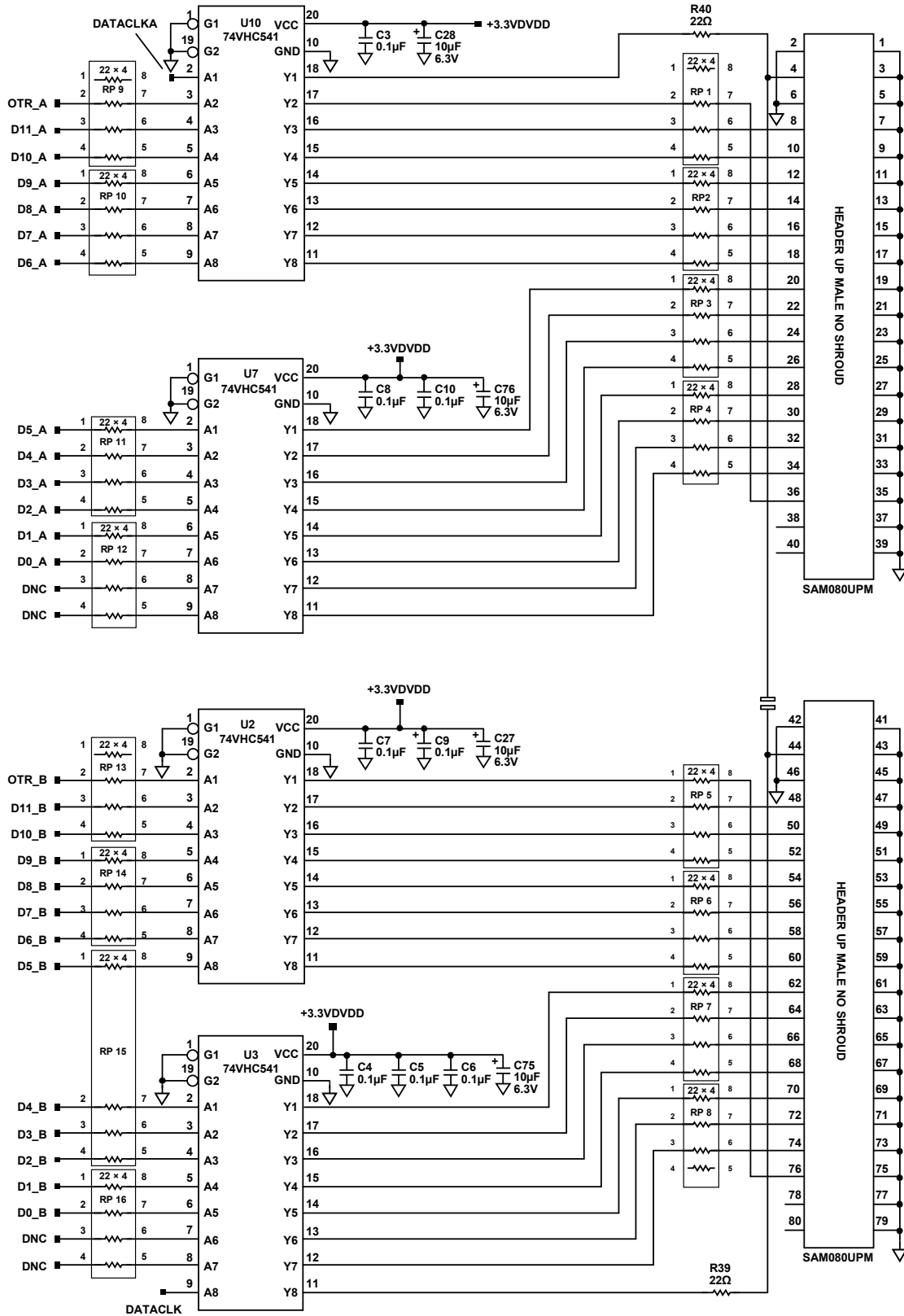

Figure 93. Interface Schematic, TGC Using an AD8332 and AD9238

AD8331/AD8332/AD8334

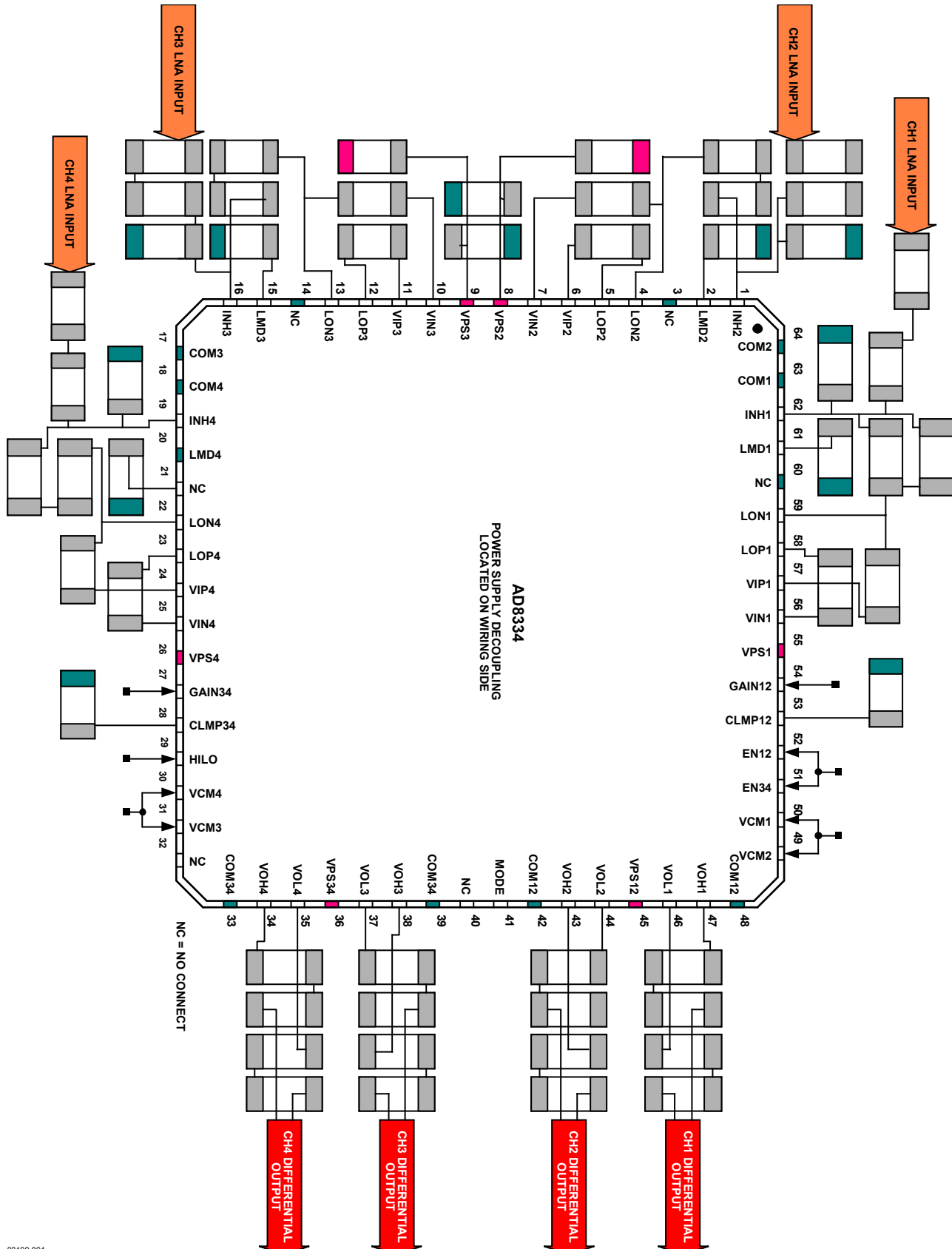

Figure 94. Compact Signal Path and Board Layout for the AD8334

03199-094

AD8331 EVALUATION BOARD

GENERAL DESCRIPTION

The AD8331 evaluation board is a platform for testing and evaluating the AD8331 variable gain amplifier (VGA). The board is provided completely assembled and tested; the user simply connects an input signal, VGAIN sources, and a 5 V power supply. The AD8331-EVALZ is lead free and RoHS compliant. Figure 95 is a photograph of the board.

USER-SUPPLIED OPTIONAL COMPONENTS

As shown in the schematic in Figure 96, the board provides for optional components. The components shown in black are for typical operation, and the components shown in gray are installed at the user's discretion.

As shipped, the LNA input impedance of the AD8331-EVALZ is configured for 50 Ω to accommodate most signal generators and network analyzers. Input impedances up to 6 k Ω are realized by changing the values of RFB and CSH. Refer to the Theory of Operation section for details on this circuit feature. See Table 9 for typical values of input impedance and corresponding components.

Table 9. LNA External Component Values for Common Source Impedances

R _{IN} (Ω)	RFB (Ω , Nearest 1% Value)	CSH (pF)
50	274	22
75	412	12
100	562	8
200	1.13 k	1.2
500	3.01 k	None
6 k	∞	None

The board is designed for 0603 size, surface-mount components. Back-to-back diodes can be installed at Location D3 if desired.

To evaluate the LNA as a standalone amplifier, install optional SMA connectors LON and LOP and capacitors C1 and C2; typical values are 0.1 μ F or smaller. At R4 and R8, 0 Ω resistors are installed unless capacitive loads larger than 10 pF are connected to the SMA connectors LON and LOP (such as coaxial cables). In that event, small value resistors (68 Ω to 100 Ω) must be installed at R4 and R8 to preserve the stability of the amplifier.

A resistor can be inserted at RCLMP if output clamping is desired. Refer to Table 8 for appropriate values.



Figure 95. Photograph of AD8331-EVALZ

MEASUREMENT SETUP

The basic board connection for measuring bandwidth is shown in Figure 97. A 5 V, 100 mA minimum power supply and a low noise, voltage reference supply for GAIN are required. Table 10 lists jumpers, and Figure 97 shows their functions and positions.

The preferred signal detection method is a differential probe connected to VO, as shown in Figure 97. Single-ended loads can be connected using the board edge SMA connector, VOH. Be sure to take into account the 25.8 dB attenuation incurred when using the board in this manner. For connection to an ADC, the 270 Ω series resistors can be replaced with 0 Ω or other appropriate values.

Table 10. Jumper Functions

Switch	Function
LNA_EN	Enables the LNA when in the top position
VGA_EN	Enables the VGA when in the top position
W5, W6	Connects the AD8331 outputs to the SMA connectors
GN_SLOPE	Left = gain increases with V _{GAIN} Right = gain decreases with V _{GAIN}
GN_HI_LO	Left = high gain Right = LO gain

BOARD LAYOUT

The evaluation board circuitry uses four conductor layers. The two inner layers are grounded, and all interconnecting circuitry is located on the outer layers. Figure 99 to Figure 102 illustrate the copper patterns.

AD8331/AD8332/AD8334

AD8331 EVALUATION BOARD SCHEMATICS

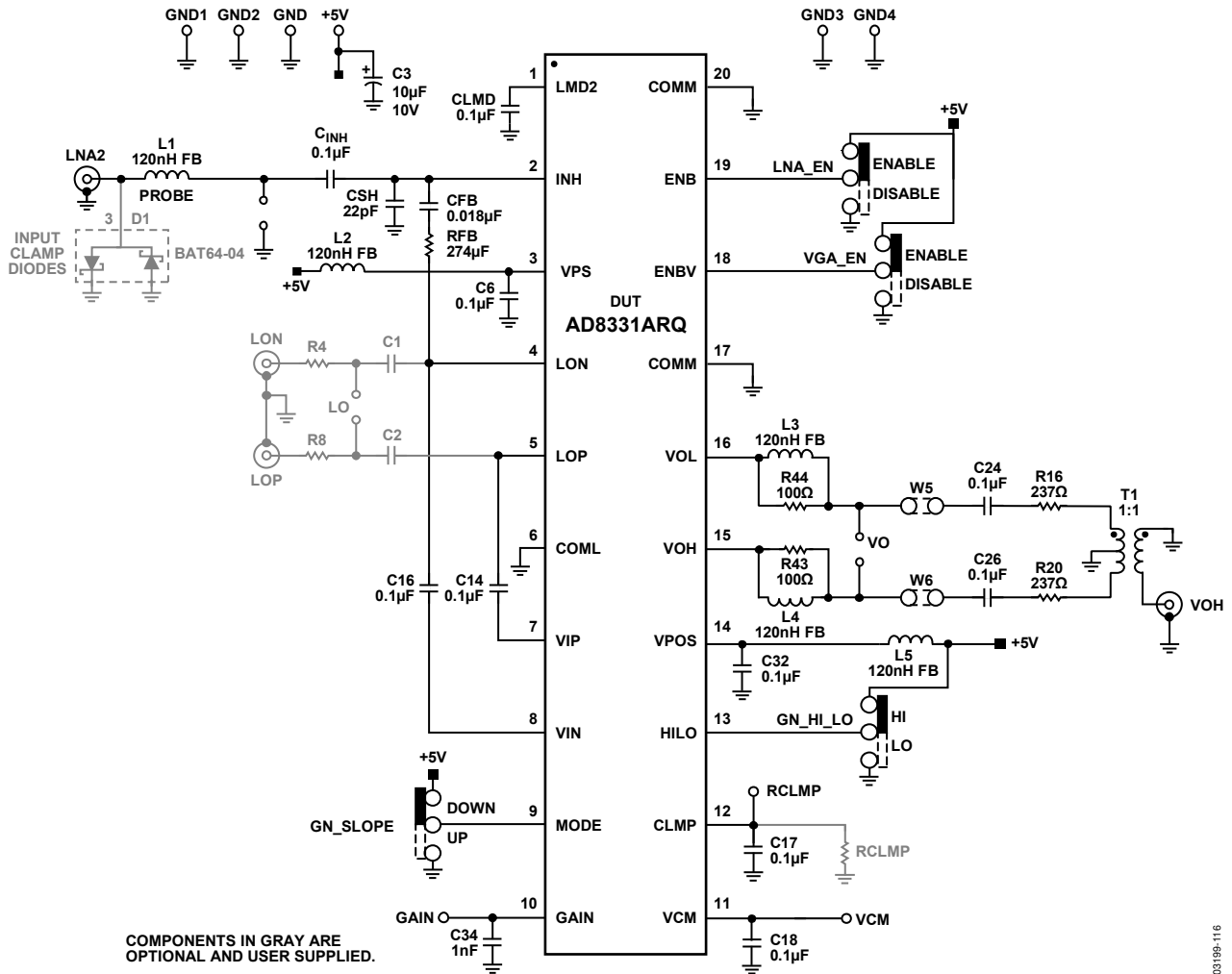

Figure 96. Schematic of the AD8331 Evaluation Board

03199-116

AD8331/AD8332/AD8334

AD8331 EVALUATION BOARD PCB LAYERS

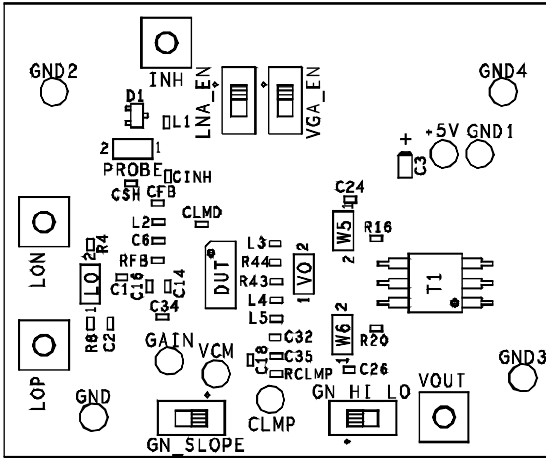

Figure 98. AD8331-EVALZ Assembly

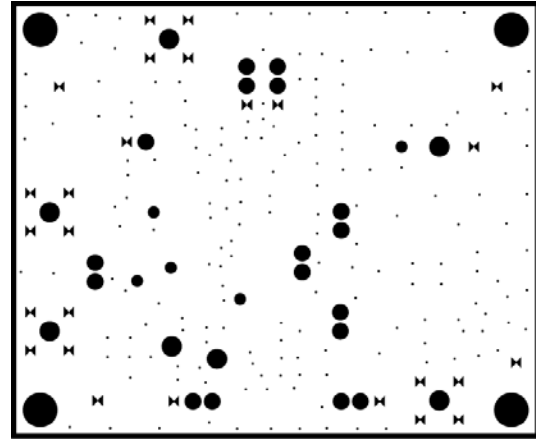

Figure 101. Internal Layer Ground

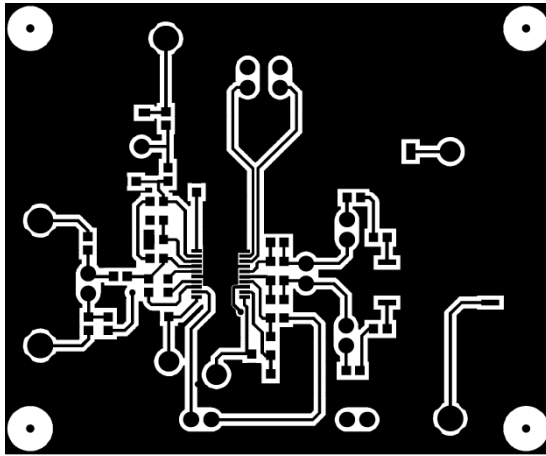

Figure 99. Primary Side Copper

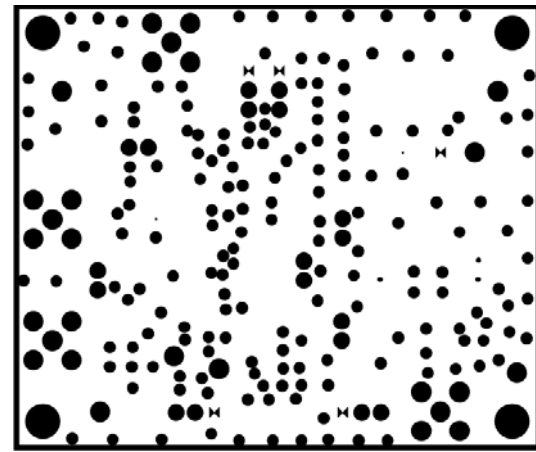

Figure 102. Power Plane

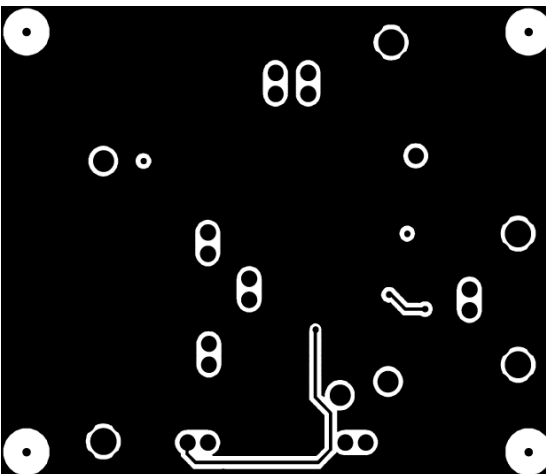

Figure 100. Secondary Side Copper

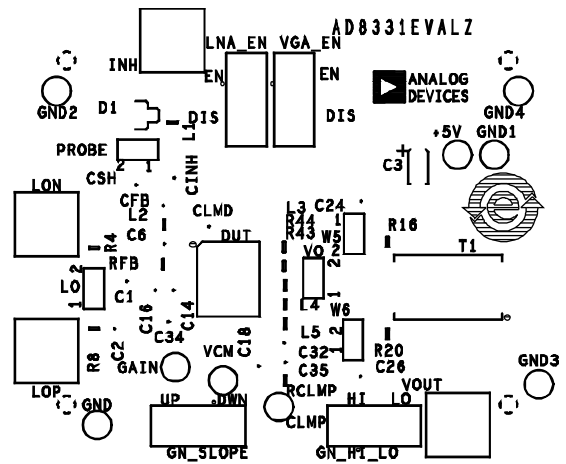

Figure 103. Top Silkscreen

AD8332 EVALUATION BOARD

GENERAL DESCRIPTION

The AD8332-EVALZ is a platform for the testing and evaluation of the [AD8332](#) variable gain amplifier (VGA). The board is shipped assembled and tested, and users need only connect the signal and VGAIN sources to a single 5 V power supply. Figure 104 is a photograph of the component side of the board, and Figure 105 shows the schematic. The AD8332-EVALZ is lead free and RoHS compliant.

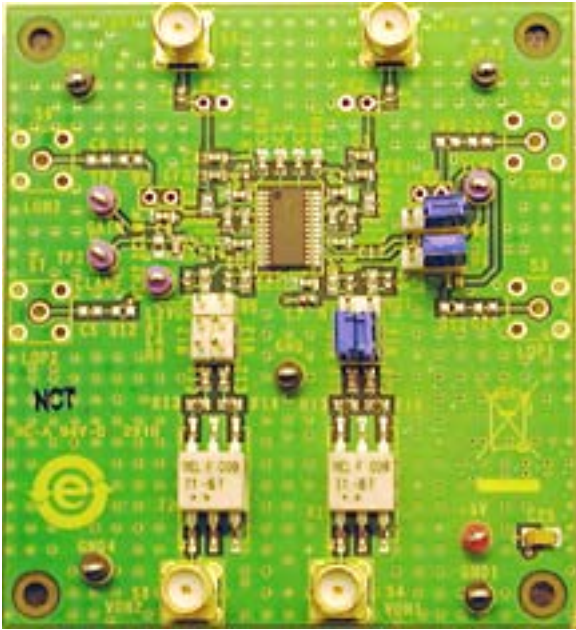

Figure 104. Photograph of the AD8332-EVALZ

USER-SUPPLIED OPTIONAL COMPONENTS

The board is built and tested using the components shown in black in Figure 105. Provisions are made for optional components (shown in gray) that can be installed for testing at user discretion. The default LNA input impedance is 50 Ω to match various signal generators and network analyzers. Input impedances up to 6 k Ω are realized by changing the values of RFBx and CSHx. For reference, Table 11 lists the common input impedance values and corresponding adjustments. The board is designed for 0603 size, surface-mount components.

Table 11. LNA External Component Values for Common Source Impedances

R _{IN} (Ω)	RFB1, RFB2 (Ω Std 1% Value)	CSH1, CSH2 (pF)
50	274	22
75	412	12
100	562	8
200	1.13 k	1.2
500	3.01 k	None
6 k	∞	None

SMA connectors, S2, S3, S6, and S7, are provided for access to the LNA outputs or the VGA inputs. If the LNA is used alone, 0.1 μ F coupling capacitors can be installed at the C5, C9, C23, and C24 locations. Resistors of 68 Ω to 100 Ω may be required if the load capacitances, as seen by the LNA outputs, are larger than approximately 10 pF.

A resistor can be inserted at RCLMP if output clamping is desired. The peak-to-peak clamping level is adjusted by installing one of the standard 1% resistor values listed in Table 8.

A high frequency differential probe connected to the 2-pin headers, VOx, is the preferred method to observe a waveform at the VGA output. A typical setup is shown in Figure 106. Single-ended loads can be connected directly via the board edge SMA connectors. Note that the AD8332 output amplifier is buffered with 237 Ω resistors; therefore, be sure to compensate for attenuation if low impedances are connected to the output SMAs.

MEASUREMENT SETUP

The basic board connections for measuring bandwidth are shown in Figure 106. A 5 V, 100 mA (minimum) power supply is required, and a low noise voltage reference supply is required for VGAIN.

BOARD LAYOUT

The evaluation board circuitry uses four conductor layers. The two inner layers are power and ground planes, and all interconnecting circuitry is located on the outer layers. Figure 108 to Figure 111 illustrate the copper patterns.

AD8331/AD8332/AD8334

EVALUATION BOARD SCHEMATICS

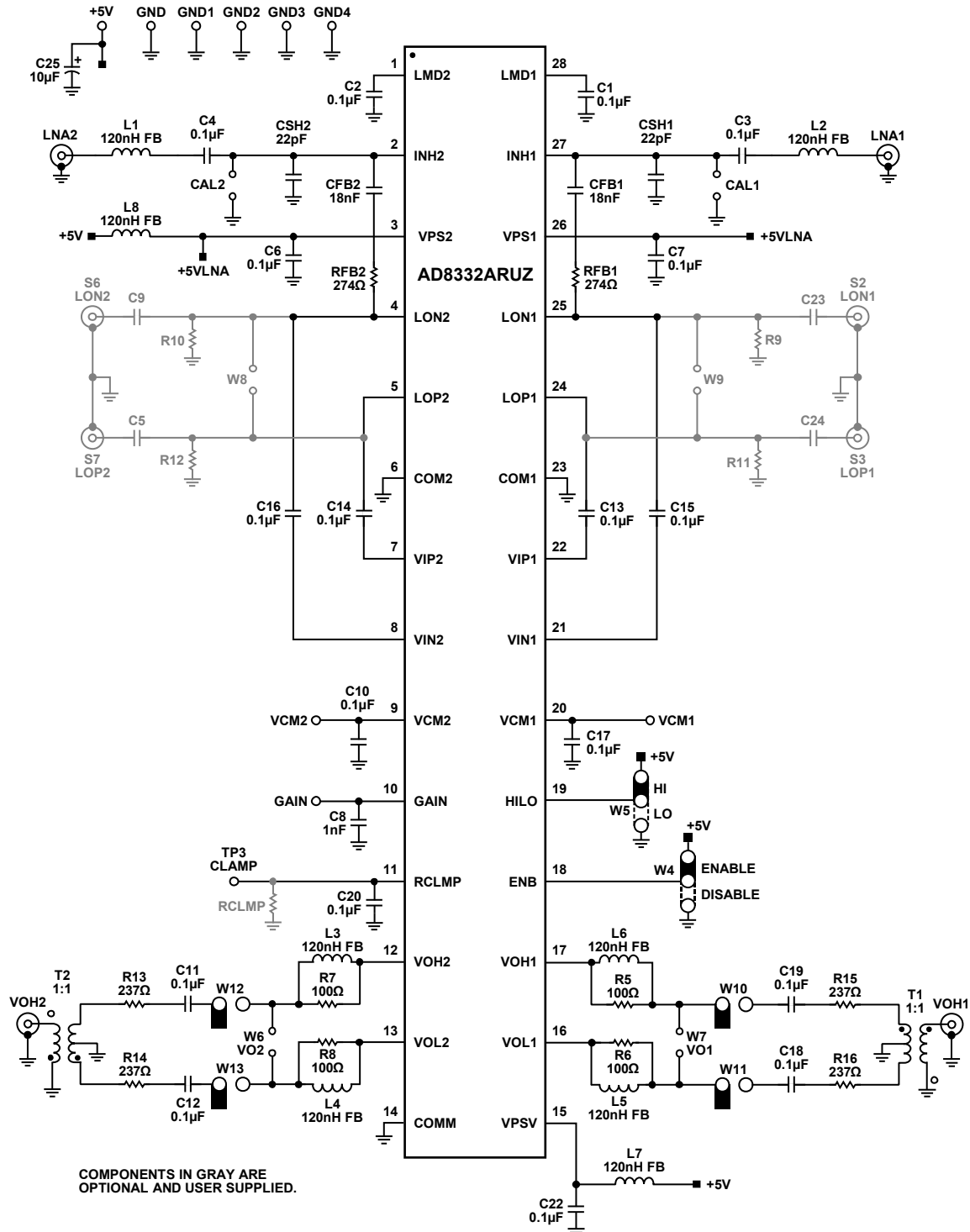

Figure 105. Schematic of the AD8332 Evaluation Board

031999-096

AD8331/AD8332/AD8334

AD8332 EVALUATION BOARD PCB LAYERS

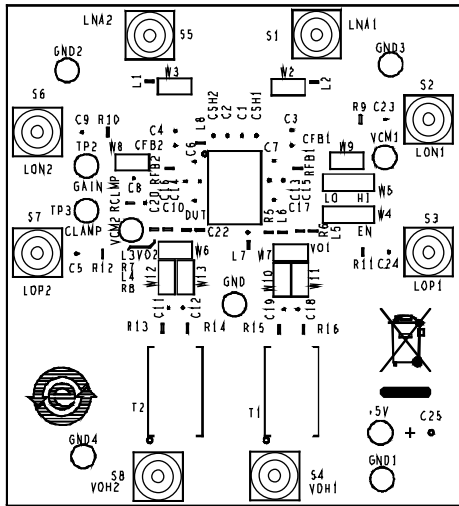

Figure 107. AD8332-EVALZ Assembly

03199-121

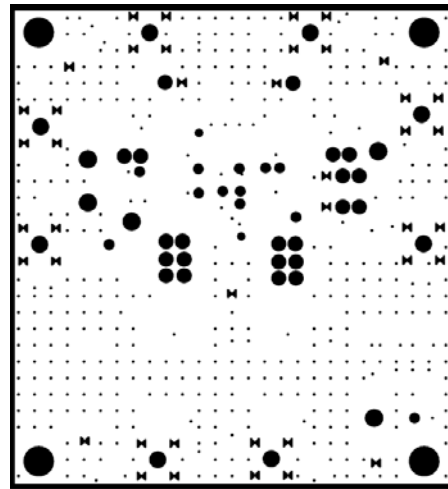

Figure 110. Ground Plane

03199-101

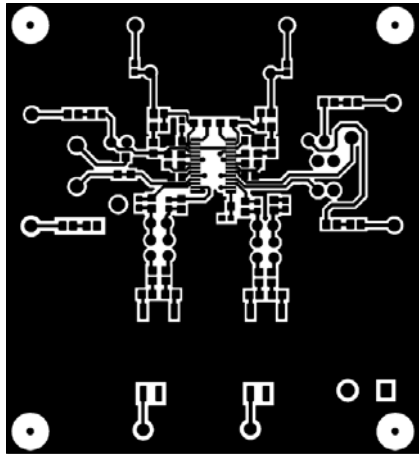

Figure 108. Primary Side Copper

03199-099

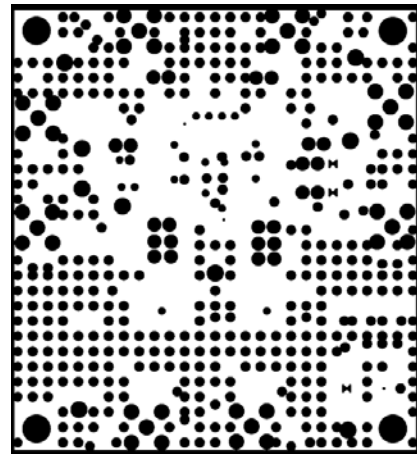

Figure 111. Power Plane

03199-102

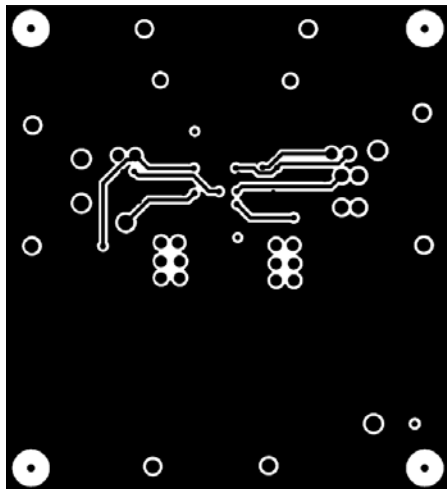

Figure 109. Secondary Side Copper

03199-100

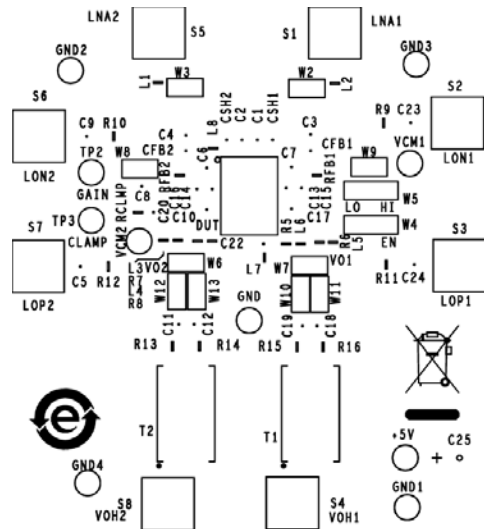

Figure 112. Component Side Silkscreen

03199-103

AD8334 EVALUATION BOARD

GENERAL DESCRIPTION

The AD8334-EVALZ is a platform for the testing and evaluation of the [AD8334](#) variable gain amplifier (VGA). The board is shipped assembled and tested, and users need only connect the signal and VGAIN sources and a single 5 V power supply. Figure 113 is a photograph of the board. The AD8334-EVALZ is lead free and RoHS compliant.

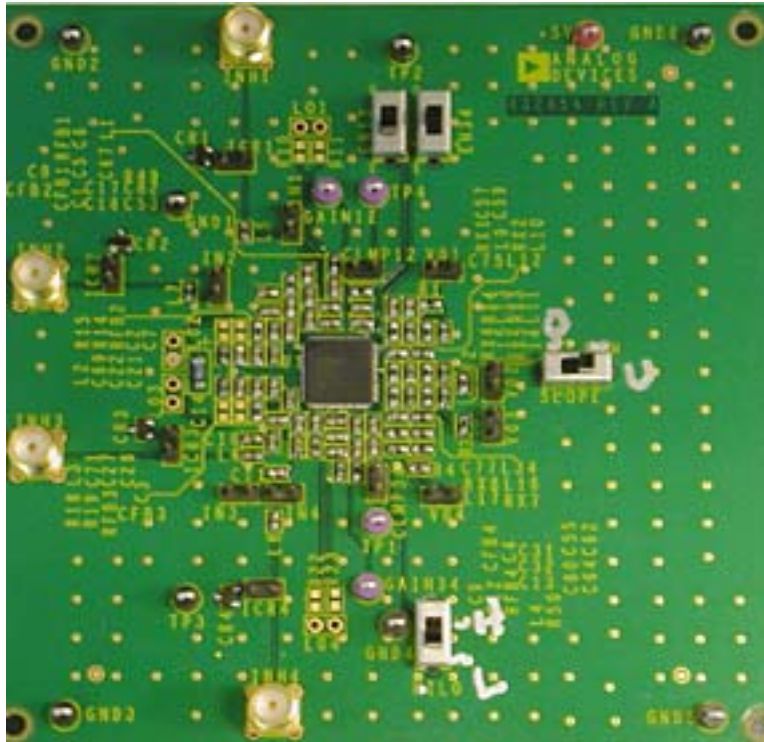

Figure 113. AD8334-EVALZ Top View

03199-122

AD8331/AD8332/AD8334

CONFIGURING THE INPUT IMPEDANCE

The board is built and tested using the components shown in black in Figure 115. Provisions are made for optional components (shown in gray) that can be installed at user discretion. As shipped, the input impedances of the low noise amplifiers (LNAs) are configured for 50 Ω to match the output impedances of most signal generators and network analyzers. Input impedances up to 6 kΩ can be realized by changing the values of the feedback resistors, R_{FB1}, R_{FB2}, R_{FB3}, R_{FB4}, and shunt capacitors, C6, C8, C10, and C12. For reference, Table 12 lists standard values of 1% resistors for some typical values of input impedance. Of course, if the user has determined that the source impedance falls between these values, the feedback resistor value can be calculated accordingly. Note that the board is designed to accept standard surface-mount, size 0603 components.

Table 12. LNA External Component Values for Common Source Impedances

R _{IN} (Ω)	RFB1, RFB2, RFB3, RFB4 (Ω, ±1%)	C6, C8, C10, C12 (pF)
50	274	22
75	412	12
100	562	8
200	1.13 k	1.2
500	3.01 k	No capacitor
6 k	No resistor	No capacitor

Driving the VGA from an External Source or Using the LNA to Drive an External Load

Appropriate components can be installed if the user wants to drive the VGA directly from an external source or to evaluate the LNA output. If the LNA is used to drive off-board loads or cables, small value series resistors (47 Ω to 100 Ω) are recommended for LNA decoupling. These can be installed in the R10, R11, R14, R15, R18, R19, R22, and R23 spaces.

Provisions are made for surface-mount SMA connectors that can be used for driving from either direction. If the LNA is not used, it is recommended that the capacitors, C16, C17, C21, C22, C26, C27, C31, and C32, be carefully removed to avoid driving the outputs of the LNAs.

Using the Clamp Circuit

The board is shipped with no resistors installed in the spaces provided for clamp-circuit operation. Note that each pair of channels shares a clamp resistor. If the output clamping is desired, the resistors are installed in R49 and R50. The peak-to-peak clamping level is application dependent.

Viewing Signals

The preferred signal detector is a high impedance differential probe, such as the Tektronix P6247, 1 GHz differential probe, connected to the 2-pin headers (VO1, VO2, VO3, or VO4), as shown in Figure 116. The low capacitance of this probe has the least effect on the performance of the device of any detection method tried. The probe can also be used for monitoring input signals at IN1, IN2, IN3, or IN4. It can be used for probing other circuit nodes; however, be aware that the 200 kΩ input impedance can affect certain circuits.

Differential-to-single-ended transformers are provided for single-ended output connections. Note that series resistors are provided to protect against accidental output overload should a 50 Ω load be connected to the connector. Of course, the effect of these resistors is to limit the bandwidth. If the load connected to the SMA is >500 Ω, the 237 Ω series resistors, RX1, RX2, RX3, RX4, RX5, RX6, RX7, and RX8, can be replaced with 0 Ω values.

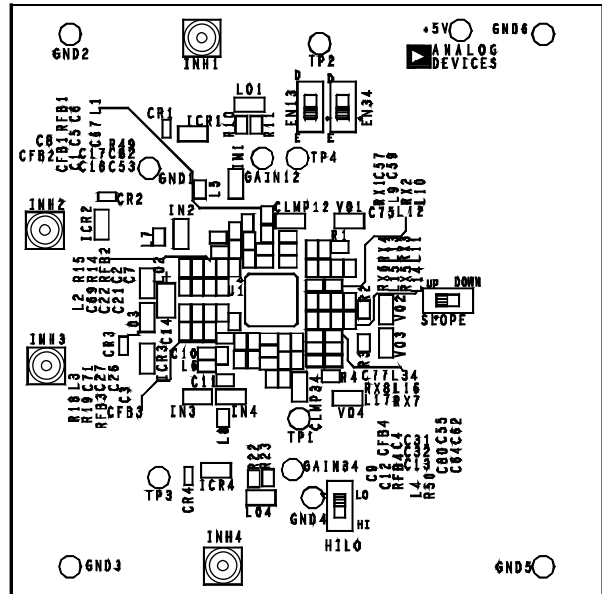

Figure 114. AD8334-EVALZ Assembly

MEASUREMENT SETUP

The basic board connections for measuring bandwidth are shown in Figure 116. A 5 V, 200 mA (minimum) power supply is required, and a low noise voltage reference supply is required for VGAIN.

BOARD LAYOUT

The evaluation board circuitry uses four conductor layers. The two inner layers are ground, and all interconnecting circuitry is located on the outer layers. Figure 117 to Figure 120 illustrate the copper patterns.

EVALUATION BOARD SCHEMATICS

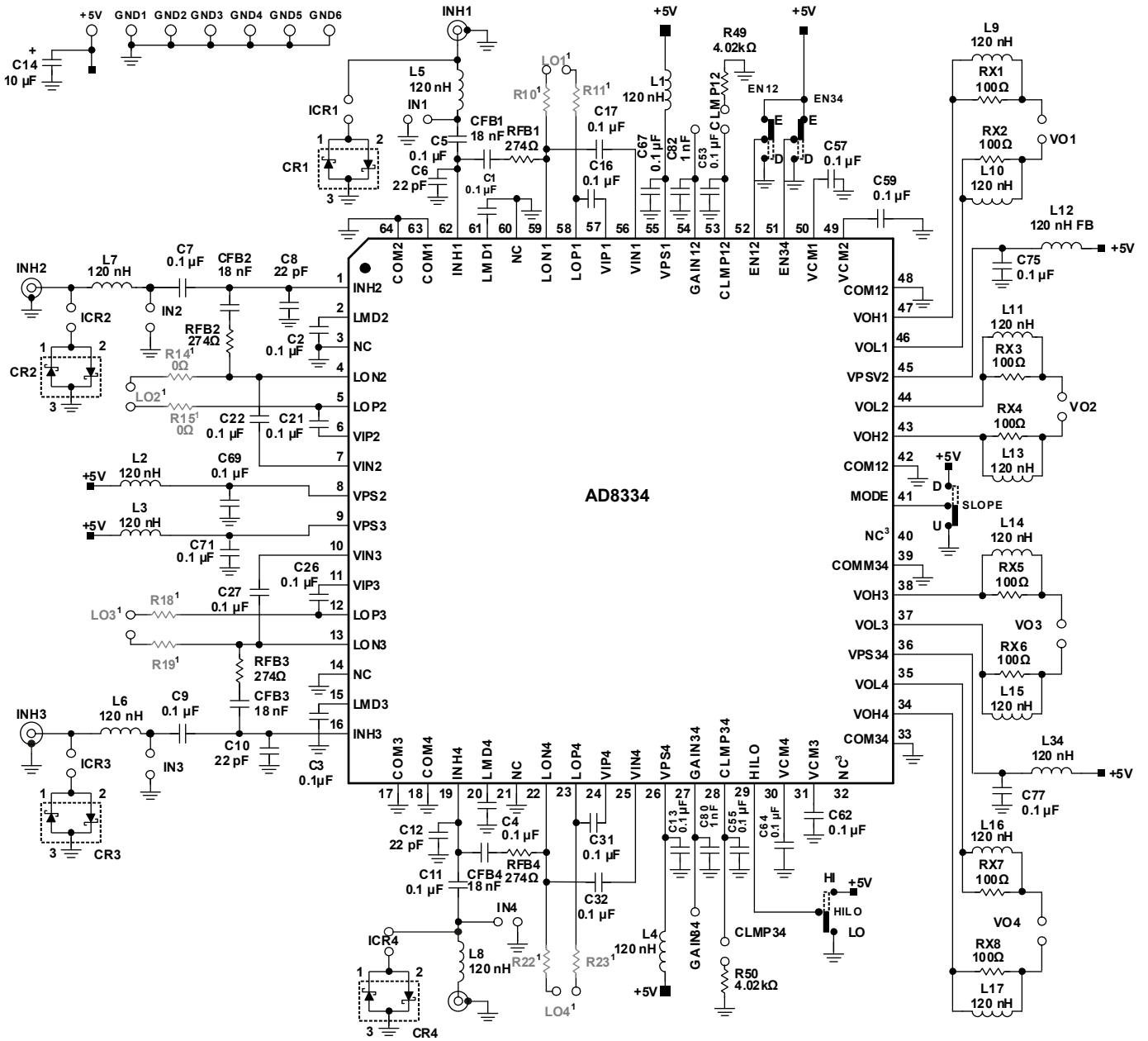

NOTES

- 1 COMPONENTS IN GRAY ARE OPTIONAL USER SUPPLIED.
- 2 NC = NO CONNECT.

Figure 115. AD8334-EVALZ Schematic

AD8331/AD8332/AD8334

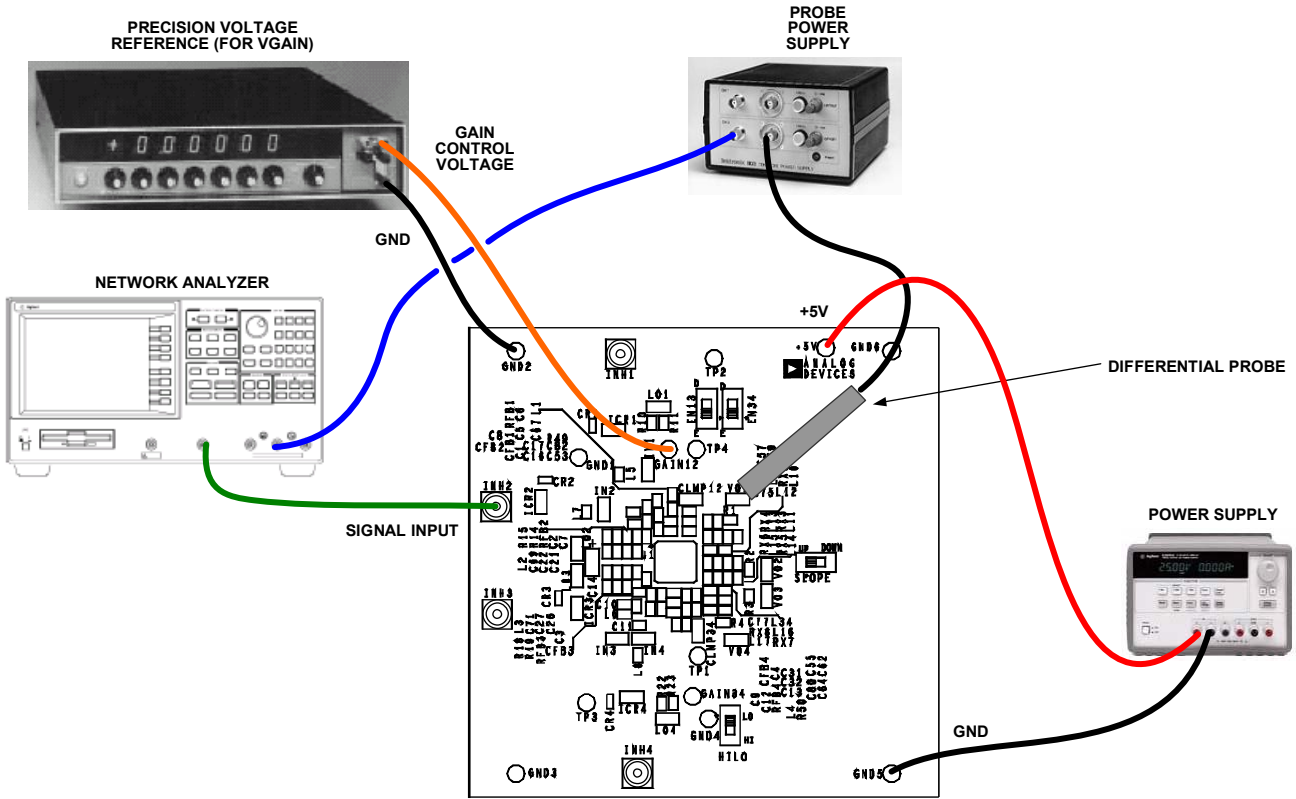

Figure 116. AD8334 Typical Board Test Connections (One Channel Shown)

03199-125

AD8334 EVALUATION BOARD PCB LAYERS

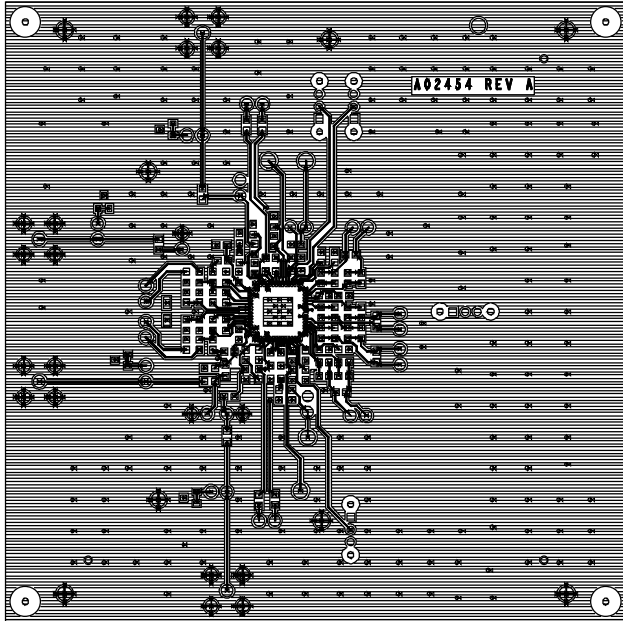

Figure 117. AD8334-EVALZ Primary Side Copper

03199-126

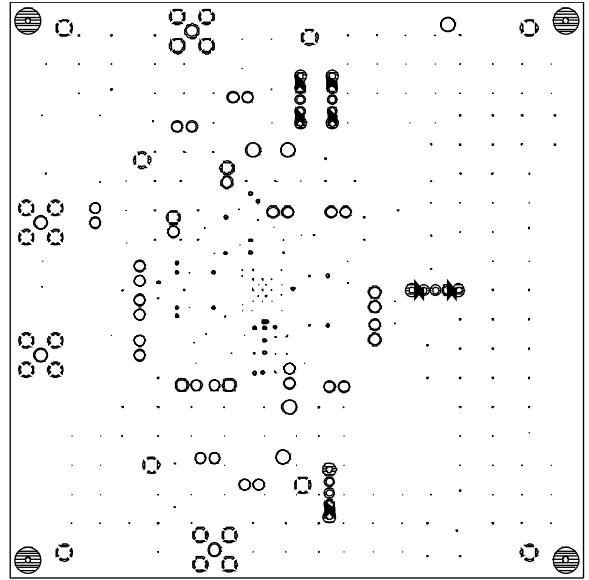

Figure 119. AD8334-EVALZ Inner Layer 1 Copper

03199-128

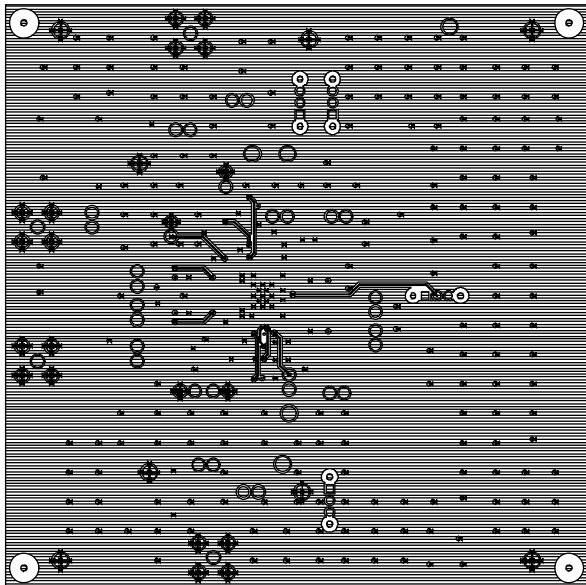

Figure 118. AD8334-EVALZ Secondary Side Copper

03199-127

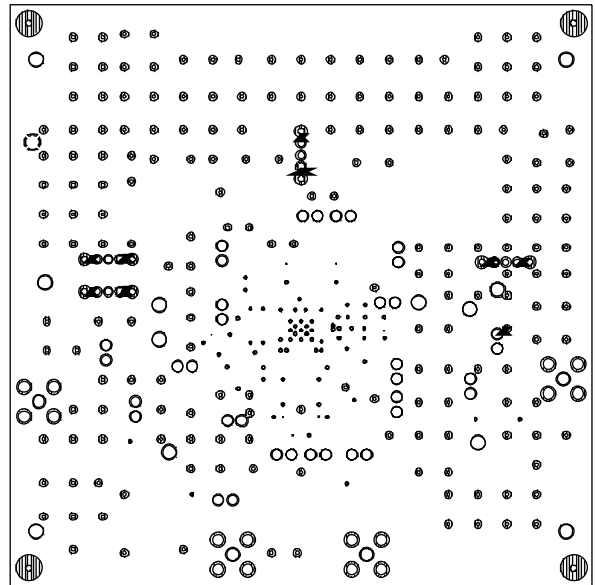

Figure 120. AD8334-EVALZ Inner Layer 2 Copper

03199-129

AD8331/AD8332/AD8334

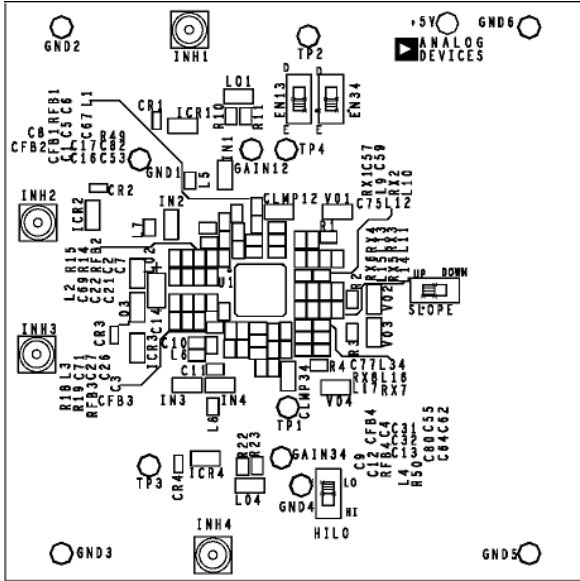
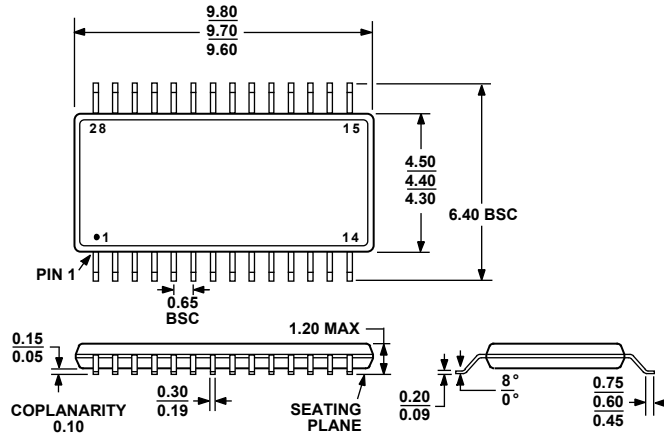

Figure 121. AD8334-EVALZ Component Side Silkscreen

03195-130

OUTLINE DIMENSIONS



COMPLIANT TO JEDEC STANDARDS MO-153-AE

Figure 122. 28-Lead Thin Shrink Small Outline Package (TSSOP) (RU-28)

Dimensions shown in millimeters

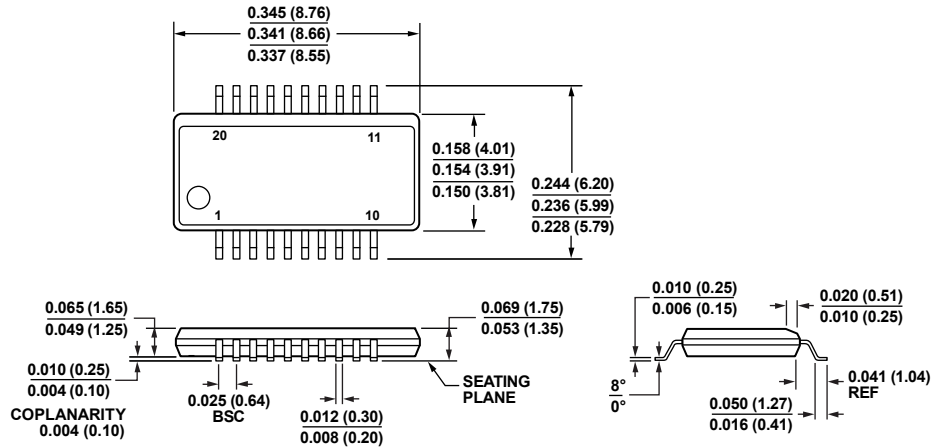

COMPLIANT TO JEDEC STANDARDS MO-137-AD

CONTROLLING DIMENSIONS ARE IN INCHES; MILLIMETERS DIMENSIONS (IN PARENTHESES) ARE ROUNDED-OFF INCH EQUIVALENTS FOR REFERENCE ONLY AND ARE NOT APPROPRIATE FOR USE IN DESIGN.

Figure 123. 20-Lead Shrink Small Outline Package (QSOP) (RQ-20)

Dimensions shown in Inches and (millimeters)

081908-A

AD8331/AD8332/AD8334

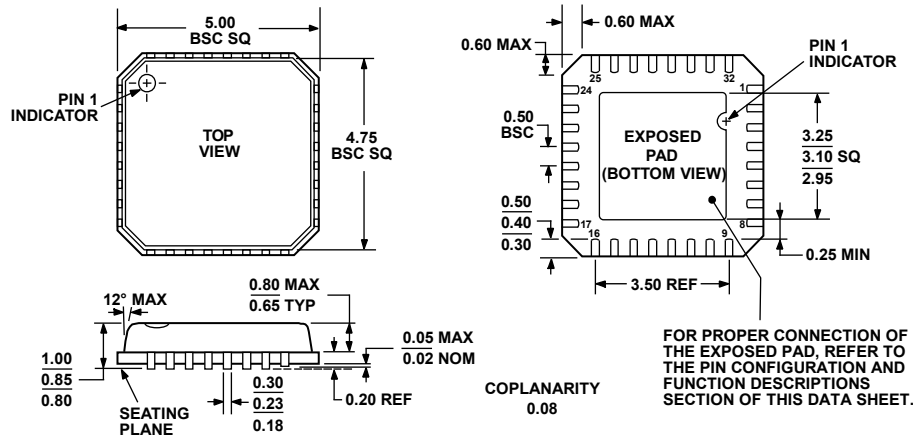

COMPLIANT TO JEDEC STANDARDS MO-220-VHHD-2

Figure 124. 32-Lead Lead Frame Chip Scale Package (LFCSP_VQ)
5 mm × 5 mm Body, Very Thin Quad
(CP-32-2)

Dimensions shown in millimeters

011708-A

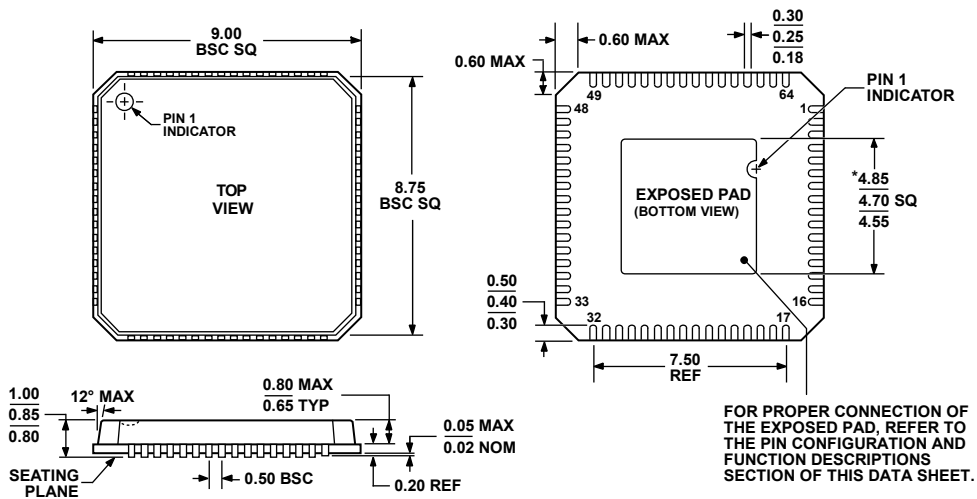

*COMPLIANT TO JEDEC STANDARDS MO-220-VMM4-4
EXCEPT FOR EXPOSED PAD DIMENSION

Figure 125. 64-Lead Lead Frame Chip Scale Package (LFCSP_VQ)
9 mm × 9 mm Body, Very Thin Quad
(CP-64-1)

Dimensions shown in millimeters

002908-B

ORDERING GUIDE

Model¹	Temperature Range	Package Description	Package Option
AD8331ARQ	-40°C to +85°C	20-Lead Shrink Small Outline Package (QSOP)	RQ-20
AD8331ARQ-REEL	-40°C to +85°C	20-Lead Shrink Small Outline Package (QSOP)	RQ-20
AD8331ARQ-REEL7	-40°C to +85°C	20-Lead Shrink Small Outline Package (QSOP)	RQ-20
AD8331ARQZ	-40°C to +85°C	20-Lead Shrink Small Outline Package (QSOP)	RQ-20
AD8331ARQZ-RL	-40°C to +85°C	20-Lead Shrink Small Outline Package (QSOP)	RQ-20
AD8331ARQZ-R7	-40°C to +85°C	20-Lead Shrink Small Outline Package (QSOP)	RQ-20
AD8331-EVALZ		Evaluation Board with AD8331ARQ	
AD8332ACP-R2	-40°C to +85°C	32-Lead Lead Frame Chip Scale Package (LFCSP_VQ)	CP-32-2
AD8332ACP-REEL	-40°C to +85°C	32-Lead Lead Frame Chip Scale Package (LFCSP_VQ)	CP-32-2
AD8332ACP-REEL7	-40°C to +85°C	32-Lead Lead Frame Chip Scale Package (LFCSP_VQ)	CP-32-2
AD8332ACPZ-R2	-40°C to +85°C	32-Lead Lead Frame Chip Scale Package (LFCSP_VQ)	CP-32-2
AD8332ACPZ-R7	-40°C to +85°C	32-Lead Lead Frame Chip Scale Package (LFCSP_VQ)	CP-32-2
AD8332ACPZ-RL	-40°C to +85°C	32-Lead Lead Frame Chip Scale Package (LFCSP_VQ)	CP-32-2
AD8332ARU	-40°C to +85°C	28-Lead Thin Shrink Small Outline Package (TSSOP)	RU-28
AD8332ARU-REEL	-40°C to +85°C	28-Lead Thin Shrink Small Outline Package (TSSOP)	RU-28
AD8332ARU-REEL7	-40°C to +85°C	28-Lead Thin Shrink Small Outline Package (TSSOP)	RU-28
AD8332ARUZ	-40°C to +85°C	28-Lead Thin Shrink Small Outline Package (TSSOP)	RU-28
AD8332ARUZ-R7	-40°C to +85°C	28-Lead Thin Shrink Small Outline Package (TSSOP)	RU-28
AD8332ARUZ-RL	-40°C to +85°C	28-Lead Thin Shrink Small Outline Package (TSSOP)	RU-28
AD8332-EVALZ		Evaluation Board with AD8332ARU	
AD8334ACPZ	-40°C to +85°C	64-Lead Lead Frame Chip Scale Package (LFCSP_VQ)	CP-64-1
AD8334ACPZ-REEL	-40°C to +85°C	64-Lead Lead Frame Chip Scale Package (LFCSP_VQ)	CP-64-1
AD8334ACPZ-REEL7	-40°C to +85°C	64-Lead Lead Frame Chip Scale Package (LFCSP_VQ)	CP-64-1
AD8334-EVALZ		Evaluation Board with AD8334ACP	

¹ Z = RoHS Compliant Part.

NOTES