

EVALUATION KIT
AVAILABLE

Analog CATV Transimpedance Amplifier

General Description

The MAX3660 high-linearity analog RF transimpedance amplifier (TIA) is intended for passive optical network (PON) video receiver applications. With 66dBΩ maximum variable gain and integrated up-tilt, the MAX3660 provides 23dBmV/channel ± 1 dB at 870MHz (19dBmV/channel at 47MHz) for optical inputs between +2dBm to -8dBm (at 4.2% OMI) using simple feed-forward automatic gain control (AGC). It can also be configured with feedback AGC for even greater dynamic range. CNR is better than 48dB from 47MHz to 870MHz (1.0A/W photodiode and -165dB/Hz RIN) at -8dBm with 4.2% OMI, or -6dBm with 3.3% OMI. CSO and CTB are better than -61dBc and -65dBc, respectively. The device supports extended frequency operation to > 1000MHz.

The very low true-TIA input impedance accommodates a variety of photodiodes, eliminating the need for an input matching network and improving yield.

Applications

FTTH Optical Network Termination (ONT)

Typical Application Circuit appears at end of data sheet.

Features

- ◆ Pin Compatible with MAX3654
- ◆ Operates to > 1000MHz
- ◆ 23dBmV/ch Output at 870MHz
- ◆ 4.5pA/Hz^{1/2} Amplifier EIN without Photodiode
- ◆ 58dBm OIP2
- ◆ 24dBm OIP3
- ◆ No Input Matching Required
- ◆ Single +5V Supply
- ◆ 650mW Dissipation
- ◆ -40°C to +85°C Operating Temperature Range

Ordering Information

PART	TEMP RANGE	PIN-PACKAGE
MAX3660ETE+	-40°C to +85°C	16 TQFN-EP*

+Denotes a lead-free/RoHS-compliant package.

*EP = Exposed pad.

Pin Configuration

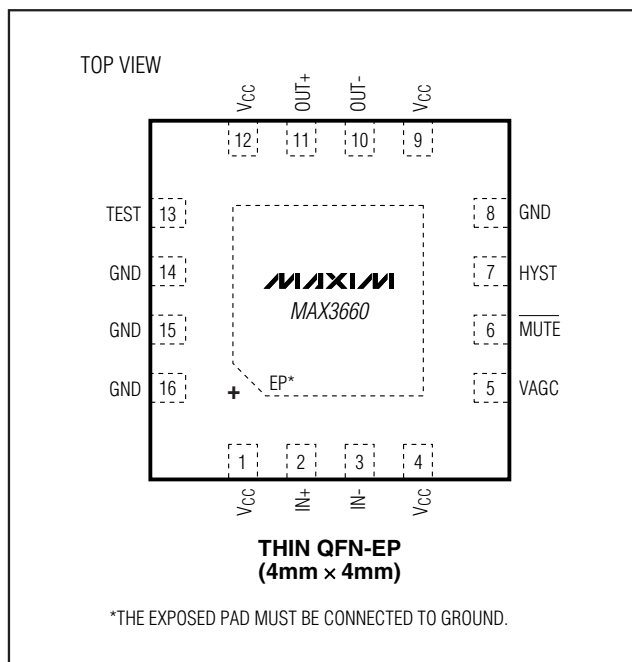

MAX3660

Analog CATV Transimpedance Amplifier

ABSOLUTE MAXIMUM RATINGS

Supply Voltage Range, V_{CC}-0.3V to +5.5V
 $IN+$, $IN-$, V_{AGC} , \overline{MUTE} ,
 \overline{HYST} , $TEST$($V_{EE} - 0.4V$) to ($V_{CC} + 0.4V$)
 Output Current ($OUT+$, $OUT-$)60mA
 Maximum Voltage ($OUT+$, $OUT-$).....($V_{CC} + 0.4V$)

Continuous Power Dissipation ($T_A = +70^\circ C$)
 16-Pin TQFN-EP (derate 16.9mW/ $^\circ C$ above $+70^\circ C$)..1349mW
 Operating Temperature Range-40 $^\circ C$ to +85 $^\circ C$
 Storage Temperature Range.....-55 $^\circ C$ to +175 $^\circ C$
 Lead Temperature (soldering, 10s).....+300 $^\circ C$

Stresses beyond those listed under "Absolute Maximum Ratings" may cause permanent damage to the device. These are stress ratings only, and functional operation of the device at these or any other conditions beyond those indicated in the operational sections of the specifications is not implied. Exposure to absolute maximum rating conditions for extended periods may affect device reliability.

DC ELECTRICAL CHARACTERISTICS

($V_{CC} = +4.75V$ to $+5.25V$, $T_A = -40^\circ C$ to $+85^\circ C$. Typical values are at $V_{CC} = +5V$, $T_A = +25^\circ C$, unless otherwise noted.) (Note 1)

PARAMETER	SYMBOL	CONDITIONS	MIN	TYP	MAX	UNITS
Supply Current	I_{CC}			130	180	mA
Gain Control Input Current	I_{VAGC}	$V_{VAGC} = 1.4V$		-15	-200	μA
\overline{MUTE} Input High	V_{IH}		2.0			V
\overline{MUTE} Input Low	V_{IL}				0.5	V
\overline{MUTE} Input Current	I_{IL} , I_{IH}	$V_{\overline{MUTE}} = 0.5V, 2.0V$			± 30	μA

AC ELECTRICAL CHARACTERISTICS

($V_{CC} = +4.75V$ to $+5.25V$, $T_A = -40^\circ C$ to $+85^\circ C$, output $Z_L = 75\Omega$, unless otherwise noted. Typical values are at $V_{CC} = +5V$, $T_A = +25^\circ C$, unless otherwise noted.)

PARAMETER	SYMBOL	CONDITIONS	MIN	TYP	MAX	UNITS
Frequency Response Flatness (Notes 2, 3, 4)		47MHz to 870MHz			± 0.9	dB
		47MHz to 1000MHz			± 1.0	
Transimpedance, Differential	ZT	47MHz, $V_{VAGC} = 0V$		66		dB Ω
		47MHz, $V_{VAGC} = 0.175V$ (Note 2)	63.5	66	67.5	
		47MHz, $V_{VAGC} = 0.5V$ (Note 2)	54	56.5	58	
		47MHz, $V_{VAGC} = 1.4V$ (Note 2)	45.5	48	49.5	
		47MHz, $V_{VAGC} = 1.6V$		46.5		
Gain Tilt		Linear, 870MHz vs. 47MHz (Note 4)	3.8	4.5	5.0	dB
Gain Control Stability		$0.175V \leq V_{VAGC} \leq 1.4V$, $R_{HYST} = \text{open}$ (Notes 2, 5)		± 0.8	± 2.0	dB
Output Second-Order Intercept	OIP2	47MHz to 870MHz, $0.175V \leq V_{VAGC} \leq 1.4V$ (Note 6)		58		dBm
Output Third-Order Intercept	OIP3	47MHz to 870MHz, $0.175V \leq V_{VAGC} \leq 1.4V$ (Note 6)	20	24		dBm

Analog CATV Transimpedance Amplifier

AC ELECTRICAL CHARACTERISTICS (continued)

($V_{CC} = +4.75V$ to $+5.25V$, $T_A = -40^{\circ}C$ to $+85^{\circ}C$, output $Z_L = 75\Omega$, unless otherwise noted. Typical values are at $V_{CC} = +5V$, $T_A = +25^{\circ}C$, unless otherwise noted.)

PARAMETER	SYMBOL	CONDITIONS	MIN	TYP	MAX	UNITS
Equivalent Input Noise, Including Photodiode	EIN	47MHz to 870MHz, $0.175V \leq V_{VAGC} \leq 1.4V$ (Notes 2, 4)		5.5	7.3	$\mu A/Hz^{1/2}$
Gain Control Hysteresis (Notes 1, 7)		R _{HYST} = open		± 0.14		dB (optical)
		R _{HYST} = GND		± 0.75		
Transimpedance, Mute		$V_{MUTE} \leq 0.8V$, 47MHz			20	$dB\Omega$
RF Output Return Loss	-S22	47MHz to 870MHz (Notes 4, 8)		20		dB

Note 1: DC parameters are tested at $T_A = +25^{\circ}C$ and $+85^{\circ}C$.

Note 2: Guaranteed by design and characterization.

Note 3: Frequency response flatness is the maximum difference between the frequency response at any point and a line connecting the end points of 47MHz and 870MHz.

Note 4: Measured using the MAX3660 EV kit circuit in Figure 4 with an Excelight SXT5241-Q/GPA triplexer (8mm photodiode lead length).

Note 5: Gain control stability is the maximum variation in transimpedance (over process, voltage, and temperature) for any valid VAGC voltage.

Note 6: OIP2 and OIP3 values are tested with tones at 800MHz and 850MHz.

Note 7: Hysteresis is referred to optical gain, equivalent to two times electrical gain (dB).

Note 8: Not including balun.

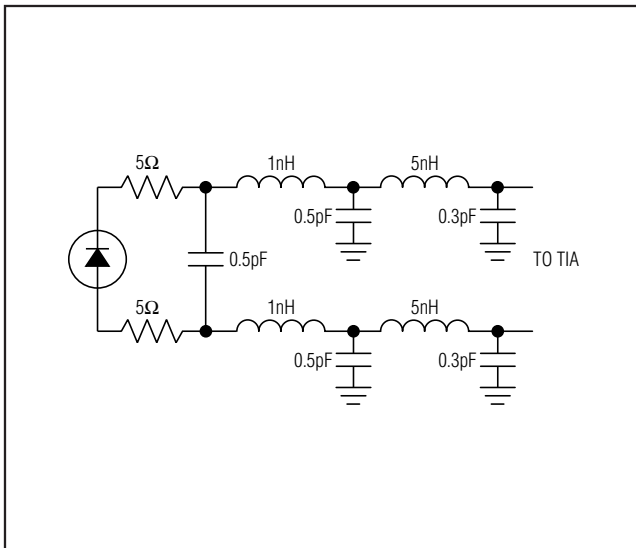

Figure 1. Photodiode and Header Model

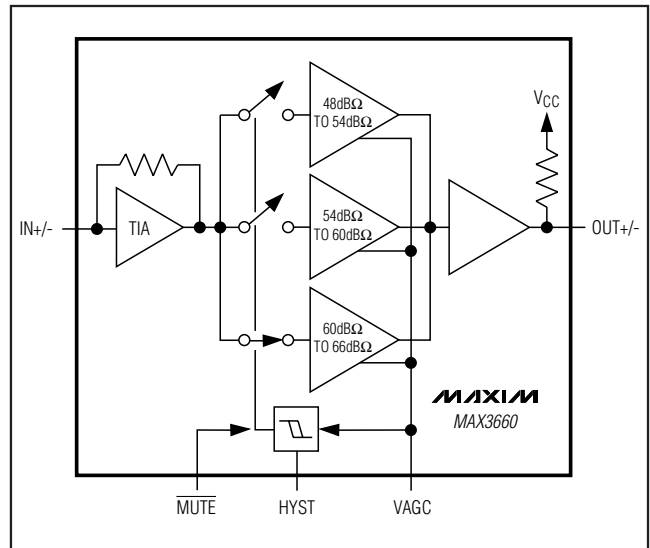

Figure 2. Functional Diagram

Analog CATV Transimpedance Amplifier

Typical Operating Characteristics

($V_{CC} = +5.0V$, $T_A = +25^\circ C$, unless otherwise noted. CNR, CSO, and CTB are for the MAX3660 EV Kit at $P_{IN} = -8dBm$, with channels above 350MHz attenuated 6dB.)

GAIN (ZT) vs. FREQUENCY

($V_{VAGC} = 0.10V, 0.175V, 0.25V, 0.35V, 0.7V, 1.05V, 1.4V, 1.6V$; $T_A = -40^\circ C, +25^\circ C, +85^\circ C$)

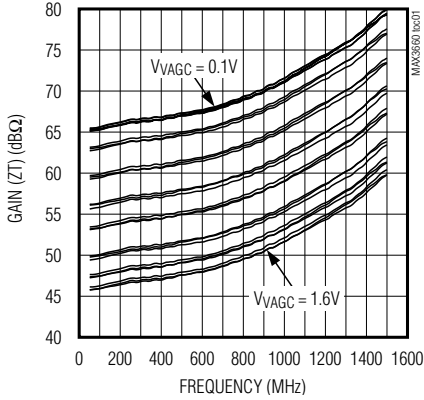

GAIN (ZT) vs. VAGC

($T_A = -40^\circ C, +25^\circ C, +85^\circ C$)

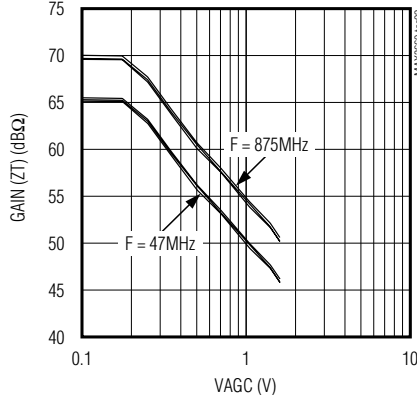

DEVIATION FROM LINEAR TILT vs. FREQUENCY

($V_{VAGC} = 0$ TO 1.6V; $T_A = -40^\circ C, +25^\circ C, +85^\circ C$)

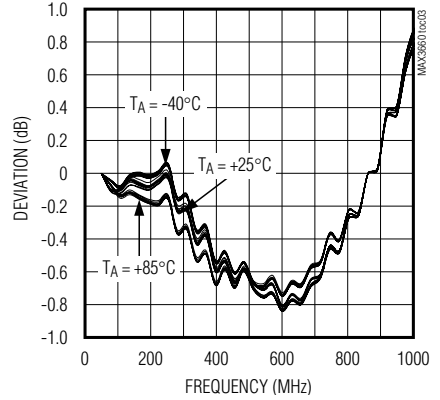

DEVIATION FROM IDEAL GAIN vs. VAGC

(FREQUENCY = 47MHz, $T_A = -40^\circ C, +25^\circ C, +85^\circ C$)

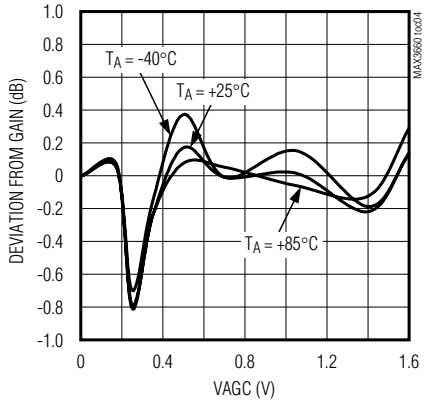

OIP2, OIP3 vs. VAGC

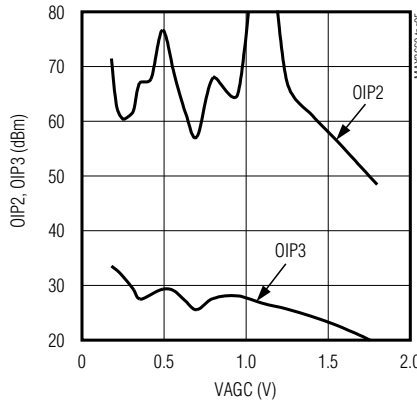

EQUIVALENT INPUT NOISE vs. FREQUENCY

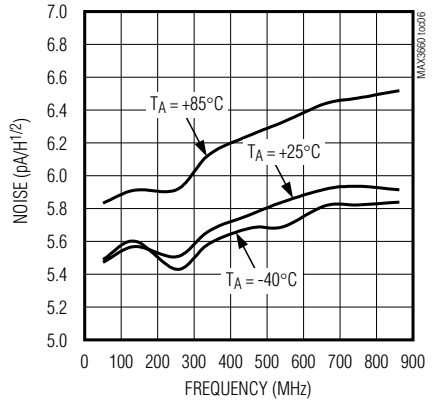

CNR vs. FREQUENCY

(110 CHANNELS, OMI = 4.2%/2.1%)

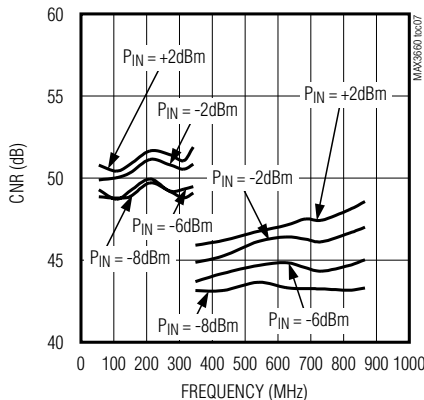

CSO, CTB vs. FREQUENCY

(110 CHANNELS, $P_{IN} = +2dBm$, OMI = 4.2%/2.1%)

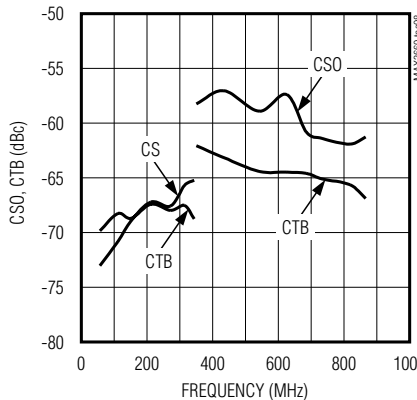

S22 NORMALIZED TO 75Ω

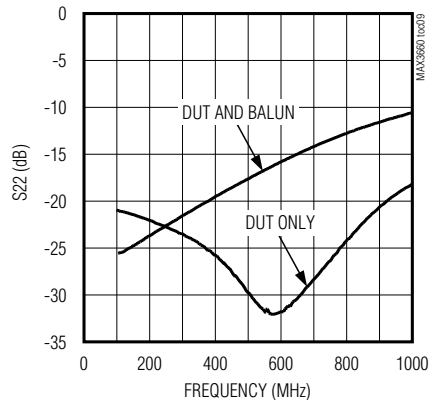

Analog CATV Transimpedance Amplifier

Pin Description

MAX3660

PIN	NAME	FUNCTION
1, 4, 9, 12	VCC	+5.0V Supply
2	IN+	Positive Analog Input. Connect to photodiode cathode.
3	IN-	Negative Analog Input. Connect to photodiode anode.
5	VAGC	AGC Control Input. See the Gain (ZT) vs. Frequency graph.
6	MUTE	Active-Low Mute Control Input. $V_{MUTE} < 0.8V$ to disable output.
7	HYST	AGC Hysteresis Control Input. A resistor from HYST to GND controls the hysteresis level.
8, 14, 15, 16	GND	Supply Ground
10	OUT-	Negative RF Output
11	OUT+	Positive RF Output
13	TEST	Reserved for test. Connect to GND for normal operation.
—	EP	Exposed Pad. The exposed pad must be soldered to the circuit board ground for proper thermal and electrical performance.

Detailed Description

The MAX3660 variable gain TIA has differential AC-coupled photocurrent inputs and 75Ω differential RF output. When used with a low-cost operational amplifier, photodiode assembly, bias network, and balun, the MAX3660 provides a complete high-performance BPON/GPON video receiver with a simple and effective feed-forward AGC. It can also be used with feedback AGC.

Low-Noise Variable-Gain Amplifier

The low-noise differential input is designed to be AC-coupled to the anode and cathode of the analog photodiode in a PON triplexer. The maximum input current to achieve rated linearity is 1.675mA_{P-P} .

Very low TIA input impedance provides excellent frequency response with no (internal or external) compensation between photodiode and amplifier, thus simplifying design, manufacturing, and photodiode selection.

VAGC and Hysteresis Control

The overall transimpedance is controlled using the VAGC input pin. See the *Typical Operating Characteristics* for descriptions of the transimpedance, OIP2 (CSO), and OIP3 (CTB) performance for VAGC voltages between 0 and 1.8V.

The MAX3660 has a very flat and stable gain vs. voltage characteristic in the range $0.175V \leq V_{VAGC} \leq 1.4V$, enabling a simple feed-forward AGC based on average

optical power level as measured by the photodiode DC current (see Figure 4 for the EV kit schematic).

Feedback AGC can be used to achieve a wider dynamic range, in which case the VAGC voltage would be controlled by an external power detector, such as the MAX2014, typically through a microcontroller interface. In this case, the maximum voltage at VAGC should be kept below approximately 1.65V to maintain adequate linearity levels for typical GPON applications.

The forward signal path is implemented with three switched variable gain stages, each covering one-third of the total dynamic range. When the voltage input at VAGC crosses the points on the Gain (ZT) vs. VAGC curve where a new stage is selected ($V_{VAGC} = 350\text{mV}$ and $V_{VAGC} = 700\text{mV}$), there can be a small (approximately 50ns) deviation in the output, causing an interruption to the CATV signal. Hysteresis is provided for the VAGC input to prevent the output signal from dithering when the average optical input level is very close to one of these two switching points. The amount of hysteresis can be controlled by the value of R_{HYST} , and is minimum (0.14dB) when R_{HYST} is open.

RF Output and Cable Tilt Compensation

The MAX3660 includes integrated cable compensation (uptilt). With a photodiode assembly similar to that described in Figure 1, the output at 870MHz is 4dB higher compared to the output at 47MHz. About half of the uptilt is due to the combination of photodiode capacitance and the inductance of the triplexer leads, and half is internal to the MAX3660.

Analog CATV Transimpedance Amplifier

RF Output and Input Stage

The differential outputs should be connected to a balun transformer to produce a single-ended 75Ω output. If the MAX3660 is used to drive a single-ended postamplifier, the use of a balun is recommended (refer to Maxim Reference Design HFRD-22.4) to achieve adequate linearity and noise performance. With a typical low-cost balun, output return loss (-S22) is better than 15dB up to 550MHz and is limited by the balun performance.

When $\overline{\text{MUTE}}$ is logic-low, the transimpedance is less than $20\text{dB}\Omega$.

Applications Information

Photodiode/TIA Interface

The MAX3660 is designed to provide a $23\text{dBmV}/\text{channel}$ output at 870MHz with excellent CSO, CTB, and CNR, and its frequency response extends well beyond 1000MHz.

The RF output has $4\text{dB} \pm 1\text{dB}$ of up tilt and $\pm 0.9\text{dB}$ of flatness (47MHz to 870MHz) when used with a photodiode and assembly having characteristics similar to those shown in Figure 1, which is consistent with a typical low-cost FTTH triplexer connected by 5mm leads to matched vias. The MAX3660's very low input impedance (approximately 10Ω) also provides tolerance to variations in photodiode and assembly electrical characteristics.

It is particularly important to provide electrical symmetry in the anode and cathode connections, including the triplexer/ROSA lead routing and PCB mounting configuration. Consult the EV kit and Maxim reference designs for examples of good layout techniques. With typical optical transmitter characteristics, the MAX3660 achieves CSO and CTB better than -65dBc and achieves CNR (including amplifier noise, photodiode shot noise, and transmitter RIN) of 48dB (at -6dBm or greater with $\text{OMI} = 3.3\%$, or at -8dBm or greater with $\text{OMI} = 4.2\%$) between 47MHz and 870MHz. Refer to the MAX3660 EV kit data sheet for a description of the setup used for CSO, CTB, and CNR typical operating characteristics measurements.

To achieve optimum CNR performance, the AGC should be configured so that the MAX3660's gain is greatest ($V_{\text{VAGC}} \leq 0.175\text{V}$) at the lowest intended optical input level, typically -6dBm or -8dBm . To maintain CTB and CSO performance, care should also be exercised when designing the AGC so that the maximum operating VAGC level is limited to approximately 1.6V. Operating

with input signal levels greater than $1.6\text{mA}_{\text{P-P}}$ can result in a reduction in linearity due to clipping.

Photodiode Bias Network

A combination of resistors and inductors, such as shown in Figure 3, provides DC bias to the photodiode. The series connection of two inductors and one resistor is intended to mitigate effects of inductor self-resonance.

The DC voltage drop across the lower resistor provides an effective means to measure average optical power for use as a signal strength indicator and/or feed-forward AGC.

The value of the resistors can be adjusted to vary the feed-forward gain. Depending on the specific photodiode characteristics and desired frequency response, between 5V and 12V should normally be used for V_{PD} .

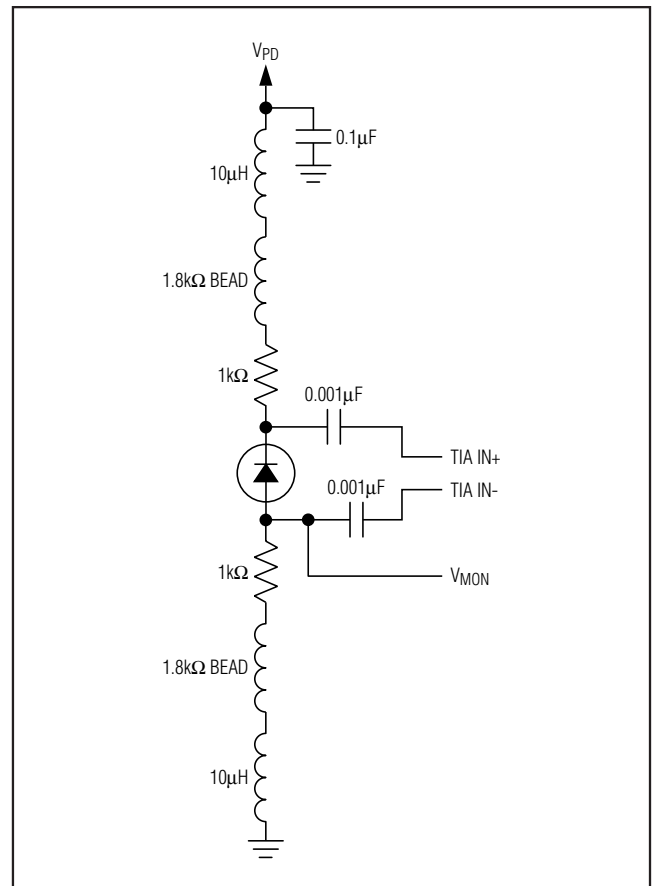

Figure 3. Photodiode Bias Network

Analog CATV Transimpedance Amplifier

Gain vs. VAGC Voltage

The overall transimpedance at 47MHz is related to the voltage at VAGC by the relation:

$$ZT(\text{dB}\Omega) = 66\text{dB}\Omega + 20\log\left[\frac{175\text{mV}}{V_{\text{VAGC}}(\text{mV})}\right], \quad (0.175\text{V} \leq V_{\text{VAGC}} \leq 1.4\text{V})$$

The gain at 870MHz is 4dB greater (70dB Ω at $V_{\text{VAGC}} = 0.175\text{V}$) because of the uptilt, although the amount of uptilt can be modified as described above.

Between 0 and 0.175V the gain is constant, and above 1.5V it falls off relatively quickly. Operation above $V_{\text{VAGC}} = 1.6\text{V}$ should be avoided to obtain adequate linearity performance.

The high-impedance VAGC input should be driven by a source (op amp, DAC, etc.) capable of sinking up to 200 μA .

Feed-Forward AGC

With a feed-forward circuit like that of the EV kit, the MAX3660 provides a constant ($\pm 1\text{dB}$) output of 19dBmV/channel at 47MHz and 23dBmV/channel at 870MHz, for optical input levels ranging between -8dBm and +2dBm at OMI = 4.2%.

Feedback AGC

The VAGC voltage can also be controlled from a power detector, such as the MAX2014 or MAX9933, for feedback AGC.

It is important to note that the Gain (ZT) vs. VAGC characteristic includes hysteresis at the two points where the input stage switches gain (350mV and 700mV), which can cause problems such as limit-cycle oscillation with continuous analog feedback implementations. The feedback circuit should be designed to avoid oscillation or dithering.

Uptilt

The integrated uptilt results in equal input levels producing an output voltage that is 4dB greater at 870MHz compared to 47MHz, eliminating the loss normally associated with an external passive tilt network. The amount of uptilt can be varied by adjusting the triplexer lead length, or by adding small inductors in series with the anode and cathode, to compensate for photodiodes/triplexers that differ significantly from Figure 1.

Equivalent Input Noise

The typical equivalent input referred noise (EIN) of the MAX3660 with a photodiode connected at the input is 5.5pA/Hz^{1/2}, yielding 48dB or better CNR under normal BPON/GPON conditions. Without a photodiode connected, the typical EIN is 4.5pA/Hz^{1/2}.

RF Output

The RF output should be connected to the MAX3660 using AC-coupling capacitors and a balun transformer to achieve the desired noise and linearity performance. Without the capacitors, shorting OUT+ and OUT- together, or shorting OUT+ or OUT- to ground, can draw sufficient current to damage the output stage.

EV Kit Circuit

The MAX3660 EV kit circuit shown in Figure 4 was used to collect the data in the *Typical Operating Characteristics* figures. When connected to a photodiode-equipped triplexer, the EV kit circuit provides a complete receiver, including photodiode bias, feed-forward AGC, and output transformer.

Jumper JU1 controls the $\overline{\text{MUTE}}$ input, JU3 sets the amount of hysteresis, and JU2 controls the input of the op amp driving the VAGC input. Install JU2 to enable feed-forward VAGC, or alternatively, the gain can be controlled by TP6 with JU2 removed.

Analog CATV Transimpedance Amplifier

Typical Application Circuit

MAX3660

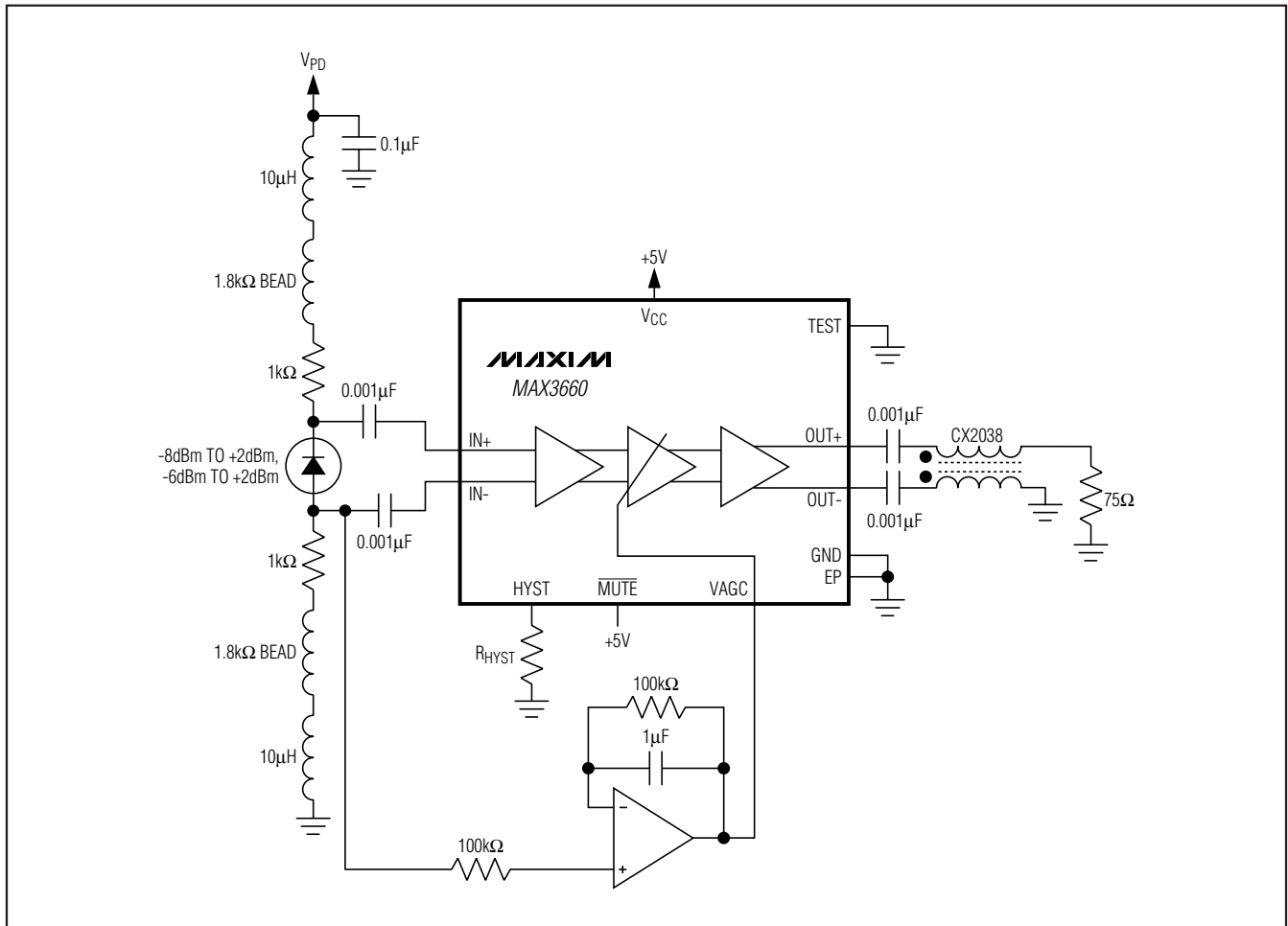

Chip Information

PROCESS: SiGe BiPOLAR
SUBSTRATE: SOI

Package Information

For the latest package outline information and land patterns, go to www.maxim-ic.com/packages.

PACKAGE TYPE	PACKAGE CODE	DOCUMENT NO.
16 TQFN-EP	T1644+3	21-0139

Maxim cannot assume responsibility for use of any circuitry other than circuitry entirely embodied in a Maxim product. No circuit patent licenses are implied. Maxim reserves the right to change the circuitry and specifications without notice at any time.

Maxim Integrated Products, 120 San Gabriel Drive, Sunnyvale, CA 94086 408-737-7600 _____ 9