

## TRUE DIGITAL AUDIO AMPLIFIER TAS5001 DIGITAL AUDIO PWM PROCESSOR

### FEATURES

- TAS5001 + TAS5100 TDAA System – High Quality Digital Audio Amplification
- 96-dB Dynamic Range (TAS5001 Device)
- 93-dB Dynamic Range (TAS5001 and TAS5100 System Measured at Speaker Terminals)
- THD+N < 0.08% (1 kHz, 0 to 30 W RMS Into 6 Ω) (TAS5001 & TAS5100 System Measured at Speaker Terminals)
- Power Efficiency Is 90% Into 8-Ω Load
- 16-, 20-, or 24-Bit Input Data
- 32-kHz, 44.1-kHz, 48-kHz, 88.2-kHz, 96-kHz Sampling Rates
- Economical 48-Pin TQFP Package
- Lower-Jitter Internal PLL
- 3.3-V Power Supply
- Mute
- Clicks and Pops Reduction (Patent Pending)

- Internet Music Appliance
- Mini/Micro Component Systems

### DESCRIPTION

The true digital audio amplifier (TDAA) is a new paradigm in digital audio. One TDAA system consists of the TAS5001 PCM-PWM modulator device + TAS5100 PWM power output device. This system accepts a serial PCM digital audio stream and converts it to a 3.3-V PWM audio stream (TAS5001). The TAS5100 device then provides a large-signal PWM output. This digital PWM signal is then demodulated providing power output for driving loudspeakers. This patented technology provides low-cost, high-quality, high-efficiency digital audio applicable to many audio systems developed for the digital age. The TAS5001 is an innovative, cost-effective, high-performance 24-bit stereo PCM-PWM modulator based on Equibit™ technology. It has a wide variety of serial input options including right-justified (16, 20, or 24 bits), IIS (16, 20, or 24 bits), left-justified (16 bits), or DSP (16 bits) data formats. It is fully compatible with AES standard sampling rates of 32 kHz, 44.1 kHz, 48 kHz, 88.2 kHz, and 96 kHz. The TAS5001 also provides a de-emphasis function for 44.1-kHz and 48-kHz sampling rates.

### APPLICATIONS

- DVD Audio
- Home Theater
- Car Audio Amplifiers and Head Units

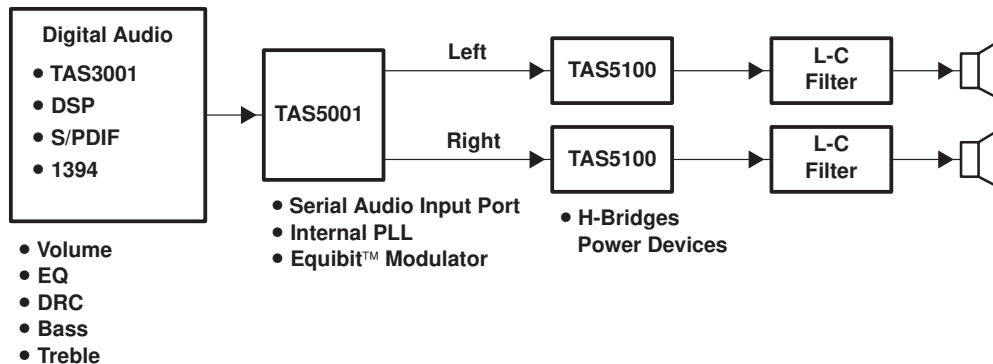

Please be aware that an important notice concerning availability, standard warranty, and use in critical applications of Texas Instruments semiconductor products and disclaimers thereto appears at the end of this data sheet.

Equibit is a trademark of Toccata Technology ApS, Denmark.

PRODUCTION DATA information is current as of publication date. Products conform to specifications per the terms of Texas Instruments standard warranty. Production processing does not necessarily include testing of all parameters.

Copyright © 2001, Texas Instruments Incorporated

## terminal assignments

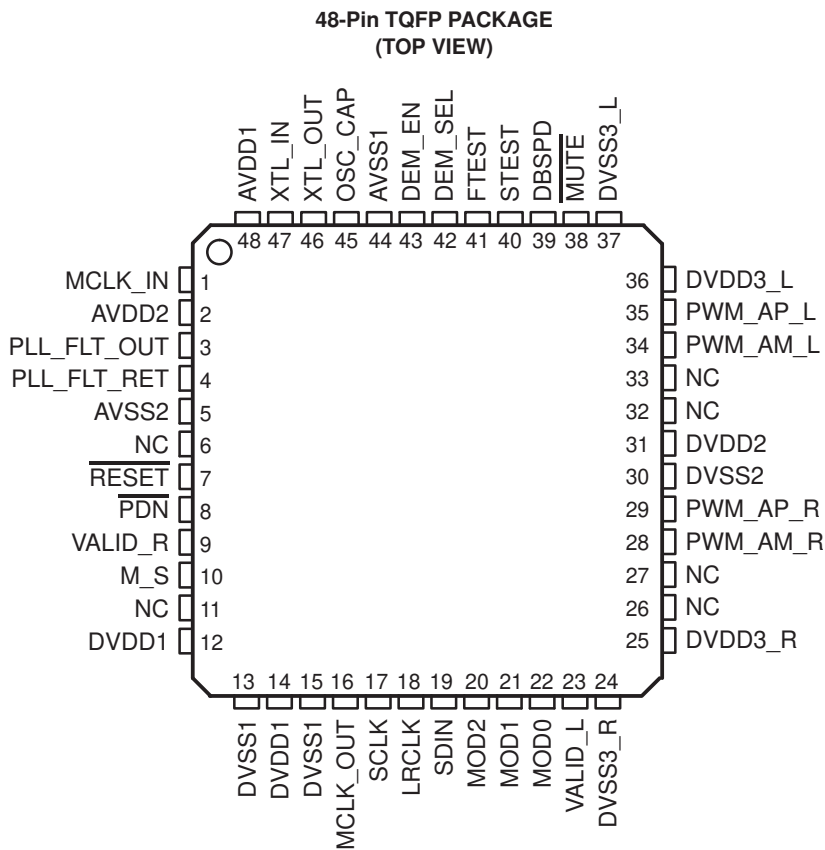

NC – No internal connection

## references

- *True Digital Audio Amplifier TAS5100 PWM Power Output Stage* – Texas Instruments literature number SLLS419A
- *Design Considerations for TAS5000/TAS5100 True Digital Audio Power Amplifiers* – Texas Instruments literature number SLAA117
- *Digital Audio Measurements* – Texas Instruments literature number SLAA114
- *PowerPAD™ Thermally Enhanced Package* – Texas Instruments literature number SLMA002

functional block diagram

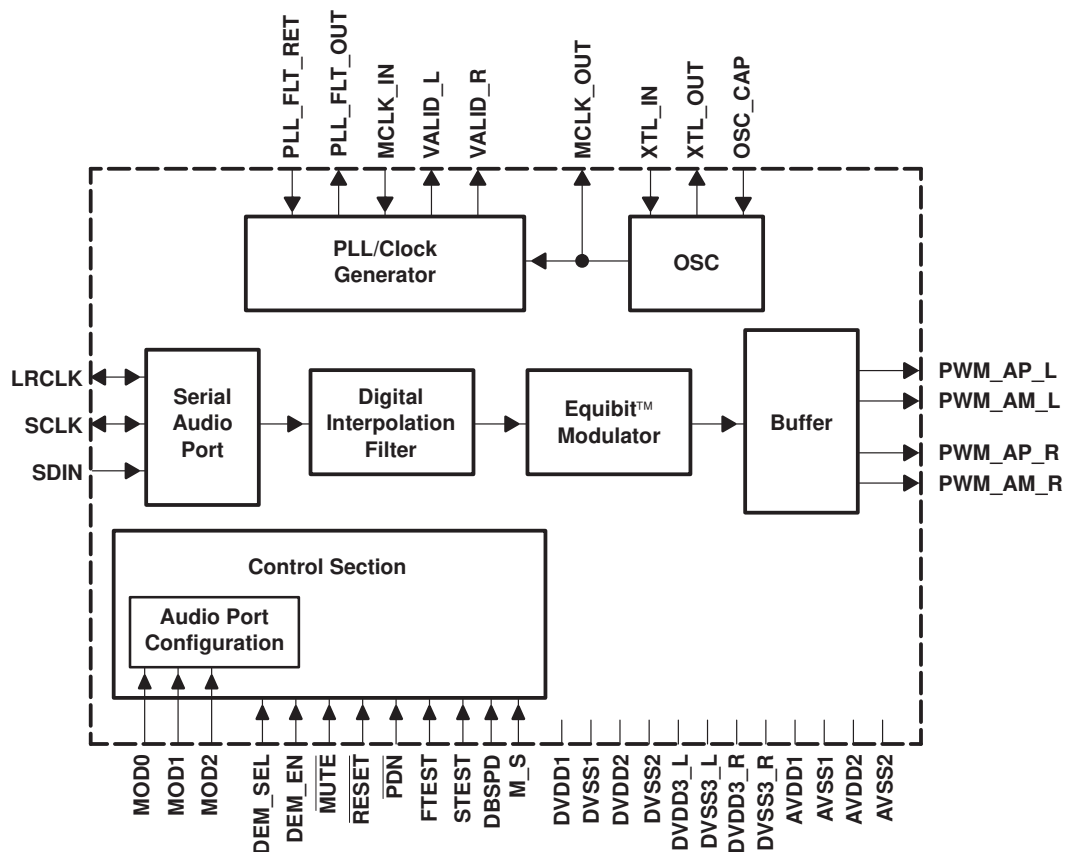

AVAILABLE OPTIONS

T <sub>A</sub>	PACKAGE†
0°C to 70°C	TAS5001PFB
-40°C to 85°C	TAS5001IPFB

† These packages are available taped and reeled. Add an R suffix to device type (e.g., TAS5001PFBR).

## Terminal Functions

TERMINAL NAME	NO.	I/O	DESCRIPTION
AVDD1	48	I	Analog supply for oscillator
AVDD2	2	I	Analog supply for PLL
AVSS1	44	I	Analog ground for oscillator
AVSS2	5	I	Analog ground for PLL
DBSPD	39	I	Indicates sample rate is double speed (88.2 kHz or 96 kHz), active high
DEM_EN	43	I	De-emphasis enable, active high
DEM_SEL	42	I	De-emphasis select (0 = 44.1 kHz, 1 = 48 kHz)
DVDD1	12, 14	I	Digital voltage supply for logic
DVDD2	31	I	Digital voltage supply for PWM reclocking
DVDD3_L	36	I	Digital voltage supply for PWM output (left)
DVDD3_R	25	I	Digital voltage supply for PWM output (right)
DVSS1	13, 15	I	Digital ground for logic
DVSS2	30	I	Digital ground for PWM reclocking
DVSS3_L	37	I	Digital ground for PWM output (left)
DVSS3_R	24	I	Digital ground for PWM output (right)
FTEST	41	I	Tied to DVSS1 for normal operation
LRCLK	18	I/O	Left/right clock (input when M_S = 0; output when M_S = 1)
MCLK_IN	1	I	MCLK input
MCLK_OUT	16	O	Buffered system clock output if M_S = 1; otherwise set to 0
MOD0	22	I	Serial interface selection pin, bit 0
MOD1	21	I	Serial interface selection pin, bit 1
MOD2	20	I	Serial interface selection pin, bit 2 (MSB)
M_S	10	I	Master/slave, master=1, slave=0
MUTE	38	I	Muted signal = 0, normal mode = 1
NC	6, 11, 26, 27, 32, 33		No connection
OSC_CAP	45	I	Oscillator cap return
PDN	8	I	Power down, active low
PLL_FLT_OUT	3	O	Output terminal for external PLL filter
PLL_FLT_RET	4	I	Return for external PLL filter
PWM_AM_L	34	O	PWM left output (differential -)
PWM_AM_R	28	O	PWM right output (differential -)
PWM_AP_L	35	O	PWM left output (differential +)
PWM_AP_R	29	O	PWM right output (differential +)
RESET	7	I	Reset (active low)
SCLK	17	I/O	Shift clock (input when M_S = 0, output when M_S = 1)
SDIN	19	I	Stereo serial audio data input
STEST	40	I	Tied to DVSS1 for normal operation
VALID_L	23	O	PWM left outputs valid (active high)
VALID_R	9	O	PWM right outputs valid (active high)
XTL_IN	47	I	Crystal or clock input (MCLK input)
XTL_OUT	46	O	Crystal output (not for external usage). NC when XTL_IN is MCLK input

## functional description

### serial audio port

The serial audio port consists of a shift clock (SCLK pin), a left/right frame synchronization clock (LRCLK pin), and a data input (SDIN pin). The serial audio port supports standard serial PCM formats ( $F_s = 32\text{-kHz}$ ,  $44.1\text{-kHz}$ ,  $48\text{-kHz}$ ,  $88.2\text{-kHz}$ ,  $96\text{-kHz}$  stereo). See the *serial interface formats* section for more information.

### system clocks—master mode and slave mode

The TAS5001 allows multiple system clocking schemes. Master mode indicates that the TAS5001 provides system clocks to other parts of the system ( $M\_S=1$ ). Audio system clocks of frequency  $256 F_s$  MCLK\_OUT,  $64 F_s$  SCLK, and  $F_s$  LRCLK are output from this device when it is configured in master mode. Slave mode indicates that a system master other than the TAS5001 provides system clocks (LRCLK, SCLK, and MCLK\_IN) to the TAS5001 ( $M\_S = 0$ ). The TAS5001 operates with LRCLK and SCLK synchronized to MCLK. TAS5001 does not require any specific phase relationship between LRCLK and MCLK, but there must be synchronization. In the slave mode MCLK\_OUT is driven low. Table 1 shows all the possible master and slave modes.

### oscillator/sampling frequency

The sampling frequency is determined by the crystal (master mode) or master clock in (slave mode) which should be either  $8.192\text{ MHz}$  ( $F_s = 32\text{ kHz}$ ),  $11.2896\text{ MHz}$  ( $F_s = 44.1\text{ kHz}$ ), or  $12.288\text{ MHz}$  ( $F_s = 48\text{ kHz}$ ). Twice the normal sampling frequency can be selected by using the DBSPD pin which allows usage of  $F_s = 88.2\text{ kHz}$  or  $F_s = 96\text{ kHz}$ . In the double-speed slave mode ( $DBSPD = 1$ ,  $M\_S = 0$ ), the external clock input is either  $22.5796\text{ MHz}$  ( $F_s = 88.2\text{ kHz}$ ) or  $24.576\text{ MHz}$  ( $F_s = 96\text{ kHz}$ ). Note that  $32\text{-kHz}$  sampling is supported in the normal speed modes. Table 1 explains the proper clock selection.

**Table 1. Oscillator, External Clock, and PLL Functions**

DESCRIPTION	M_S	DBSPD	XTL_IN (MHz) <sup>†</sup>	MCLK_IN (MHz) <sup>‡</sup>	SCLK (MHz) <sup>¶</sup>	LRCLK (kHz) <sup>¶</sup>	MCLK_OUT (MHz) <sup>#</sup>
Master, normal speed	1	0	8.192	—	2.048	32	8.192
Master, normal speed	1	0	11.2896	—	2.8224	44.1	11.2896
Master, normal speed	1	0	12.288	—	3.072	48	12.288
Master, double speed	1	1	—	22.5792 <sup>§</sup>	5.6448	88.2	22.5792
Master, double speed	1	1	—	24.576 <sup>§</sup>	6.144	96	24.576
Slave, normal speed	0	0	—	8.192 <sup>§</sup>	2.048	32	Digital GND
Slave, normal speed	0	0	—	11.2896 <sup>§</sup>	2.8224	44.1	Digital GND
Slave, normal speed	0	0	—	12.288 <sup>§</sup>	3.072	48	Digital GND
Slave, double speed	0	1	—	22.5792 <sup>§</sup>	5.6448	88.2	Digital GND
Slave, double speed	0	1	—	24.576 <sup>§</sup>	6.144	96	Digital GND

<sup>†</sup> Either a crystal oscillator or an external clock of the specified frequency can be connected to XTL\_IN.

<sup>‡</sup> MCLK\_IN tied low when input to XTL\_IN is provided; XTL\_IN tied low when MCLK\_IN is provided.

<sup>§</sup> External MCLK connected to MCLK\_IN input

<sup>¶</sup> SCLK and LRCLK are outputs when  $M\_S=1$ , inputs when  $M\_S=0$ .

<sup>#</sup> MCLK\_OUT is driven low when  $M\_S=0$ .

### phase-locked loop (PLL)/clock generation

A low-jitter PLL is incorporated for internal use. Connections for the PLL external loop filter are provided as PLL\_FLT\_RET and PLL\_FLT\_OUT. If the PLL loses lock, the PWM output status pins (VALID\_L and VALID\_R) go low. Note that VALID\_L and VALID\_R can go low for other conditions as well. See the *error status reporting* section for more information.

## functional description (continued)

### digital interpolation filter

The 24-bit high-performance linear phase FIR interpolation filter up-samples the input digital data at a rate of four times (double speed mode = 88.2 kHz or 96 kHz), or eight times (normal mode = 32 kHz, 44.1 kHz, or 48 kHz) the incoming sample rate. This filter provides very low pass-band ripple and optimized time domain transient response for accurate music reproduction.

### digital PWM modulator

The interpolation filter output is sent to the modulator. This modulator consists of a high performance fourth order digital noise shaper and a PCM-to-PWM converter. Following the noise shaper, the PCM signal is fed into a very low distortion PCM-to-PWM conversion block, buffered, and output from the chip. The modulation scheme is based on a 2-state control of the H-bridge output.

### control, status, and operational modes

The TAS5001 control section consists of several control-input pins. Three serial mode pins (MOD0, MOD1, and MOD2) are provided to select various serial data formats. During normal operating conditions if any of the MOD0, MOD1, or MOD2 pins changes state, a reset sequence is initiated. Also provided are separate power-down (PDN), reset (RESET), and mute (MUTE) pins.

### power up

At power up the VALID\_L and VALID\_R pins are asserted low and the PWM outputs go to the hard mute state in which the P outputs are held low and the M outputs are held high. Following initialization, the TAS5001 comes up in the operational state (differential PWM audio). There are two cases of power-up timing. The first case is shown in Figure 1 with RESET preceding PDN. The second case is shown in Figure 2 with PDN preceding RESET.

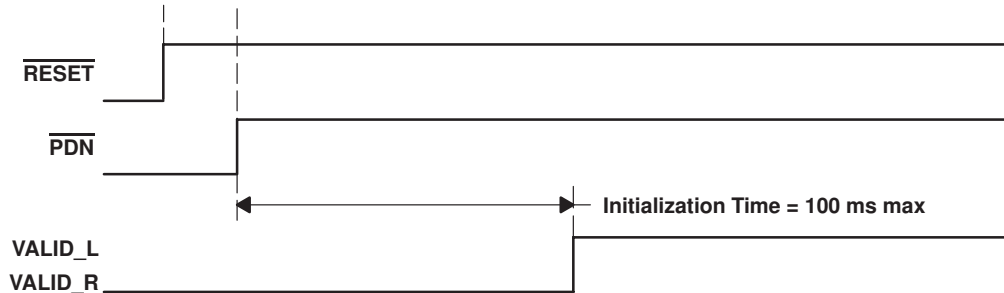

Figure 1. Power-Up Timing (RESET Preceding PDN)

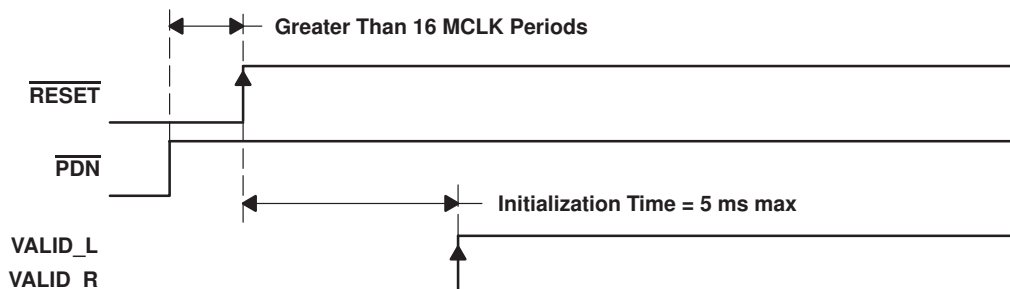

Figure 2. Power-Up Timing (PDN Preceding RESET)

## functional description (continued)

### reset

The reset signal for the TAS5001 must be applied whenever toggling the  $\overline{M\_S}$ , DBSPD signal. This reset is asynchronous. See Figure 3 for reset timing. To initiate the reset sequence the  $\overline{RESET}$  pin is asserted low. As long as the pin is held low the chip is in the reset state. During this reset time the PWM outputs are hard-muted (P-outputs held low and M-outputs held high) and the PWM outputs valid pins ( $\overline{VALID\_L}$ ,  $\overline{VALID\_R}$ ) are held low. Assuming  $\overline{PDN}$  is high, the rising edge of the reset pulse begins chip initialization. After the initialization time, the TAS5001 begins normal operation.

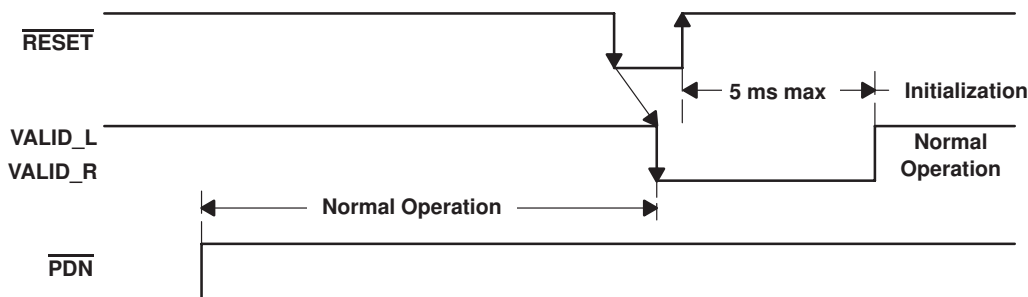

Figure 3. Reset Timing

### power down

When  $\overline{PDN}$  is low (see Figure 4), both the PLL and the oscillator are shut down. Note that power down is an asynchronous operation. To place the device in total power-down mode, both  $\overline{RESET}$  and  $\overline{PDN}$  must be held low. As long as these pins are held low, the chip is in the power-down state and the PWM outputs are hard muted with the P outputs held low and the M outputs held high. To place the device back into normal mode, see the *power up* section.

**NOTE:** In order for the dynamic logic to be properly powered down, the clocks should not be stopped before the  $\overline{PDN}$  pin goes low. Otherwise, the device may drain additional supply current.

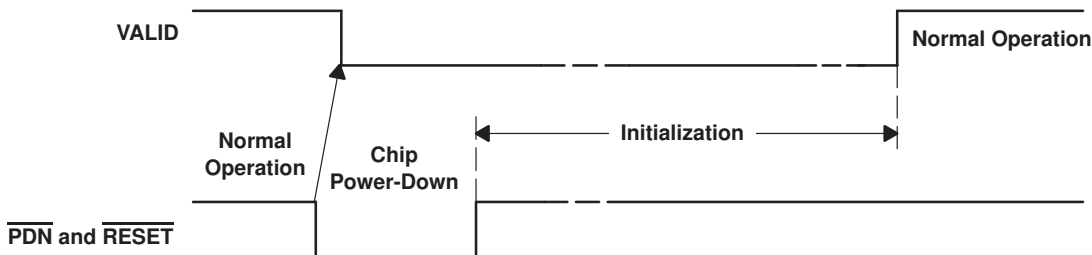

Figure 4. Power-Down Timing

### mute

The TAS5001 provides a mute function that is used when the  $\overline{MUTE}$  pin is asserted low. See Table 2 for mute description. This mute is a quiet mute; that is, the mute is accomplished by outputting a zero value waveform in which both sides of the differential PWM outputs have a 50% duty cycle (see Figure 5 for mute timing).

Table 2. Mute Description

$\overline{MUTE}$	PWM_P	PWM_M	DESCRIPTION
0	50% duty cycle	50% duty cycle	Mute
1	DATA	$\overline{DATA}$	Normal operation

functional description (continued)

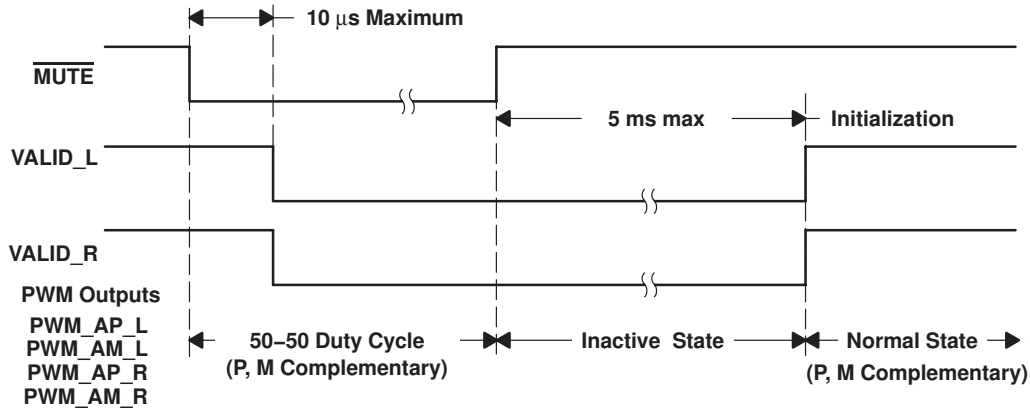

Figure 5. Mute Timing

double speed

Double-speed mode is used to support sampling rates of 88.2 kHz and 96 kHz. In order to put the TAS5001 in double-speed mode with the device in normal operating conditions, the RESET pin must be held low while switching the DBSPD pin high. After the RESET pin is brought high again, a reset sequence takes place. If the change is at power up, a power-up sequence is originated.

de-emphasis filter

For audio sources that have been preemphasized, a precision 50-μs/15-μs de-emphasis filter is provided to support the sampling rates of 44.1 kHz and 48 kHz. Pins DEM\_SEL and DEM\_EN select the de-emphasis functions. See Figure 6 for a graph showing the de-emphasis filtering characteristics. See Table 3 for de-emphasis selection.

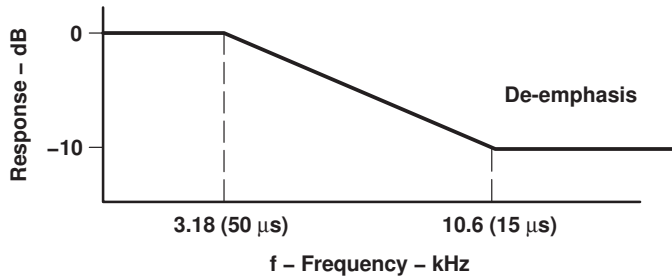

Figure 6. De-Emphasis Filter Characteristics



**functional description (continued)****de-emphasis selection**

De-emphasis selection is accomplished by using the DEM\_SEL and DEM\_EN pins. See Table 3 for de-emphasis selection description.

**Table 3. De-Emphasis Selection**

DEM_SEL	DEM_EN	DESCRIPTION
0	0	De-emphasis disabled
0	1	De-emphasis enabled for Fs = 44.1 kHz
1	1	De-emphasis enabled for Fs = 48 kHz
1	0	Forbidden mode. Do not use.

**error status reporting (VALID\_L and VALID\_R)**

The following is a list of the error conditions that will cause the VALID\_L and VALID\_R pins to be asserted low:

- No clocks
- Clock phase errors

When either of the above conditions is met, the VALID\_L and VALID\_R goes low and the PWM outputs go to the hard mute state. If the error condition is removed, the TAS5001 is reinitialized and the VALID\_L and VALID\_R pins are asserted high.

**serial interface formats**

The TAS5001 is compatible with eight different serial interfaces. Available interface options are IIS, right justified, left justified, and DSP frame. Table 4 indicates how these options are selected using the MOD0, MOD1, and MOD2 pins.

**Table 4. Hardware Selection of Serial Audio Modes**

MODE	MOD2 PIN	MOD1 PIN	MOD0 PIN	SERIAL INTERFACE SDIN
0	0	0	0	16 bit, MSB first; right justified
1	0	0	1	20 bit, MSB first; right justified
2	0	1	0	24 bit, MSB first; right justified
3	0	1	1	16 bit IIS
4	1	0	0	20 bit IIS
5	1	0	1	24 bit IIS
6	1	1	0	16 bit MSB first, left justified
7	1	1	1	16 bit DSP frame

The following figures illustrate the relationship between the SCLK, LRCLK and the serial data I/O for the different interface protocols. Note that there are always 64 SCLKs per LRCLK. The nondata bits are padded with binary 0s.

functional description (continued)

MSB first, right-justified (for 16, 20, 24 bits)

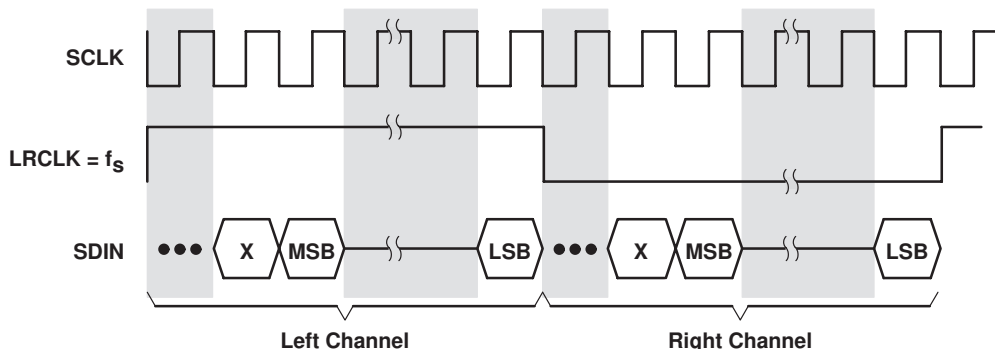

Figure 7. MSB First Right Justified

Note the following characteristics of this protocol:

- Left channel is received when LRCLK is high.
- Right channel is received when LRCLK is low.
- SDIN is sampled at the rising edge of SCLK.

IIS compatible serial format (for 16, 20, 24 bits)

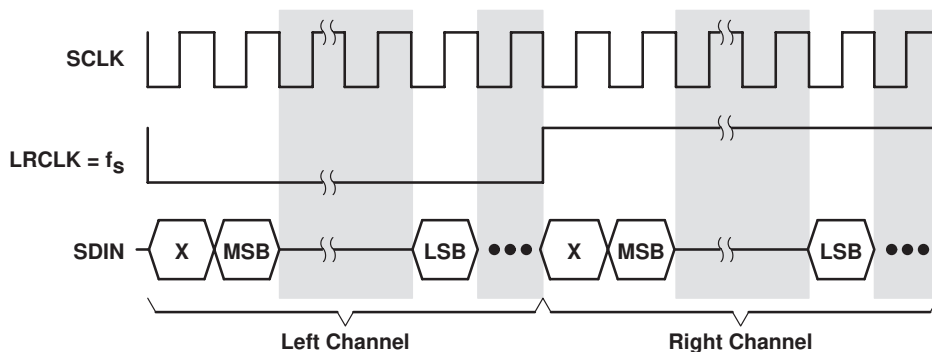
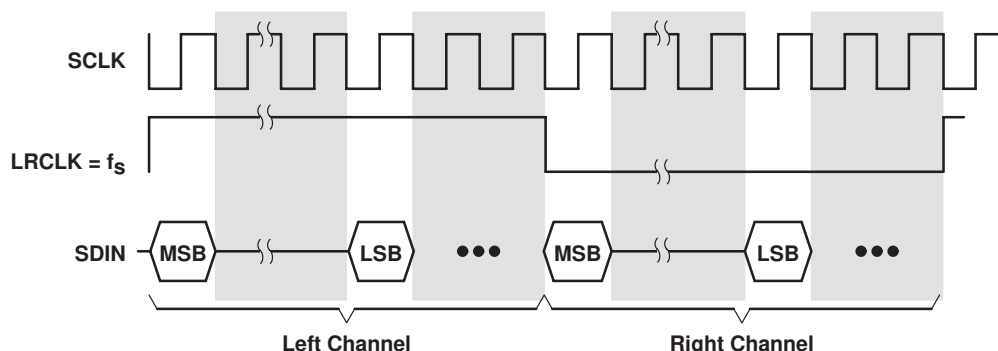

Figure 8. IIS Compatible Serial Format

Note the following characteristics of this protocol:

- Left channel is received when LRCLK is low.
- Right channel is received when LRCLK is high.
- SDIN is sampled with the rising edge of the SCLK.

**functional description (continued)****MSB left-justified serial interface format (for 16 bits)****Figure 9. MSB Left-Justified Serial Interface Format**

Note the following characteristics of this protocol:

- Left channel is received when LRCLK is high.
- Right channel is received when LRCLK is low.
- SDIN is sampled at the rising edge of SCLK.

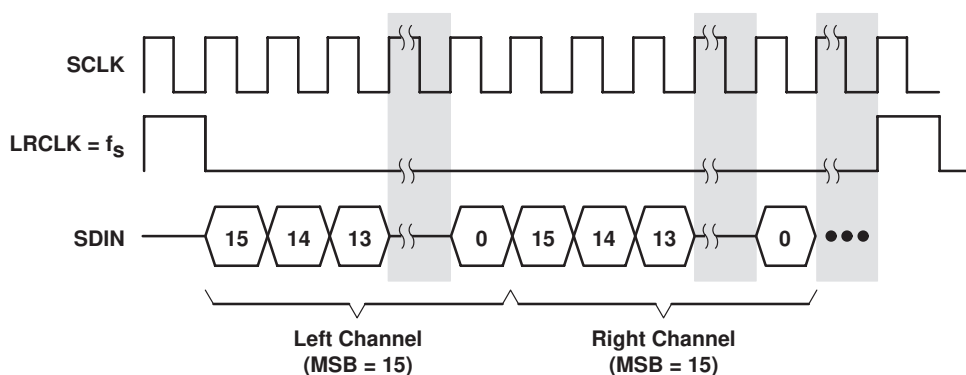
**DSP compatible serial interface format (for 16 bits)****Figure 10. DSP Compatible Serial Interface Format**

Note the following characteristics of this protocol:

- Serial data is sampled with the falling edge of SCLK.

**PWM outputs**

Designed to be used with the TAS5100 family of H-Bridges, the PWM outputs provide differential 3.3-V square-wave signals. During normal operation these outputs represent the input PCM audio in the pulse-width modulation scheme. In the hard-mute state the P outputs (PWM\_AP\_L and PWM\_AP\_R) are held low and the M outputs (PWM\_AM\_L and PWM\_AM\_R) are held high. In the quiet-mute state the differential PWM outputs have a 50% duty cycle.

**absolute maximum ratings over operating free-air temperature (unless otherwise noted)†**

Analog supply voltage range, AVDD1, AVDD2 .....	-0.3 V to 4.2 V
Digital power supply voltage, DVDD1, DVDD2, DVDD3_L, DVDD3_R .....	-0.3 V to 4.2 V
Digital input voltage, V <sub>I</sub> (see Note 1) .....	-0.3 V to DV <sub>DDX</sub> + 0.3 V
Operating free-air temperature, T <sub>A</sub> .....	0°C to 70°C
Storage temperature, T <sub>stg</sub> .....	-65°C to 150°C
ESD .....	2000 V

† Stresses beyond those listed under “absolute maximum ratings” may cause permanent damage to the device. These are stress ratings only, and functional operation of the device at these or any other conditions beyond those indicated under “recommended operating conditions” is not implied. Exposure to absolute-maximum-rated conditions for extended periods may affect device reliability.

NOTE 1: DVDD1, DVDD2, DVDD3\_L, DVDD3\_R

**recommended operating conditions, T<sub>A</sub> = 25°C, DVDD1 = DVDD2 = DVDD3\_L = DVDD3\_R = 3.3 V ±10%, AVDD1 = AVDD2 = 3.3 V ±10%, F<sub>s</sub> = 44.1 kHz**

			MIN	TYP	MAX	UNIT
Supply voltage	Digital	DVDDx‡	3	3.3	3.6	V
Supply current	Digital	Operating		22		mA
		Power down§		10	20	µA
Power dissipation	Digital	Operating		59.4		mW
		Power down§		6.6	72	µW
Supply voltage	Analog	AVDDx¶	3	3.3	3.6	V
Supply current	Analog	Operating		8		mA
		Power down§		10	100	µA
Power dissipation	Analog	Operating		26.4		mW
		Power down§		33	360	µW

‡ DVDD1, DVDD2, DVDD3\_L, DVDD3\_R

§ If the clocks are turned off

¶ AVDD1, AVDD2

**electrical characteristics, T<sub>A</sub> = 25°C; DVDD1 = DVDD2 = DVDD3\_L = DVDD3\_R = 3.3 V ±10%, AVDD1 = AVDD2 = 3.3 V ±10%**

**static digital specifications**

PARAMETER		TEST CONDITIONS	MIN	TYP	MAX	UNIT
V <sub>IH</sub>	High-level input voltage		2		DVDD	V
V <sub>IL</sub>	Low-level input voltage		0		0.8	V
V <sub>OH</sub>	High-level output voltage	I <sub>O</sub> = -1 mA	2.4			V
V <sub>OL</sub>	Low-level output voltage	I <sub>O</sub> = 4 mA			0.4	V
I <sub>Ikg</sub>	Input leakage current		-10		10	µA

**digital interpolation filter and PWM modulator, F<sub>s</sub> = 44.1 kHz**

PARAMETER	TEST CONDITIONS	MIN	TYP	MAX	UNIT
Pass band		0		20	kHz
Pass-band ripple			±0.012		dB
Stop band			24.1		kHz
Stop-band attenuation	24.1 kHz to 152.3 kHz	50			dB
Group delay			700		µS
PWM modulation index (gain)			0.93		dB

**TAS5001/TAS5100 system performance measured at the speaker terminals**

See application note, literature number SLAA117.

**switching characteristics,  $T_A = 25^\circ\text{C}$ ,  
 $DVDD1 = DVDD2 = DVDD3\_L = DVDD3\_R = AVDD1 = AVDD2 = 3.3\text{ V} \pm 10\%$**

**serial audio ports slave mode**

PARAMETER		MIN	TYP	MAX	UNIT
$f(\text{SCLK})$	SCLK frequency			6.144	MHz
$t_{\text{su}}(\text{SDIN})$	SDIN setup time before SCLK rising edge	20			ns
$t_{\text{h}}(\text{SDIN})$	SDIN hold time from SCLK rising edge	10			ns
$f(\text{LRCLK})$	LRCLK frequency	32	48	96	kHz
	MCLK duty cycle		50%		
	SCLK duty cycle		50%		
	LRCLK duty cycle		50%		
$t_{\text{su}}(\text{LRCLK})$	LRCLK edge setup before SCLK rising edge	20			ns

**serial audio ports master mode, load conditions = 50 pF**

PARAMETER		MIN	TYP	MAX	UNIT
$t(\text{MSD})$	MCLK to SCLK	0		5	ns
$t(\text{MLRD})$	MLCK to LRCLK	0		5	ns

**DSP serial interface mode**

PARAMETER		MIN	TYP	MAX	UNIT
$f(\text{SCLK})$	SCLK frequency			6.144	MHz
$t_{\text{W}}(\text{FSHIGH})$	Pulse duration, sync		$1/(64 \times F_s)$		ns
$t_{\text{su}}(\text{SDIN}),$ $t_{\text{su}}(\text{LRCLK})$	SDIN and LRCLK setup time before SCLK falling edge	20			ns
$t_{\text{h}}(\text{SDIN}),$ $t_{\text{h}}(\text{LRCLK})$	SDIN and LRCLK hold time from SCLK falling edge	10			ns
	SCLK duty cycle		50%		

PARAMETER MEASUREMENT INFORMATION

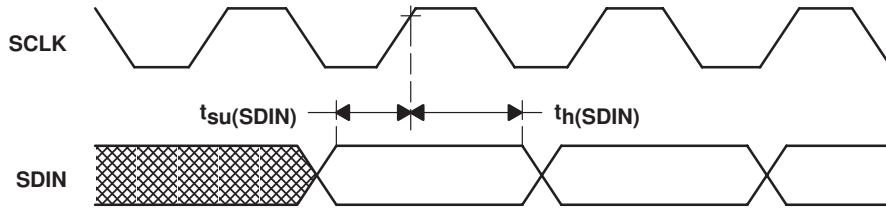
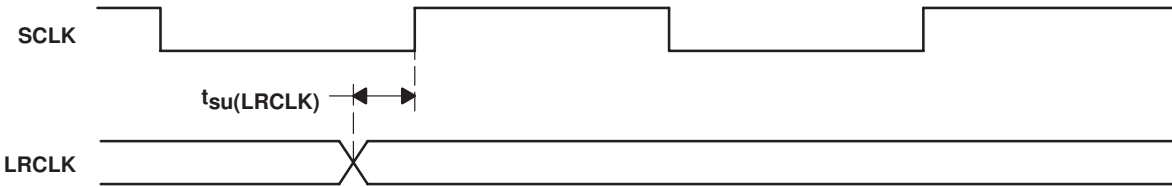

Figure 11. Right-Justified, IIS, Left-Justified Serial Protocol Timing



NOTE: Serial data is sampled with the rising edge of SCLK (setup time = 20 ns and hold time = 10 ns)

Figure 12. Right, Left, and IIS Serial Mode Timing Requirement

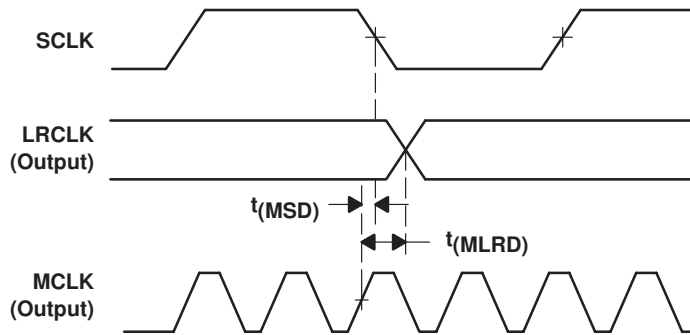

Figure 13. Serial Audio Ports Master Mode Timing

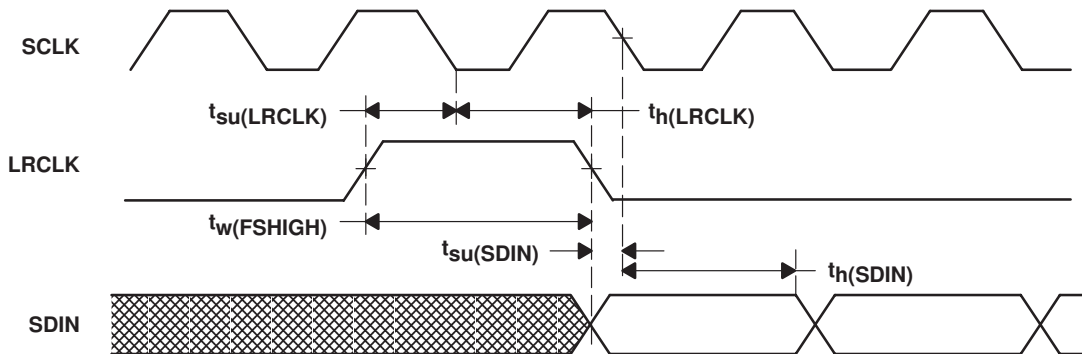

Figure 14. DSP Serial Port Timing

PARAMETER MEASUREMENT INFORMATION

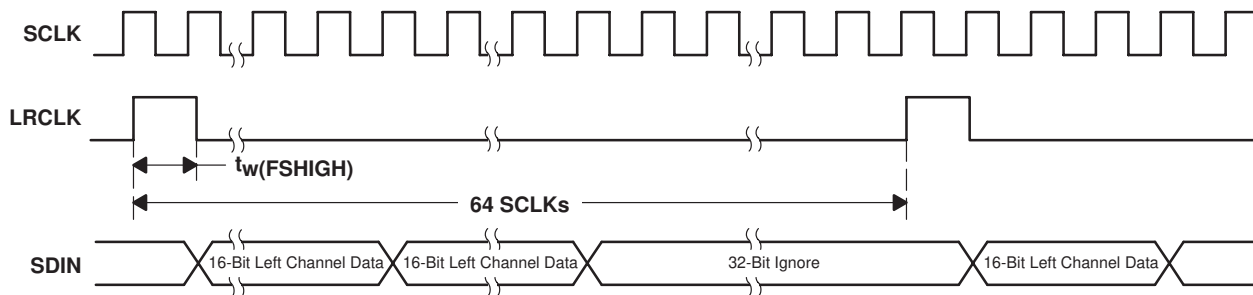
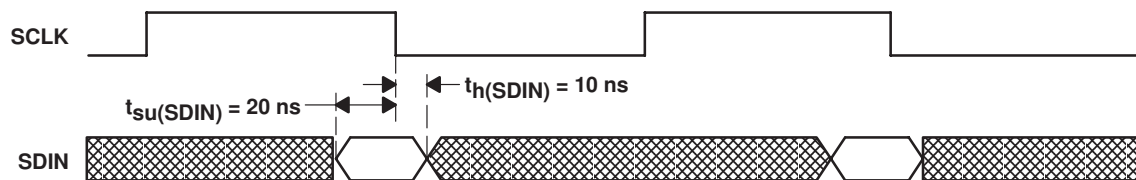

Figure 15. DSP Serial Port Expanded Timing



NOTE: Serial data is sampled with the falling edge of SCLK (setup time = 20 ns and hold time = 10 ns)

Figure 16. DSP Absolute Timing Requirement

APPLICATION INFORMATION

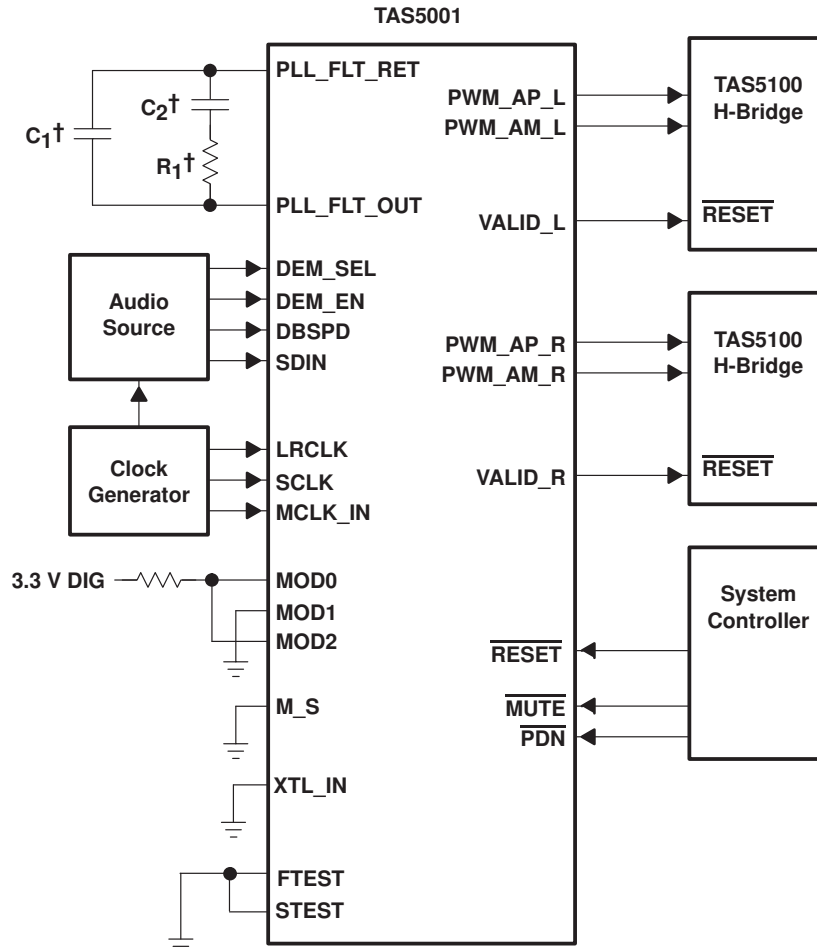

† See application note, literature number SLAA117 for values



MECHANICAL DATA

PFB (S-PQFP-G48)

PLASTIC QUAD FLATPACK

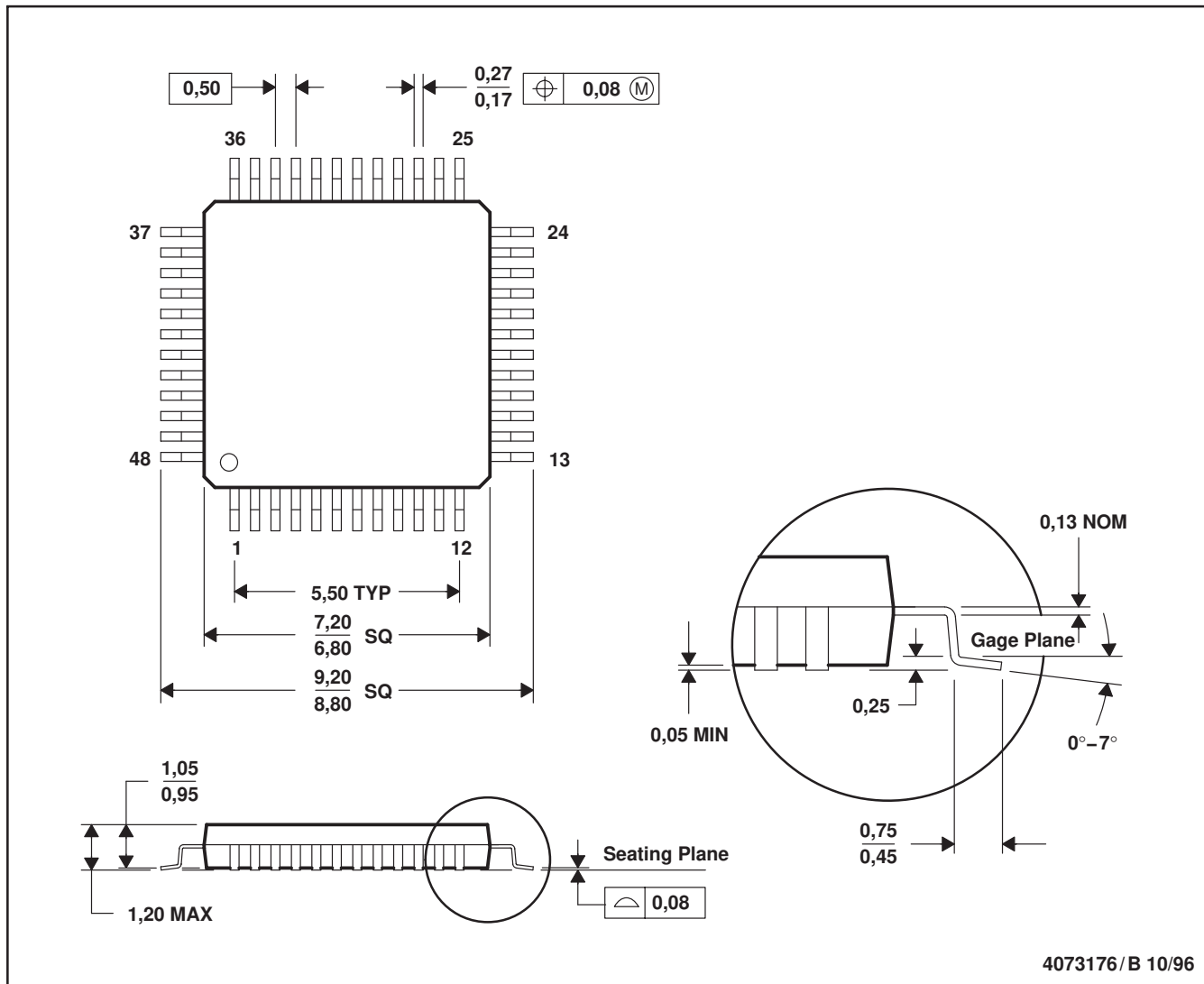

- NOTES: A. All linear dimensions are in millimeters.  
 B. This drawing is subject to change without notice.  
 C. Falls within JEDEC MS-026

**PACKAGING INFORMATION**

Orderable Device	Status <sup>(1)</sup>	Package Type	Package Drawing	Pins	Package Qty	Eco Plan <sup>(2)</sup>	Lead/Ball Finish	MSL Peak Temp <sup>(3)</sup>
TAS5001IPFB	ACTIVE	TQFP	PFB	48	250	Green (RoHS & no Sb/Br)	CU NIPDAU	Level-2-260C-1 YEAR
TAS5001IPFBG4	ACTIVE	TQFP	PFB	48	250	Green (RoHS & no Sb/Br)	CU NIPDAU	Level-2-260C-1 YEAR
TAS5001PFB	ACTIVE	TQFP	PFB	48	250	Green (RoHS & no Sb/Br)	CU NIPDAU	Level-2-260C-1 YEAR
TAS5001PFBG4	ACTIVE	TQFP	PFB	48	250	Green (RoHS & no Sb/Br)	CU NIPDAU	Level-2-260C-1 YEAR
TAS5001PFBR	ACTIVE	TQFP	PFB	48	1000	Green (RoHS & no Sb/Br)	CU NIPDAU	Level-2-260C-1 YEAR
TAS5001PFBRG4	ACTIVE	TQFP	PFB	48	1000	Green (RoHS & no Sb/Br)	CU NIPDAU	Level-2-260C-1 YEAR

<sup>(1)</sup> The marketing status values are defined as follows:

**ACTIVE:** Product device recommended for new designs.

**LIFEBUY:** TI has announced that the device will be discontinued, and a lifetime-buy period is in effect.

**NRND:** Not recommended for new designs. Device is in production to support existing customers, but TI does not recommend using this part in a new design.

**PREVIEW:** Device has been announced but is not in production. Samples may or may not be available.

**OBSOLETE:** TI has discontinued the production of the device.

<sup>(2)</sup> Eco Plan - The planned eco-friendly classification: Pb-Free (RoHS), Pb-Free (RoHS Exempt), or Green (RoHS & no Sb/Br) - please check <http://www.ti.com/productcontent> for the latest availability information and additional product content details.

**TBD:** The Pb-Free/Green conversion plan has not been defined.

**Pb-Free (RoHS):** TI's terms "Lead-Free" or "Pb-Free" mean semiconductor products that are compatible with the current RoHS requirements for all 6 substances, including the requirement that lead not exceed 0.1% by weight in homogeneous materials. Where designed to be soldered at high temperatures, TI Pb-Free products are suitable for use in specified lead-free processes.

**Pb-Free (RoHS Exempt):** This component has a RoHS exemption for either 1) lead-based flip-chip solder bumps used between the die and package, or 2) lead-based die adhesive used between the die and leadframe. The component is otherwise considered Pb-Free (RoHS compatible) as defined above.

**Green (RoHS & no Sb/Br):** TI defines "Green" to mean Pb-Free (RoHS compatible), and free of Bromine (Br) and Antimony (Sb) based flame retardants (Br or Sb do not exceed 0.1% by weight in homogeneous material)

<sup>(3)</sup> MSL, Peak Temp. -- The Moisture Sensitivity Level rating according to the JEDEC industry standard classifications, and peak solder temperature.

**Important Information and Disclaimer:**The information provided on this page represents TI's knowledge and belief as of the date that it is provided. TI bases its knowledge and belief on information provided by third parties, and makes no representation or warranty as to the accuracy of such information. Efforts are underway to better integrate information from third parties. TI has taken and continues to take reasonable steps to provide representative and accurate information but may not have conducted destructive testing or chemical analysis on incoming materials and chemicals. TI and TI suppliers consider certain information to be proprietary, and thus CAS numbers and other limited information may not be available for release.

In no event shall TI's liability arising out of such information exceed the total purchase price of the TI part(s) at issue in this document sold by TI to Customer on an annual basis.

**TAPE AND REEL INFORMATION**

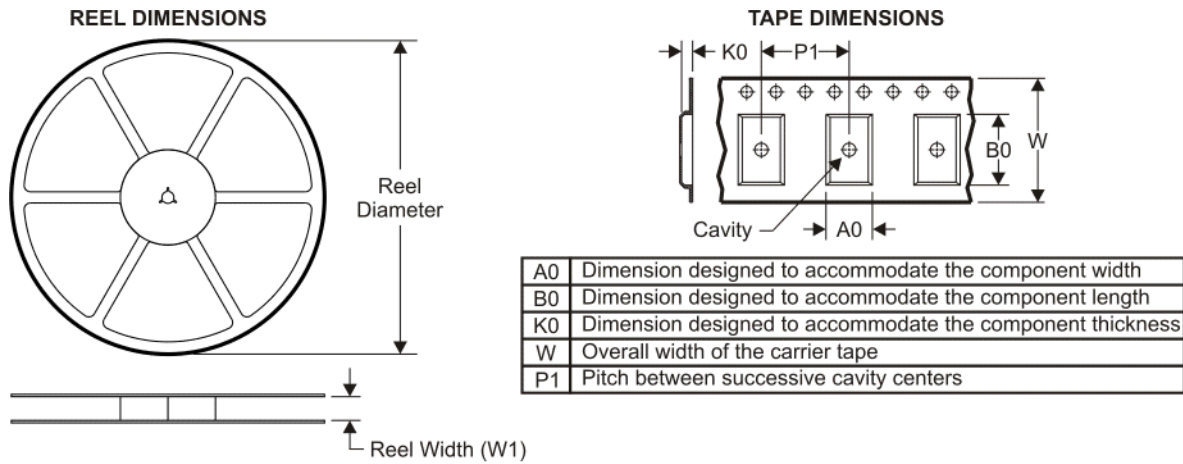

**QUADRANT ASSIGNMENTS FOR PIN 1 ORIENTATION IN TAPE**

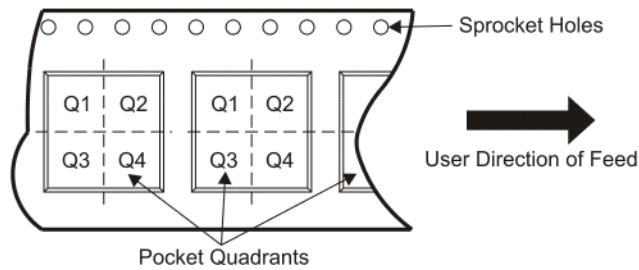

\*All dimensions are nominal

Device	Package Type	Package Drawing	Pins	SPQ	Reel Diameter (mm)	Reel Width W1 (mm)	A0 (mm)	B0 (mm)	K0 (mm)	P1 (mm)	W (mm)	Pin1 Quadrant
TAS5001PFBR	TQFP	PFB	48	1000	330.0	16.4	9.6	9.6	1.5	12.0	16.0	Q2

**TAPE AND REEL BOX DIMENSIONS**



\*All dimensions are nominal

Device	Package Type	Package Drawing	Pins	SPQ	Length (mm)	Width (mm)	Height (mm)
TAS5001PFBR	TQFP	PFB	48	1000	346.0	346.0	33.0

## IMPORTANT NOTICE

Texas Instruments Incorporated and its subsidiaries (TI) reserve the right to make corrections, modifications, enhancements, improvements, and other changes to its products and services at any time and to discontinue any product or service without notice. Customers should obtain the latest relevant information before placing orders and should verify that such information is current and complete. All products are sold subject to TI's terms and conditions of sale supplied at the time of order acknowledgment.

TI warrants performance of its hardware products to the specifications applicable at the time of sale in accordance with TI's standard warranty. Testing and other quality control techniques are used to the extent TI deems necessary to support this warranty. Except where mandated by government requirements, testing of all parameters of each product is not necessarily performed.

TI assumes no liability for applications assistance or customer product design. Customers are responsible for their products and applications using TI components. To minimize the risks associated with customer products and applications, customers should provide adequate design and operating safeguards.

TI does not warrant or represent that any license, either express or implied, is granted under any TI patent right, copyright, mask work right, or other TI intellectual property right relating to any combination, machine, or process in which TI products or services are used. Information published by TI regarding third-party products or services does not constitute a license from TI to use such products or services or a warranty or endorsement thereof. Use of such information may require a license from a third party under the patents or other intellectual property of the third party, or a license from TI under the patents or other intellectual property of TI.

Reproduction of TI information in TI data books or data sheets is permissible only if reproduction is without alteration and is accompanied by all associated warranties, conditions, limitations, and notices. Reproduction of this information with alteration is an unfair and deceptive business practice. TI is not responsible or liable for such altered documentation. Information of third parties may be subject to additional restrictions.

Resale of TI products or services with statements different from or beyond the parameters stated by TI for that product or service voids all express and any implied warranties for the associated TI product or service and is an unfair and deceptive business practice. TI is not responsible or liable for any such statements.

TI products are not authorized for use in safety-critical applications (such as life support) where a failure of the TI product would reasonably be expected to cause severe personal injury or death, unless officers of the parties have executed an agreement specifically governing such use. Buyers represent that they have all necessary expertise in the safety and regulatory ramifications of their applications, and acknowledge and agree that they are solely responsible for all legal, regulatory and safety-related requirements concerning their products and any use of TI products in such safety-critical applications, notwithstanding any applications-related information or support that may be provided by TI. Further, Buyers must fully indemnify TI and its representatives against any damages arising out of the use of TI products in such safety-critical applications.

TI products are neither designed nor intended for use in military/aerospace applications or environments unless the TI products are specifically designated by TI as military-grade or "enhanced plastic." Only products designated by TI as military-grade meet military specifications. Buyers acknowledge and agree that any such use of TI products which TI has not designated as military-grade is solely at the Buyer's risk, and that they are solely responsible for compliance with all legal and regulatory requirements in connection with such use.

TI products are neither designed nor intended for use in automotive applications or environments unless the specific TI products are designated by TI as compliant with ISO/TS 16949 requirements. Buyers acknowledge and agree that, if they use any non-designated products in automotive applications, TI will not be responsible for any failure to meet such requirements.

Following are URLs where you can obtain information on other Texas Instruments products and application solutions:

### Products

Amplifiers	<a href="http://amplifier.ti.com">amplifier.ti.com</a>
Data Converters	<a href="http://dataconverter.ti.com">dataconverter.ti.com</a>
DSP	<a href="http://dsp.ti.com">dsp.ti.com</a>
Clocks and Timers	<a href="http://www.ti.com/clocks">www.ti.com/clocks</a>
Interface	<a href="http://interface.ti.com">interface.ti.com</a>
Logic	<a href="http://logic.ti.com">logic.ti.com</a>
Power Mgmt	<a href="http://power.ti.com">power.ti.com</a>
Microcontrollers	<a href="http://microcontroller.ti.com">microcontroller.ti.com</a>
RFID	<a href="http://www.ti-rfid.com">www.ti-rfid.com</a>
RF/IF and ZigBee® Solutions	<a href="http://www.ti.com/lprf">www.ti.com/lprf</a>

### Applications

Audio	<a href="http://www.ti.com/audio">www.ti.com/audio</a>
Automotive	<a href="http://www.ti.com/automotive">www.ti.com/automotive</a>
Broadband	<a href="http://www.ti.com/broadband">www.ti.com/broadband</a>
Digital Control	<a href="http://www.ti.com/digitalcontrol">www.ti.com/digitalcontrol</a>
Medical	<a href="http://www.ti.com/medical">www.ti.com/medical</a>
Military	<a href="http://www.ti.com/military">www.ti.com/military</a>
Optical Networking	<a href="http://www.ti.com/opticalnetwork">www.ti.com/opticalnetwork</a>
Security	<a href="http://www.ti.com/security">www.ti.com/security</a>
Telephony	<a href="http://www.ti.com/telephony">www.ti.com/telephony</a>
Video & Imaging	<a href="http://www.ti.com/video">www.ti.com/video</a>
Wireless	<a href="http://www.ti.com/wireless">www.ti.com/wireless</a>

Mailing Address: Texas Instruments, Post Office Box 655303, Dallas, Texas 75265  
Copyright © 2008, Texas Instruments Incorporated