

TUSB320 USB Type-C™ Configuration Channel Logic and Port Control

1 Features

- USB Type-C™ Specification 1.1
- Backward Compatible with USB Type-C Specification 1.0
- Supports Up to 3 A of Current Advertisement and Detection
- Mode Configuration
 - Host Only – DFP (Source)
 - Device Only – UFP (Sink)
 - Dual Role Port – DRP
- Channel Configuration (CC)
 - Attach of USB Port Detection
 - Cable Orientation Detection
 - Role Detection
 - Type-C Current Mode (Default, Medium, High)
- V_{BUS} Detection
- I²C or GPIO Control
- Role Configuration Control through I²C
- Supply Voltage: 2.7 V to 5 V
- Low Current Consumption
- Industrial Temperature Range of –40 to 85°C

2 Applications

- Host, Device, Dual Role Port Applications
- Mobile Phones
- Tablets and Notebooks
- USB Peripherals

4 Simplified Schematic

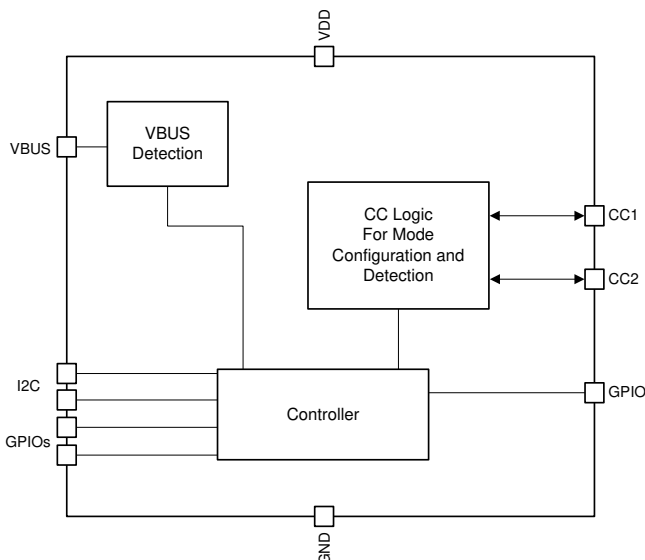

3 Description

The TUSB320 device enables USB Type-C ports with the configuration channel (CC) logic needed for Type-C ecosystems. The TUSB320 device uses the CC pins to determine port attach and detach, cable orientation, role detection, and port control for Type-C current mode. The TUSB320 device can be configured as a downstream facing port (DFP), upstream facing port (UFP) or a dual role port (DRP) making it ideal for any application.

The TUSB320 device alternates configuration as a DFP or UFP according to the Type-C Specifications. The CC logic block monitors the CC1 and CC2 pins for pullup or pulldown resistances to determine when a USB port has been attached, the orientation of the cable, and the role detected. The CC logic detects the Type-C current mode as default, medium, or high depending on the role detected. V_{BUS} detection is implemented to determine a successful attach in UFP and DRP modes.

The device operates over a wide supply range and has low-power consumption. The TUSB320 device is available in industrial and commercial temperature ranges.

Device Information⁽¹⁾

PART NUMBER	PACKAGE	BODY SIZE (NOM)
TUSB320	X2QFN (12)	1.60 mm × 1.60 mm
TUSB320I	X2QFN (12)	1.60 mm × 1.60 mm

(1) For all available packages, see the orderable addendum at the end of the data sheet.



Sample Applications



Table of Contents

1 Features	1	8.4 Programming.....	13
2 Applications	1	8.5 Register Maps	14
3 Description	1	9 Application and Implementation	17
4 Simplified Schematic	1	9.1 Application Information.....	17
5 Revision History	2	9.2 Typical Application	18
6 Pin Configuration and Functions	3	9.3 Initialization Set Up	24
7 Specifications	4	10 Power Supply Recommendations	24
7.1 Absolute Maximum Ratings	4	11 Layout	24
7.2 ESD Ratings.....	4	11.1 Layout Guidelines	24
7.3 Recommended Operating Conditions	4	11.2 Layout Example	24
7.4 Thermal Information	4	12 Device and Documentation Support	25
7.5 Electrical Characteristics.....	5	12.1 Related Links	25
7.6 Timing Requirements	6	12.2 Community Resources.....	25
7.7 Switching Characteristics	6	12.3 Trademarks	25
8 Detailed Description	7	12.4 Electrostatic Discharge Caution.....	25
8.1 Overview	7	12.5 Glossary	25
8.2 Feature Description.....	8	13 Mechanical, Packaging, and Orderable Information	25
8.3 Device Functional Modes.....	11		

5 Revision History

Changes from Original (May 2015) to Revision A	Page
• Changed device status of TUSB320 from <i>Product Preview</i> to <i>Production Data</i>	1

6 Pin Configuration and Functions

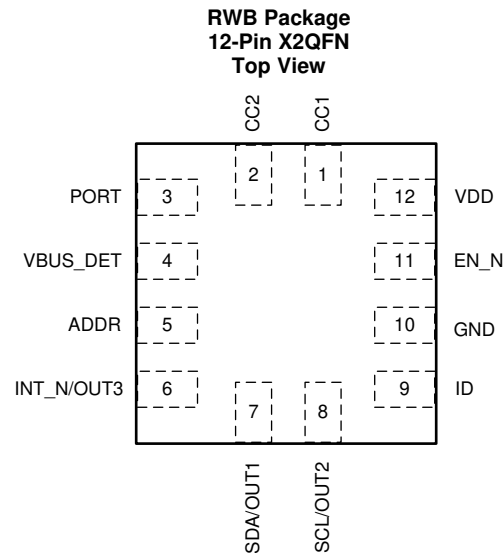

Pin Functions

PIN		I/O	DESCRIPTION
NAME	NO.		
CC1	1	I/O	Type-C configuration channel signal 1
CC2	2	I/O	Type-C configuration channel signal 2
PORT	3	I	Tri-level input pin to indicate port mode. The state of this pin is sampled when EN_N is asserted low and VDD is active. This pin is also sampled following a I2C_SOFT_RESET. H - DFP (Pull-up to VDD if DFP mode is desired) NC - DRP (Leave unconnected if DRP mode is desired) L - UFP (Pull-down or tie to GND if UFP mode is desired)
VBUS_DET	4	I	5- to 28-V VBUS input voltage. VBUS detection determines UFP attachment. One 900-kΩ external resistor required between system VBUS and VBUS_DET pin.
ADDR	5	I	Tri-level input pin to indicate I2C address or GPIO mode: H - I2C is enabled and I2C 7-bit address is 0x61. NC - GPIO mode (I2C is disabled) L - I2C is enabled and I2C 7-bit address is 0x60. ADDR pin should be pulled up to VDD if high configuration is desired
INT_N/OUT3	6	O	The INT_N/OUT3 is a dual-function pin. When used as the INT_N, the pin is an open drain output in I2C control mode and is an active low interrupt signal for indicating changes in I2C registers. When used as OUT3, the pin is in audio accessory detect in GPIO mode: no detection (H), audio accessory connection detected (L).
SDA/OUT1	7	I/O	The SDA/OUT1 is a dual-function pin. When I2C is enabled (ADDR pin is high or low), this pin is the I2C communication data signal. When in GPIO mode (ADDR pin is NC), this pin is an open drain output for communicating Type-C current mode detect when the TUSB320 device is in UFP mode: default current mode detected (H); medium or high current mode detected (L).
SCL/OUT2	8	I/O	The SCL/OUT2 is a dual function pin. When I2C is enabled (ADDR pin is high or low), this pin is the I2C communication clock signal. When in GPIO mode (ADDR pin is NC), this pin is an open drain output for communicating Type-C current mode detect when the TUSB320 device is in UFP mode: default or medium current mode detected (H); high current mode detected (L).
ID	9	O	Open drain output; asserted low when the CC pins detect device attachment when port is a source (DFP), or dual-role (DRP) acting as source (DFP).
GND	10	G	Ground
EN_N	11	I	Enable signal; active low. Pulled up to VDD internally to disable the TUSB320 device.
VDD	12	P	Positive supply voltage

7 Specifications

7.1 Absolute Maximum Ratings

over operating free-air temperature range (unless otherwise noted)⁽¹⁾

		MIN	MAX	UNIT
Supply voltage	V _{DD}	-0.3	6.0	V
Control pins	CC1, CC2, PORT, ADDR, ID, EN_N, INT_N/OUT3	-0.3	V _{DD} + 0.3	V
	SDA/OUT1, SCL/OUT2	-0.3	V _{DD} + 0.3	
	VBUS_DET	-0.3	4	
Storage temperature, T _{stg}		-65	150	°C

(1) Stresses beyond those listed under *Absolute Maximum Ratings* may cause permanent damage to the device. These are stress ratings only, which do not imply functional operation of the device at these or any other conditions beyond those indicated under *Recommended Operating Conditions*. Exposure to absolute-maximum-rated conditions for extended periods may affect device reliability.

7.2 ESD Ratings

		VALUE	UNIT
V _(ESD) Electrostatic discharge	Human-body model (HBM), per ANSI/ESDA/JEDEC JS-001 ⁽¹⁾	±7000	V
	Charged-device model (CDM), per JEDEC specification JESD22-C101 ⁽²⁾	±1500	

(1) JEDEC document JEP155 states that 500-V HBM allows safe manufacturing with a standard ESD control process.

(2) JEDEC document JEP157 states that 250-V CDM allows safe manufacturing with a standard ESD control process.

7.3 Recommended Operating Conditions

over operating free-air temperature range (unless otherwise noted)

		MIN	NOM	MAX	UNIT
V _{DD}	Supply voltage range	2.7		5	V
V _{BUS}	System V _{BUS} voltage	4	5	28	V
VBUS_DET	VBUS_DET threshold voltage on the pin			4	V
T _A	TUSB320I Operating free air temperature range	-40	25	85	°C
	TUSB320 Operating free air temperature range	0	25	70	°C

7.4 Thermal Information

THERMAL METRIC ⁽¹⁾		X2QFN	UNIT
		TUSB320	
		12 PINS	
R _{θJA}	Junction-to-ambient thermal resistance	169.3	°C/W
R _{θJC(top)}	Junction-to-case (top) thermal resistance	68.1	°C/W
R _{θJB}	Junction-to-board thermal resistance	83.4	°C/W
Ψ _{JT}	Junction-to-top characterization parameter	2.2	°C/W
Ψ _{JB}	Junction-to-board characterization parameter	83.4	°C/W
R _{θJC(bot)}	Junction-to-case (bottom) thermal resistance	N/A	

(1) For more information about traditional and new thermal metrics, see the *Semiconductor and C Package Thermal Metrics* application report, [SPRA953](#).

7.5 Electrical Characteristics

over operating free-air temperature range (unless otherwise noted)

PARAMETER		TEST CONDITIONS	MIN	TYP	MAX	UNIT
Power Consumption						
$I_{UNATTACHED_UFP}$	Current consumption in unattached mode when port is unconnected and waiting for connection. ($V_{DD} = 4.5\text{ V}$, $EN_N = L$, $ADDR = NC$, $PORT = L$)			100		μA
I_{ACTIVE_UFP}	Current consumption in active mode. ($V_{DD} = 4.5\text{ V}$, $EN_N = L$, $ADDR = NC$, $PORT = L$)			100		μA
$I_{SHUTDOWN}$	Leakage current when V_{DD} is supplied but the TUSB320 device is not enabled. ($V_{DD} = 4.5\text{ V}$, $EN_N = H$)				1.7	μA
CC1 and CC2 Pins						
R_{CC_DB}	Pulldown resistor when in dead-battery mode.		4.1	5.1	6.1	$\text{k}\Omega$
R_{CC_D}	Pulldown resistor when in UFP or DRP mode.		4.6	5.1	5.6	$\text{k}\Omega$
$V_{TH_UFP_CC_USB}$	Voltage threshold for detecting a DFP attach when configured as a UFP and DFP is advertising default current source capability.		0.15	0.2	0.25	V
$V_{TH_UFP_CC_MED}$	Voltage threshold for detecting a DFP attach when configured as a UFP and DFP is advertising medium (1.5 A) current source capability.		0.61	0.66	0.7	V
$V_{TH_UFP_CC_HIGH}$	Voltage threshold for detecting a DFP attach when configured as a UFP and DFP is advertising high (3 A) current source capability.		1.169	1.23	1.29	V
$V_{TH_DFP_CC_USB}$	Voltage threshold for detecting a UFP attach when configured as a DFP and advertising default current source capability.		1.51	1.6	1.64	V
$V_{TH_DFP_CC_MED}$	Voltage threshold for detecting a UFP attach when configured as a DFP and advertising medium current (1.5 A) source capability.		1.51	1.6	1.64	V
$V_{TH_DFP_CC_HIGH}$	Voltage threshold for detecting a UFP attach when configured as a DFP and advertising high current (3.0 A) source capability.		2.46	2.6	2.74	V
$I_{CC_DEFAULT_P}$	Default mode pullup current source when operating in DFP or DRP mode.		64	80	96	μA
$I_{CC_MED_P}$	Medium (1.5 A) mode pullup current source when operating in DFP or DRP mode.		166	180	194	μA
$I_{CC_HIGH_P}$	High (3 A) mode pullup current source when operating in DFP or DRP mode. ⁽¹⁾		304	330	356	μA
Control Pins: PORT, ADDR, INT/OUT3, EN_N, ID						
V_{IL}	Low-level control signal input voltage, (PORT, ADDR, EN_N)				0.4	V
V_{IM}	Mid-level control signal input voltage (PORT, ADDR)		$0.28 \times V_{DD}$		$0.56 \times V_{DD}$	V
V_{IH}	High-level control signal input voltage (PORT, ADDR, EN_N)		$V_{DD} - 0.3$			V
I_{IH}	High-level input current		-20		20	μA
I_{IL}	Low-level input current		-10		10	μA
R_{EN_N}	Internal pullup resistance for EN_N			1.1		$\text{M}\Omega$
R_{pu}	Internal pullup resistance (PORT, ADDR)			588		$\text{k}\Omega$
R_{pd}	Internal pulldown resistance (PORT, ADDR)			1.1		$\text{M}\Omega$
V_{OL}	Low-level signal output voltage (open-drain) (INT_N/OUT3, ID)	$I_{OL} = -1.6\text{ mA}$			0.4	V
R_{p_ODext}	External pullup resistor on open drain IOs (INT_N/OUT3, ID)			200		$\text{k}\Omega$
R_{p_TLeXt}	Tri-level input external pullup resistor (PORT, ADDR)			4.7		$\text{k}\Omega$
I²C - SDA/OUT1, SCL/OUT2 can operate from 1.8 or 3.3 V ($\pm 10\%$)⁽²⁾						
V_{DD_I2C}	Supply range for I ² C (SDA/OUT1, SCL/OUT2)		1.65	1.8	3.6	V
V_{IH}	High-level signal voltage		1.05			V
V_{IL}	Low-level signal voltage				0.4	V
V_{OL}	Low-level signal output voltage (open drain)	$I_{OL} = -1.6\text{ mA}$			0.4	V

 (1) V_{DD} must be 3.5 V or greater to advertise 3 A current.

 (2) When using 3.3 V for I²C, customer must ensure V_{DD} is above 3.0 V at all times.

Electrical Characteristics (continued)

over operating free-air temperature range (unless otherwise noted)

PARAMETER		TEST CONDITIONS	MIN	TYP	MAX	UNIT
VBUS_DET IO Pins (Connected to System V_{BUS} signal)						
V _{BUS_THR}	V _{BUS} threshold range		2.95	3.30	3.80	V
R _{VBUS}	External resistor between V _{BUS} and VBUS_DET pin		891	900	909	KΩ
R _{VBUS_PD}	Internal pull-down resistance for VBUS_DET			95		KΩ

7.6 Timing Requirements

		MIN	NOM	MAX	UNIT
I²C (SDA, SCL)					
t _{SU:DAT}	Data setup time	250			ns
t _{SU:STA}	Set-up time, SCL to start condition	4.7			μs
t _{HD:STA}	Hold time, (repeated) start condition to SCL	0.4			μs
t _{SU:STO}	Set up time for stop condition	0.4			μs
t _{BUF}	Bus free time between a stop and start condition	4.7			μs
f _{SCL}	SCL clock frequency; I ² C mode for local I ² C control			100	kHz
t _r	Rise time of both SDA and SCL signals			1000	ns
t _f	Fall time of both SDA and SCL signals			300	
C _{bus}	Total capacitive load for each bus line			400	pF

7.7 Switching Characteristics

over operating free-air temperature range (unless otherwise noted)

PARAMETER		TEST CONDITIONS	MIN	TYP	MAX	UNIT
t _{CCCB_DEFAULT}	Power on default of CC1 and CC2 voltage debounce time	DEBOUCE register = 2'b00		133		ms
t _{VBUS_DB}	Debounce of VBUS_DET pin after valid V _{BUS_THR}			2		ms
t _{DRP_DUTY_CYCLE}	Power-on default of percentage of time DRP advertises DFP during a T _{DRP}	DRP_DUTY_CYCLE register = 2'b00		30%		
t _{DRP}	The period TUSB320 in DFP mode completes a DFP to UFP and back advertisement.		50	75	100	ms
t _{I2C_EN}	Time from EN_N low and V _{DD} active to I ² C access available				100	ms
t _{SOFT_RESET}	Soft reset duration		26	49	95	ms

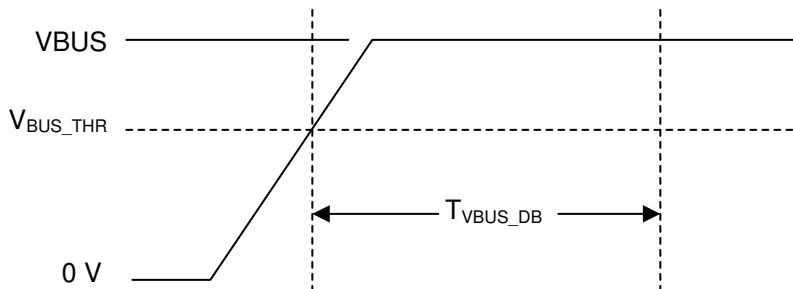

Figure 1. VBUS Detect and Debounce

8 Detailed Description

8.1 Overview

The USB Type-C ecosystem operates around a small form factor connector and cable that is flippable and reversible. Because of the nature of the connector, a scheme is needed to determine the connector orientation. Additional schemes are needed to determine when a USB port is attached and the acting role of the USB port (DFP, UFP, DRP), as well as to communicate Type-C current capabilities. These schemes are implemented over the CC pins according to the USB Type-C specifications. The TUSB320 device provides Configuration Channel (CC) logic for determining USB port attach and detach, role detection, cable orientation, and Type-C current mode. The TUSB320 device also contains several features such as mode configuration and low standby current which make this device ideal for source or sinks in USB2.0 applications.

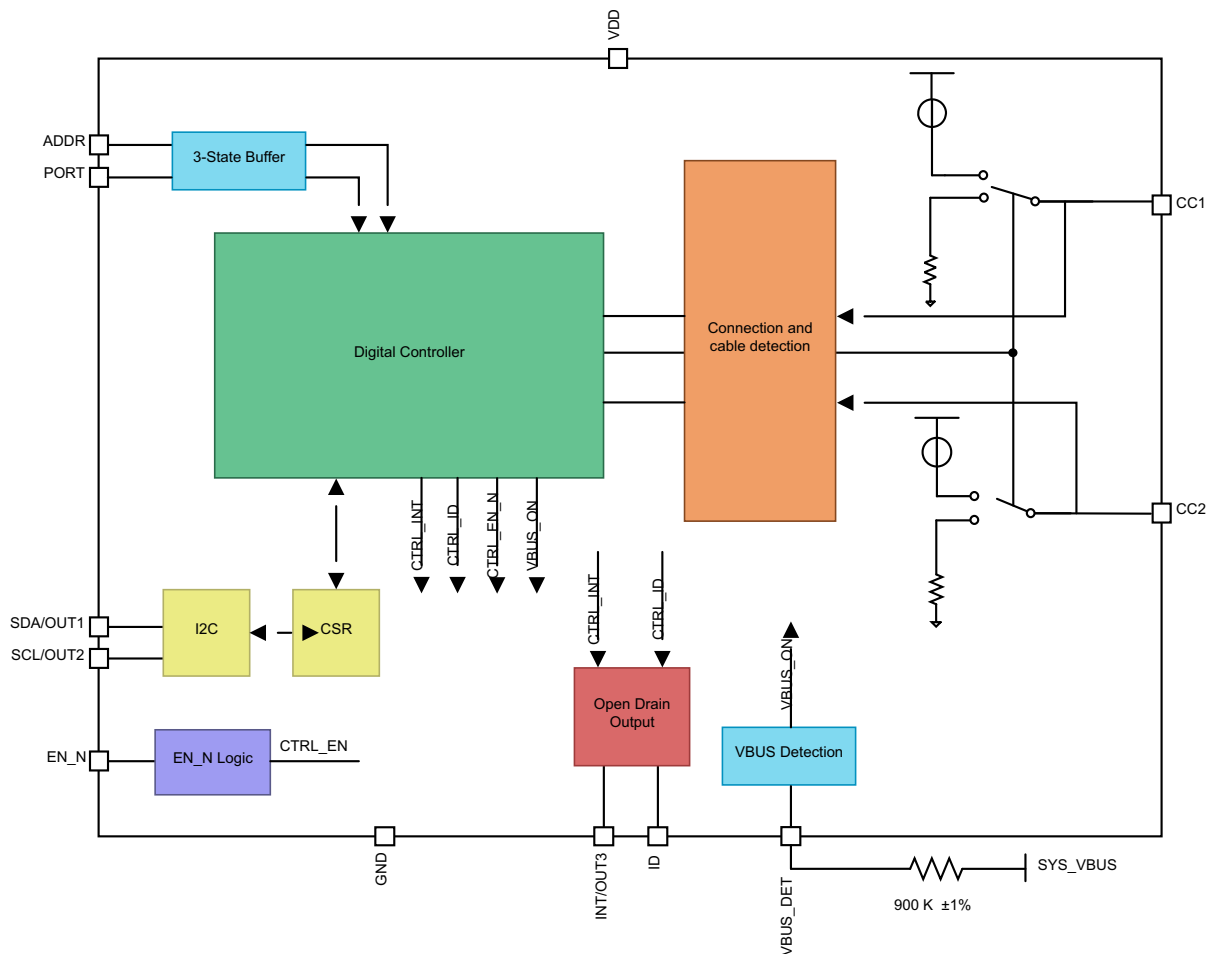

Figure 2. Functional Block Diagram of TUSB320

8.1.1 Cables, Adapters, and Direct Connect Devices

Type-C Specification 1.1 defines several cables, plugs and receptacles to be used to attach ports. The TUSB320 device supports all cables, receptacles, and plugs. The TUSB320 device does not support e-marking.

8.1.1.1 USB Type-C Receptacles and Plugs

Below is list of Type-C receptacles and plugs supported by the TUSB320 device:

- USB Type-C receptacle for USB2.0 platforms and devices
- USB full-featured Type-C plug
- USB2.0 Type-C plug

Overview (continued)

8.1.1.2 USB Type-C Cables

Below is a list of Type-C cables types supported by the TUSB320 device:

- USB full-featured Type-C cable
- USB2.0 Type-C cable with USB2.0 plug
- Captive cable with either a USB full-featured plug or USB2.0 plug

8.1.1.3 Legacy Cables and Adapters

The TUSB320 device supports legacy cable adapters as defined by the Type-C Specification. The cable adapter must correspond to the mode configuration of the TUSB320 device.

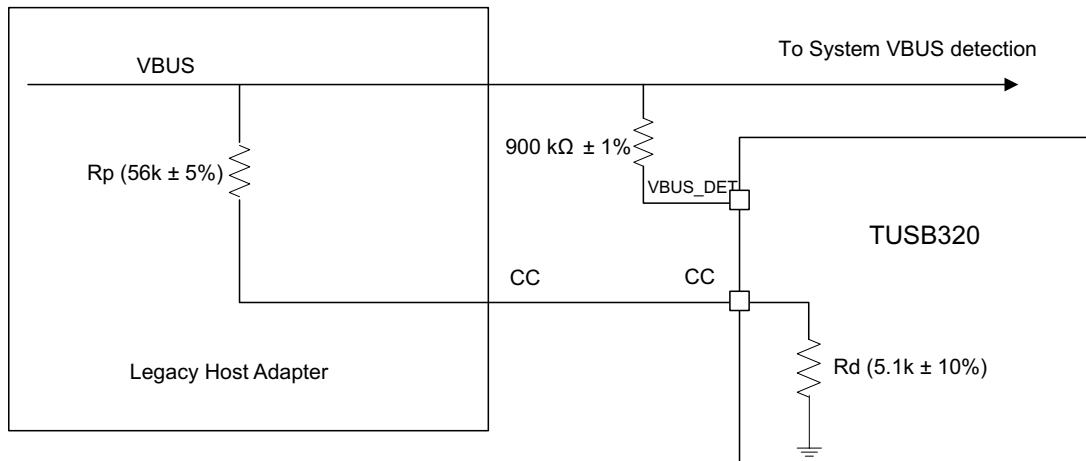

Figure 3. Legacy Adapter Implementation Circuit

8.1.1.4 Direct Connect Devices

The TUSB320 device supports the attaching and detaching of a direct-connect device.

8.1.1.5 Audio Adapters

Additionally, the TUSB320 device supports audio adapters for audio accessory mode, including:

- Passive Audio Adapter
- Charge Through Audio Adapter

8.2 Feature Description

8.2.1 Port Role Configuration

The TUSB320 device can be configured as a downstream facing port (DFP), upstream facing port (UFP), or dualrole port (DRP) using the tri-level PORT pin. The PORT pin should be pulled high to V_{DD} using a pullup resistance, low to GND or left as floated on the PCB to achieve the desired mode. This flexibility allows the TUSB320 device to be used in a variety of applications. The TUSB320 device samples the PORT pin after reset and maintains the desired mode until the TUSB320 device is reset again. [Table 1](#) lists the supported features in each mode:

Feature Description (continued)
Table 1. Supported Features for the TUSB320 Device by Mode

PORT PIN	HIGH (DFP ONLY)	LOW (UFP ONLY)	NC (DRP)
SUPPORTED FEATURES			
Port attach and detach	Yes	Yes	Yes
Cable orientation (through I ² C)	Yes	Yes	Yes
Current advertisement	Yes	-	Yes (DFP)
Current detection	-	Yes	Yes (UFP)
Accessory modes (audio and debug)	Yes	-	Yes
Active cable detection	Yes	-	Yes (DFP)
I ² C / GPIO	Yes	Yes	Yes
Legacy cables	Yes	Yes	Yes
V _{BUS} detection	-	Yes	Yes (UFP)

8.2.1.1 Downstream Facing Port (DFP) - Source

The TUSB320 device can be configured as a DFP only by pulling the PORT pin high through a resistance to V_{DD}. In DFP mode, the TUSB320 device constantly presents R_{ps} on both CC. In DFP mode, the TUSB320 device initially advertises default USB Type-C current. The Type-C current can be adjusted through I²C if the system needs to increase the amount advertised. The TUSB320 device adjusts the R_{ps} to match the desired Type-C current advertisement. In GPIO mode, the TUSB320 device only advertises default Type-C current.

When configured as a DFP, the TUSB320 can operate with older USB Type-C 1.0 devices except for a USB Type-C 1.0 DRP device. The TUSB320 can not operate with a USB Type-C 1.0 DRP device. This limitation is a result of a backwards compatibility problem between USB Type-C 1.1 DFP and a USB Type-C 1.0 DRP.

8.2.1.2 Upstream Facing Port (UFP) - Sink

The TUSB320 device can be configured as a UFP only by pulling the PORT pin low to GND. In UFP mode, the TUSB320 device constantly presents pull-down resistors (R_d) on both CC pins. The TUSB320 device monitors the CC pins for the voltage level corresponding to the Type-C mode current advertisement by the connected DFP. The TUSB320 device debounces the CC pins and wait for V_{BUS} detection before successfully attaching. As a UFP, the TUSB320 device detects and communicates the advertised current level of the DFP to the system through the OUT1 and OUT2 GPIOs (if in GPIO mode) or through the I²C CURRENT_MODE_DETECT register one time in the Attached.SNK state.

After initial connection, the advertised current by the connected DFP could change due to changes in its system power resource. For example, a DFP could advertise high current on initial connection but then decide to reduce to default current because user removed external power adapter from their notebook. Because the TUSB320 will only advertise on OUT1 and OUT2 the initial advertised current, it is recommend to monitor the advertised current through the TUSB320's I2C interface from the CURRENT_MODE_DETECT register. System software must periodically perform a I2C_SOFT_RESET in order for the CURRENT_MODE_DETECT register to be updated based on the state of the CC pins.

8.2.1.3 Dual Role Port (DRP)

The TUSB320 device can be configured to operate as a DRP when the PORT pin is left floated on the PCB. In DRP mode, the TUSB320 device toggles between operating as a DFP and a UFP. When functioning as a DFP in DRP mode, the TUSB320 device complies with all operations as defined for a DFP according to the Type-C Specification. When presenting as a UFP in DRP mode, the TUSB320 device operates as defined for a UFP according to the Type-C Specification.

8.2.2 Type-C Current Mode

When a valid cable detection and attach have been completed, the DFP has the option to advertise the level of Type-C current a UFP can sink. The default current advertisement for the TUSB320 device is 500 mA (for USB2.0) or 900 mA (for USB3.1). If a higher level of current is available, the I²C registers can be written to provide medium current at 1.5 A or high current at 3 A. When the CURRENT_MODE_ADVERTISE register has been written to advertise higher than default current, the DFP adjusts the Rps for the specified current level. If a DFP advertises 3 A, it ensures that the V_{DD} of the TUSB320 device is 3.5 V or greater. [Table 2](#) lists the Type-C current advertisements in GPIO or I²C modes.

Table 2. Type-C Current Advertisement for GPIO and I²C Modes

TYPE-C CURRENT		GPIO MODE (ADDR PIN IN NC)		I ² C MODE (ADDR PIN H, L)	
		UFP (PORT PIN L)	DFP (PORT PIN H)	UFP	DFP
Default	500 mA (USB2.0)	Current mode detected and output through OUT1 / OUT2	Only advertisement	Current mode detected and read through I ² C register	I ² C register default is 500 or 900 mA
	900 mA (USB3.1)				
	Medium - 1.5 A		N/A		Advertisement selected through writing I ² C register
	High - 3 A				

8.2.3 Accessory Support

The TUSB320 device supports audio and debug accessories in DFP mode and DRP mode. Audio and debug accessory support is provided through reading of I²C registers. Audio accessory is also supported through GPIO mode with INT_N/OUT3 pin (audio accessory is detected when INT_N/OUT3 pin is low).

8.2.3.1 Audio Accessory

Audio accessory mode is supported through two types of adapters. First, the passive audio adapter can be used to convert the Type-C connector into an audio port. In order to effectively detect the passive audio adapter, the TUSB320 device must detect a resistance < R_a on both of the CC pins.

Secondly, a charge through audio adapter may be used. The primary difference between a passive and charge through adapter is that the charge through adapter supplies 500 mA of current over V_{BUS}. The charge through adapter contains a receptacle and a plug. The plug acts as a DFP and supply V_{BUS} when the plug detects a connection.

When the TUSB320 device is configured in GPIO mode, OUT3 pin determines if an audio accessory is connected. When an audio accessory is detected, the OUT3 pin is pulled low.

8.2.3.2 Debug Accessory

Debug is an additional state supported by USB Type-C. The specification does not define a specific user scenario for this state, but it is important because the end user could use debug accessory mode to enter a test state for production specific to the application. Charge through debug accessory is not supported by TUSB320 when in DRP or UFP mode.

8.2.4 I²C and GPIO Control

The TUSB320 device can be configured for I²C communication or GPIO outputs using the ADDR pin. The ADDR pin is a tri-level control pin. When the ADDR pin is left floating (NC), the TUSB320 device is in GPIO output mode. When the ADDR pin is pulled high or pulled low, the TUSB320 device is in I²C mode.

All outputs for the TUSB320 device are open drain configuration.

The OUT1 and OUT2 pins are used to output the Type-C current mode when in GPIO mode. Additionally, the OUT3 pin is used to communicate the audio accessory mode in GPIO mode. [Table 3](#) lists the output pin settings. See for more information.

Table 3. Simplified Operation for OUT1 and OUT2

OUT1	OUT2	ADVERTISEMENT
H	H	Default Current in Unattached State
H	L	Default Current in Attached State
L	H	Medium Current (1.5 A) in Attached State
L	L	High Current (3.0 A) in Attached State

When operating in I²C mode, the TUSB320 device uses the SCL and SDA lines for clock and data and the INT_N pin to communicate a change in I²C registers, or an interrupt, to the system. The INT_N pin is pulled low when the TUSB320 device updates the registers with new information. The INT_N pin is open drain. The INTERRUPT_STATUS register should be set when the INT_N pin is pulled low. To clear the INTERRUPT_STATUS register, the end user writes to I²C.

When operating in GPIO mode, the OUT3 pin is used in place of the INT_N pin to determine if an audio accessory is detected and attached. The OUT3 pin is pulled low when an audio accessory is detected.

NOTE

When using the 3.3 V supply for I²C, the end user must ensure that the V_{DD} is 3 V and above. Otherwise the I²C may back power the device.

8.2.5 V_{BUS} Detection

The TUSB320 device supports V_{BUS} detection according to the Type-C Specification. V_{BUS} detection is used to determine the attachment and detachment of a UFP and to determine the entering and exiting of accessory modes. V_{BUS} detection is also used to successfully resolve the role in DRP mode.

The system V_{BUS} voltage must be routed through a 900-kΩ resistor to the VBUS_DET pin on the TUSB320 device if the PORT pin is configured as a DRP or a UFP. If the TUSB320 device is configured as a DFP and only ever used in DFP mode, the VBUS_DET pin can be left unconnected.

8.3 Device Functional Modes

The TUSB320 device has four functional modes. [Table 4](#) lists these modes:

Table 4. USB Type-C States According to TUSB320 Functional Modes

MODES	GENERAL BEHAVIOR	PORT PIN	STATES ⁽¹⁾
Unattached	USB port unattached. ID, PORT operational. I ² C on. CC pins configure according to PORT pin.	UFP	Unattached.SNK
			AttachWait.SNK
		DRP	Toggle Unattached.SNK → Unattached.SRC
			AttachedWait.SRC or AttachedWait.SNK
		DFP	Unattached.SRC
Active	USB port attached. All GPIOs operational. I ² C on.	UFP	Attached.SNK
			Attached.SNK
		DRP	Attached.SRC
			Audio accessory
			Debug accessory
		DFP	Attached.SRC
			Audio accessory
			Debug accessory
		Dead battery	No operation. V _{DD} not available.
Shutdown	V _{DD} available. EN_N pin high.	UFP/DRP/DFP	Default device state to UFP/SNK with Rd.

(1) Required; not in sequential order.

8.3.1 Unattached Mode

Unattached mode is the primary mode of operation for the TUSB320 device, because a USB port can be unattached for a lengthy period of time. In unattached mode, V_{DD} is available, and all IOs and I²C are operational. After the TUSB320 device is powered up, the part enters unattached mode until a successful attach has been determined. Initially, right after power up, the TUSB320 device comes up as an Unattached.SNK. The TUSB320 device checks the PORT pin and operates according to the mode configuration. The TUSB320 device toggles between the UFP and the DFP if configured as a DRP. In unattached mode, I²C can be used to change the mode configuration or port role if the board configuration of the PORT pin is not the desired mode. Writing to the I²C MODE_SELECT register can override the PORT pin only in unattached mode. The PORT pin is only sampled at reset or power up. I²C must be used after reset to change the device mode configuration.

8.3.2 Active Mode

Active mode is defined as the port being attached. In active mode, all GPIOs are operational, and I²C is read / write (R/W). When in active mode, the TUSB320 device communicates to the AP that the USB port is attached. This happens through the ID pin if TUSB320 is configured as a DFP or DRP connect as source. If TUSB320 is configured as a UFP or a DRP connected as a sink, the OUT1/OUT2 and INT_N/OUT3 pins are used. The TUSB320 device exits active mode under the following conditions:

- Cable unplug
- V_{BUS} removal if attached as a UFP
- Dead battery; system battery or supply is removed
- EN_N pin floated or pulled high

During active mode, I²C cannot be used to change the mode configuration. This can only be done if TUSB320 is in unattached state.

8.3.3 Dead Battery Mode

During dead battery mode, V_{DD} is not available. CC pins always default to pulldown resistors in dead battery mode. Dead battery mode means:

- TUSB320 in UFP with $5.1\text{-k}\Omega \pm 20\%$ Rd; cable connected and providing charge
- TUSB320 in UFP with $5.1\text{-k}\Omega \pm 20\%$ Rd; nothing connected (application could be off or have a discharged battery)

Upon exiting dead battery mode (V_{DD} is active), the software must perform the following sequence in order for Rp to be presented on both CC pins:

1. Write a 0x04 to I²C address 0x45.
2. Wait 30ms.
3. Write a 0x00 to I²C address 0x45.

Between steps 1 and 3, the status flags will be set. The software must ignore these flags when performing the three steps.

NOTE

When V_{DD} is off, the TUSB320 non-failsafe pins (VBUS_DET, ADDR, PORT, ID, OUT[3:1] pins) could back-drive the TUSB320 device if not handled properly. When necessary to pull these pins up, it is recommended to pullup PORT, ADDR, INT_N/OUT3, and ID to the device's V_{DD} supply. The VBUS_DET must be pulled up to V_{BUS} through a 900-k Ω resistor.

8.3.4 Shutdown Mode

Shutdown mode for TUSB320 device is defined as follows:

- Supply voltage available and EN_N pin is pulled high.
- EN_N pin has internal pullup resistor.
- The TUSB320 device is off, but still maintains the Rd on the CC pins

8.4 Programming

For further programmability, the TUSB320 device can be controlled using I²C. The TUSB320 device local I²C interface is available for reading/writing after T_{I²C_EN} when the device is powered up. The SCL and SDA terminals are used for I²C clock and I²C data respectively. If I²C is the preferred method of control, the ADDR pin must be set accordingly.

Table 5. TUSB320 I²C Addresses

TUSB320 I ² C Target Address								
ADDR pin	Bit 7 (MSB)	Bit 6	Bit 5	Bit 4	Bit 3	Bit 2	Bit 1	Bit 0 (W/R)
H	1	1	0	0	0	0	1	0/1
L	1	1	0	0	0	0	0	0/1

The following procedure should be followed to write to TUSB320 I²C registers:

1. The master initiates a write operation by generating a start condition (S), followed by the TUSB320 7-bit address and a zero-value R/W bit to indicate a write cycle
2. The TUSB320 device acknowledges the address cycle
3. The master presents the sub-address (I²C register within the TUSB320 device) to be written, consisting of one byte of data, MSB-first
4. The TUSB320 device acknowledges the sub-address cycle
5. The master presents the first byte of data to be written to the I²C register
6. The TUSB320 device acknowledges the byte transfer
7. The master may continue presenting additional bytes of data to be written, with each byte transfer completing with an acknowledge from the TUSB320 device
8. The master terminates the write operation by generating a stop condition (P)

The following procedure should be followed to read the TUSB320 I²C registers:

1. The master initiates a read operation by generating a start condition (S), followed by the TUSB320 7-bit address and a one-value R/W bit to indicate a read cycle
2. The TUSB320 device acknowledges the address cycle
3. The TUSB320 device transmits the contents of the memory registers MSB-first starting at register 00h or last read sub-address+1. If a write to the T I²C register occurred prior to the read, then the TUSB320 device starts at the sub-address specified in the write.
4. The TUSB320 device waits for either an acknowledge (ACK) or a not-acknowledge (NACK) from the master after each byte transfer; the I²C master acknowledges reception of each data byte transfer
5. If an ACK is received, the TUSB320 device transmits the next byte of data
6. The master terminates the read operation by generating a stop condition (P)

The following procedure should be followed for setting a starting sub-address for I²C reads:

1. The master initiates a write operation by generating a start condition (S), followed by the TUSB320 7-bit address and a zero-value R/W bit to indicate a read cycle
2. The TUSB320 device acknowledges the address cycle
3. The master presents the sub-address (I²C register within the TUSB320 device) to be read, consisting of one byte of data, MSB-first
4. The TUSB320 device acknowledges the sub-address cycle
5. The master terminates the read operation by generating a stop condition (P)

NOTE

If no sub-addressing is included for the read procedure, then the reads start at register offset 00h and continue byte-by-byte through the registers until the I²C master terminates the read operation. If a I²C address write occurred prior to the read, then the reads start at the sub-address specified by the address write.

8.5 Register Maps

Table 6. CSR Registers

ACCESS TAG	NAME	MEANING
R	Read	The field may be read by software.
W	Write	The field may be written by software.
S	Set	The field may be set by a write of one. Writes of zeros to the field have no effect.
C	Clear	The field may be cleared by a write of one. Writes of zeros to the field have no effect.
U	Update	Hardware may autonomously update this field.
NA	No Access	Not accessible or not applicable.

Table 7. CSR Registers Bit Address and Description

ADDRESS	BIT(S)	BIT NAME	DESCRIPTION	ACCESS
0x00 – 0x07	7:0	DEVICE_ID	For the TUSB320 device these fields return a string of ASCII characters returning TUSB320 Addresses 0x07 - 0x00 = {0x00 0x54 0x55 0x53 0x42 0x33 0x32 0x30}	R
0x08	7:6	CURRENT_MODE_ADVERTISE	These bits are programmed by the application to raise the current advertisement from default. 00 – Default (500 mA / 900 mA) initial value at startup 01 – Mid (1.5 A) 10 – High (3 A) 11 – Reserved	RW
	5:4	CURRENT_MODE_DETECT	These bits are set when a UFP determines the Type-C Current mode. 00 – Default (value at start up) 01 – Medium 10 – Charge through accessory – 500 mA 11 – High	RU
	3:1	ACCESSORY_CONNECTED	These bits are read by the application to determine if an accessory was attached. 000 – No accessory attached (default) 001 – Reserved 010 – Reserved 011 – Reserved 100 – Audio accessory 101 – Audio charged thru accessory 110 – Debug accessory 111 – Reserved	RU
	0	ACTIVE_CABLE_DETECTION	This flag indicates that an active cable has been plugged into the Type-C connector. When this field is set, an active cable is detected.	RU

Table 7. CSR Registers Bit Address and Description (continued)

ADDRESS	BIT(S)	BIT NAME	DESCRIPTION	ACCESS
0x09	7:6	ATTACHED_STATE	This is an additional method to communicate attach other than the ID pin. These bits can be read by the application to determine what was attached. 00 – Not attached (default) 01 – Attached.SRC (DFP) 10 – Attached.SNK (UFP) 11 – Attached to an accessory	RU
	5	CABLE_DIR	Cable orientation. The application can read these bits for cable orientation information. 0 – CC1 1 – CC2 (default)	RU
	4	INTERRUPT_STATUS	The INT pin is pulled low whenever a CSR changes. When a CSR change has occurred this bit should be held at 1 until the application clears it. 0 – Clear 1 – Interrupt (When INT_N is pulled low, this bit will be 1. This bit is 1 whenever any CSR are changed)	RCU
	3		Reserved	R
	2:1	DRP_DUTY_CYCLE	Percentage of time that a DRP advertises DFP during tDRP 00 – 30% (default) 01 – 40% 10 – 50% 11 – 60%	RW
	0		Reserved	R

Table 7. CSR Registers Bit Address and Description (continued)

ADDRESS	BIT(S)	BIT NAME	DESCRIPTION	ACCESS
0x0A	7:6	DEBOUNCE	The nominal amount of time the TUSB320 device debounces the voltages on the CC pins. 00 – 133ms (default) 01 – 116ms 10 – 151ms 11 – 168ms	RW
	5:4	MODE_SELECT	This register can be written to set the TUSB320 device mode operation. The ADDR pin must be set to I ² C mode. If the default is maintained, the TUSB320 device operates according to the PORT pin levels and modes. The MODE_SELECT can only be changed when in the unattached state. 00 – Maintain mode according to PORT pin selection (default) 01 – UFP mode (unattached.SNK) 10 – DFP mode(unattached.SRC) 11 – DRP mode(start from unattached.SNK)	RW
	3	I ² C_SOFT_RESET	This resets the digital logic. The bit is self-clearing. A write of 1 starts the reset. The following registers maybe affected after setting this bit: CURRENT_MODE_DETECT ACTIVE_CABLE_DETECTION ACCESSORY_CONNECTED ATTACHED_STATE CABLE_DIR	RSU
	2:1		Reserved	R
	0		Reserved	R
0x45	7:3		Reserved	R
	2	DISABLE_RD_RP	When this field is set, Rd and Rp are disabled. 0 – Normal operation (default) 1 – Disable Rd and Rp	RW
	1:0		Reserved. For TI internal use only. Do not change default value.	RW

9 Application and Implementation

NOTE

Information in the following applications sections is not part of the TI component specification, and TI does not warrant its accuracy or completeness. TI's customers are responsible for determining suitability of components for their purposes. Customers should validate and test their design implementation to confirm system functionality.

9.1 Application Information

The TUSB320 device is a Type-C configuration channel logic and port controller. The TUSB320 device can detect when a Type-C device is attached, what type of device is attached, the orientation of the cable, and power capabilities (both detection and broadcast). The TUSB320 device can be used in a source application (DFP) or in a sink application (UFP).

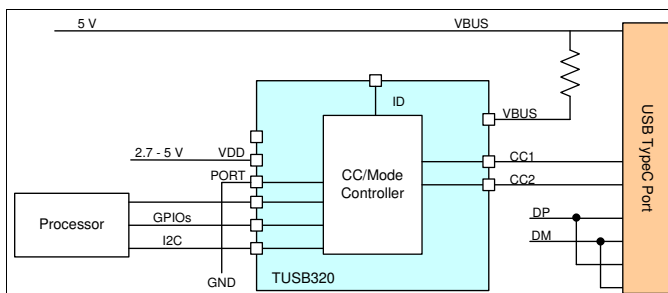

Figure 4. TUSB320 in UFP Mode Supporting Default Implementation

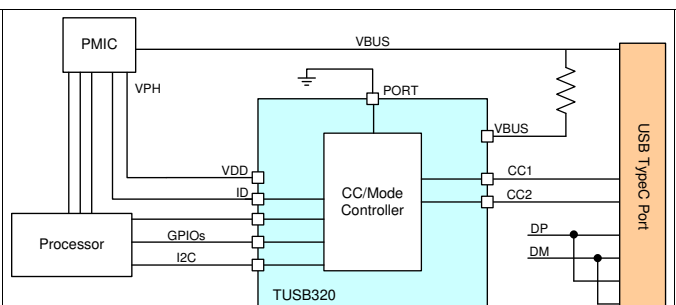

Figure 5. TUSB320 in UFP Mode Supporting Advanced Power Delivery

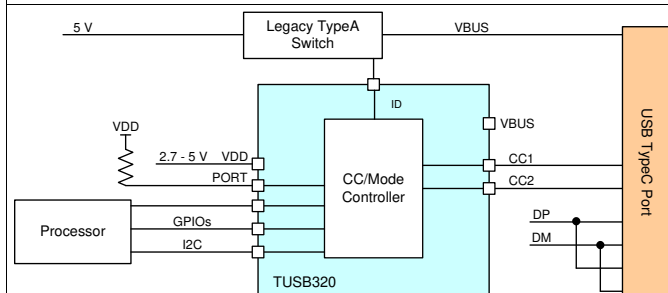

Figure 6. TUSB320 in DFP Mode Supporting Default Implementation

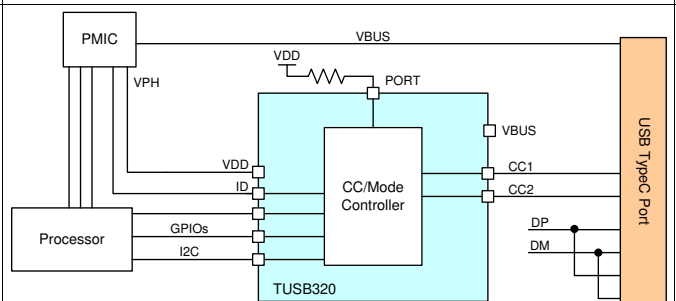

Figure 7. TUSB320 in DFP Mode Supporting Advanced Power Delivery

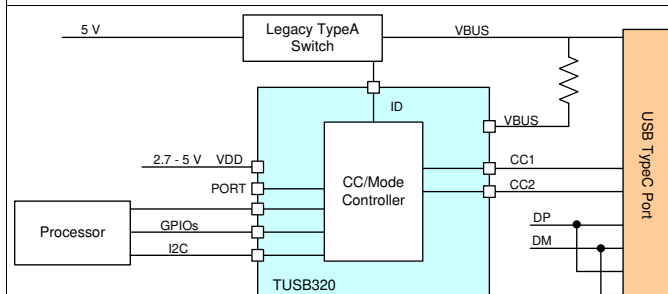

Figure 8. TUSB320 in DRP Mode Supporting Default Implementation

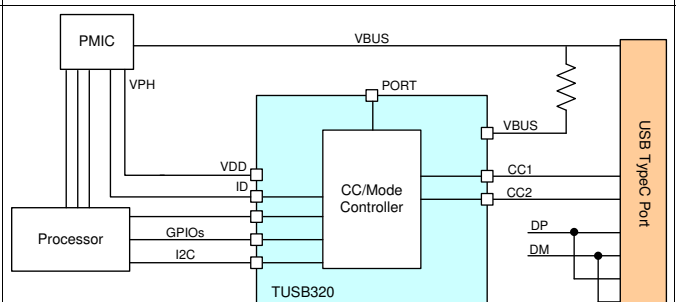

Figure 9. TUSB320 in DRP Mode Supporting Advanced Power Delivery

9.2 Typical Application

9.2.1 DRP in I²C Mode

Figure 10 shows the TUSB320 device configured as a DRP in I²C mode.

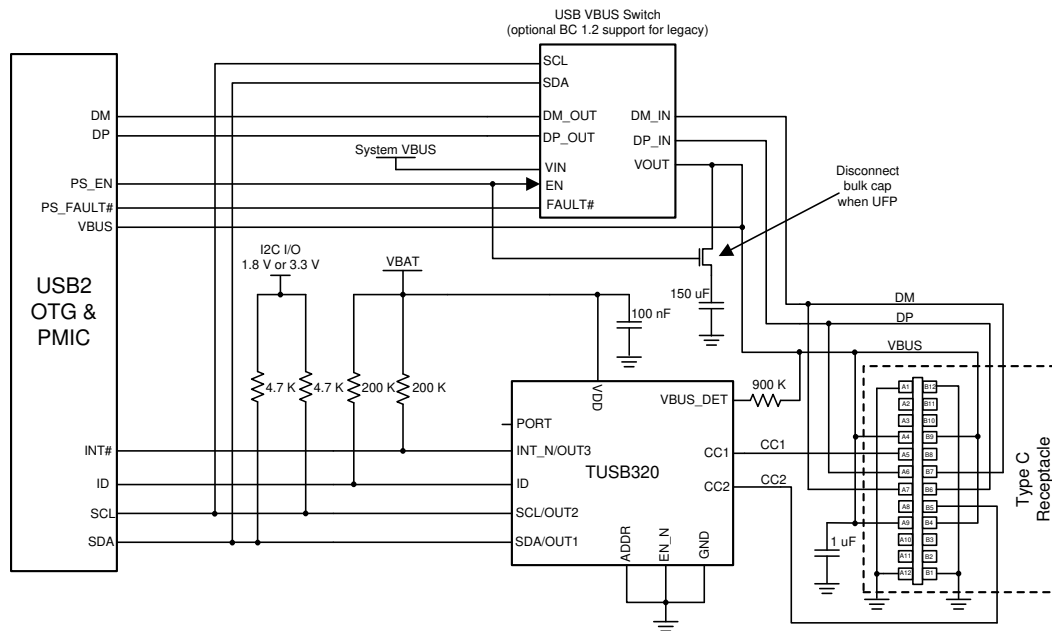

Figure 10. DRP in I²C Mode Schematic

9.2.1.1 Design Requirements

For this design example, use the parameters listed in Table 8:

Table 8. Design Requirements for DRP in I²C Mode

DESIGN PARAMETER	VALUE
V _{DD} (2.75 V to 5 V)	VBAT (less than 5 V)
Mode (I ² C or GPIO)	I ² C ADDR pin must be pulled down or pulled up
I ² C address (0x61 or 0x60)	0x60 ADDR pin must be pulled low or tied to GND
Type-C port type (UFP, DFP, or DRP)	DRP PORT pin is NC
Shutdown support (EN_N control)	No

9.2.1.2 Detailed Design Procedure

The TUSB320 device supports a V_{DD} in the range of 2.75 V to 5 V. In this particular use case, VBAT which must be in the required V_{DD} range is connected to the V_{DD} pin. A 100-nF capacitor is placed near V_{DD}.

The TUSB320 device is placed into I²C mode by either pulling the ADDR pin high or low. In this case, the ADDR pin is tied to GND which results in a I²C address of 0x60. The SDA and SCL must be pulled up to either 1.8 V or 3.3 V. When pulled up to 3.3 V, the V_{DD} supply must be at least 3 V to keep from back-driving the I²C interface.

The TUSB320 device can enter shutdown mode by pulling the EN_N pin high, which puts the TUSB320 device into a low power state. In this case, external control of the EN_N pin is not implemented and therefore the EN_N pin is tied to GND.

The INT_N/OUT3 pin is used to notify the PMIC when a change in the TUSB320 I²C registers occurs. This pin is an open drain output and requires an external pullup resistor. The pin should be pulled up to V_{DD} using a 200-kΩ resistor.

The ID pin is used to indicate when a connection has occurred if the TUSB320 device is a DFP while configured for DRP. An OTG USB controller can use this pin to determine when to operate as a USB Host or USB Device. When this pin is driven low, the OTG USB controller functions as a host and then enables V_{BUS} . The Type-C standard requires that a DFP not enable V_{BUS} until it is in the Attached.SRC state. If the ID pin is not low but V_{BUS} is detected, then OTG USB controller functions as a device. The ID pin is open drain output and requires an external pullup resistor. It should be pulled up to V_{DD} using a 200-k Ω resistor.

The Type-C port mode is determined by the state of the PORT pin. When the PORT pin is not connected, the TUSB320 device is in DRP mode. The Type-C port mode can also be controlled by the MODE_SELECT register through the I²C interface when the TUSB320 device is in the unattached state.

The VBUS_DET pin must be connected through a 900-k Ω resistor to V_{BUS} on the Type-C that is connected. This large resistor is required to protect the TUSB320 device from large V_{BUS} voltage that is possible in present day systems. This resistor along with internal pulldown keeps the voltage observed by the TUSB320 device in the recommended range.

The USB2 specification requires the bulk capacitance on V_{BUS} based on UFP or DFP. When operating the TUSB320 device in a DRP mode, it alternates between UFP and DFP. If the TUSB320 device connects as a UFP, the large bulk capacitance must be removed. The FET in Figure 10 performs this task.

Table 9. USB2 Bulk Capacitance Requirements

PORT CONFIGURATION	MIN	MAX	UNIT
Downstream facing port (DFP)	120		μ F
Upstream facing port (UFP)	1	10	μ F

9.2.1.3 Application Curves

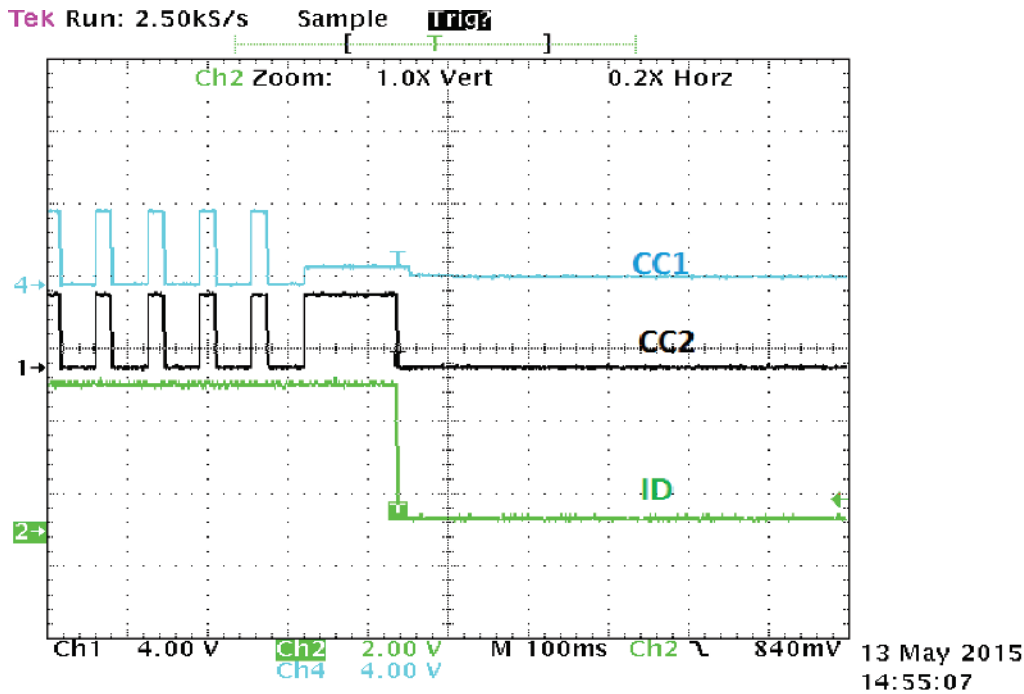

Figure 11. Application Curve for DRP in I²C Mode

9.2.2 DFP in I²C Mode

Figure 12 shows the TUSB320 device configured as a DFP in I²C mode.

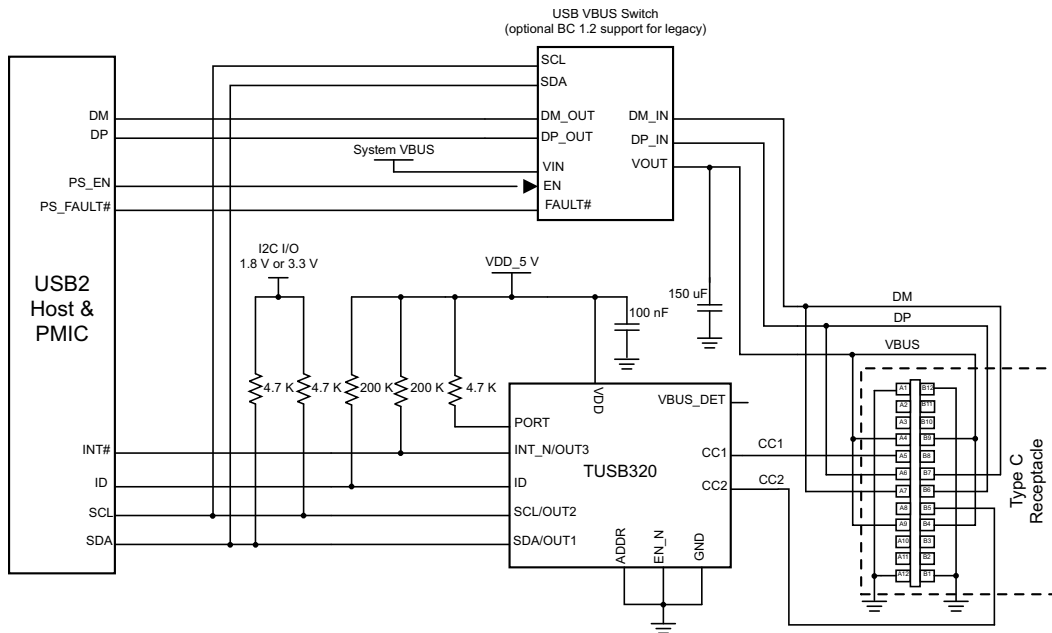

Figure 12. DFP in I²C Mode Schematic

9.2.2.1 Design Requirements

For this design example, use the parameters listed in Table 10:

Table 10. Design Requirements for DFP in I²C Mode

DESIGN PARAMETER	VALUE
V _{DD} (2.75 V to 5 V)	5 V
Mode (I ² C or GPIO)	I ² C ADDR pin must be pulled down or pulled up
I ² C address (0x61 or 0x60)	0x60 ADDR pin must be pulled low or tied to GND
Type-C port type (UFP, DFP, or DRP)	DFP PORT pin is pulled up
Shutdown support (EN_N Control)	No

9.2.2.2 Detailed Design Procedure

The TUSB320 device supports a V_{DD} in the range of 2.75 V to 5 V. In this particular case, V_{DD} is set to 5 V. A 100-nF capacitor is placed near V_{DD}.

The TUSB320 device is placed into I²C mode by either pulling the ADDR pin high or low. In this particular case, the ADDR pin is tied to GND which results in a I²C address of 0x60. The SDA and SCL must be pulled up to either 1.8 V or 3.3 V. When pulled up to 3.3 V, the V_{DD} supply must be at least 3 V to keep from back-driving the I²C interface.

The TUSB320 device can enter shutdown mode by pulling the EN_N pin high, which puts the TUSB320 device into a low power state. In this case, external control of the EN_N pin is not implemented and therefore the EN_N pin is tied to GND.

The INT_N/OUT3 pin is used to notify the PMIC when a change in the TUSB320 I²C registers occurs. This pin is an open drain output and requires an external pullup resistor. The pin should be pulled up to V_{DD} using a 200-kΩ resistor.

The Type-C port mode is determined by the state of the PORT pin. When the PORT pin is pulled high, the TUSB320 device is in DFP mode. The Type-C port mode can also be controlled by the MODE_SELECT register through the I²C interface when the TUSB320 device is in the unattached state.

The VBUS_DET pin must be connected through a 900-kΩ resistor to V_{BUS} on the Type-C that is connected. This large resistor is required to protect the TUSB320 device from large V_{BUS} voltage that is possible in present day systems. This resistor along with internal pulldown keeps the voltage observed by the TUSB320 device in the recommended range.

The USB2 specification requires the bulk capacitance on V_{BUS} based on UFP or DFP. When operating the TUSB320 device in a DFP mode, a bulk capacitance of at least 120μF is required. In this particular case, a 150-μF capacitor was chosen.

9.2.2.3 Application Curves

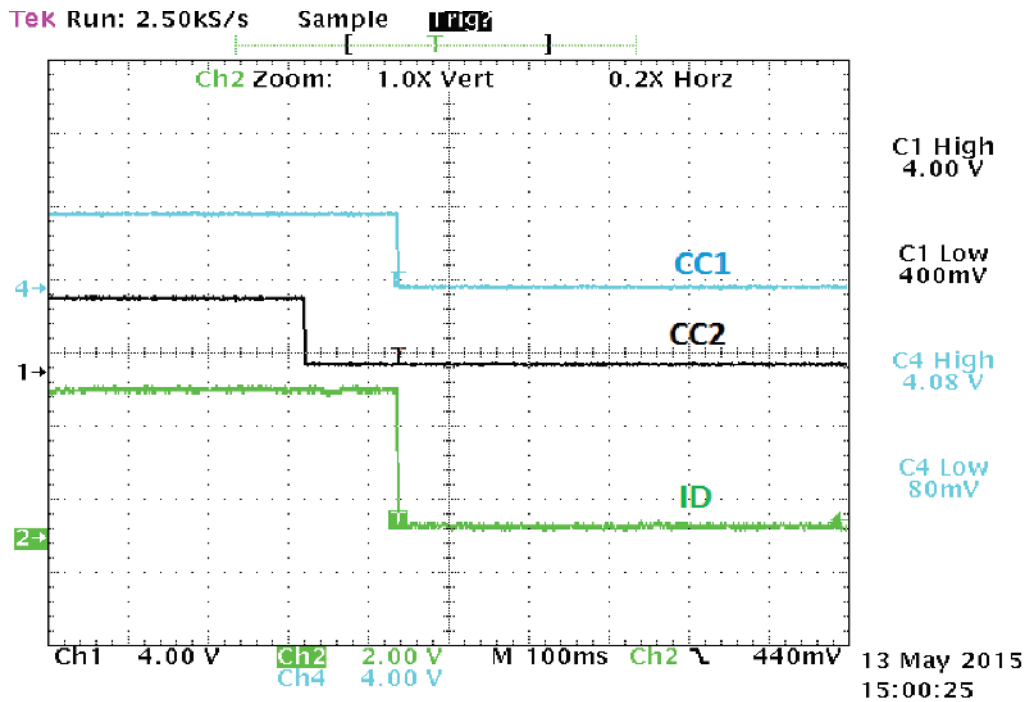

Figure 13. Application Curve for DFP in I²C Mode

9.2.3 UFP in I²C Mode

Figure 14 shows the TUSB320 device configured as a DFP in I²C mode.

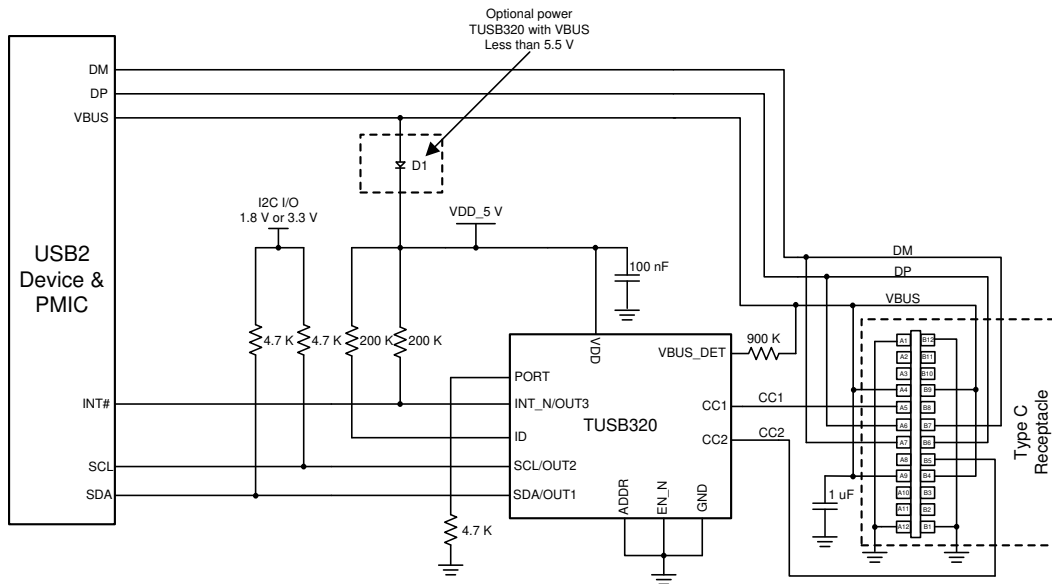

Figure 14. UFP in I²C Mode Schematic

9.2.3.1 Design Requirements

For this design example, use the parameters listed in Table 11:

Table 11. Design Requirements for UFP in I²C Mode

DESIGN PARAMETER	VALUE
V _{DD} (2.75 V to 5 V)	5 V
Mode (I ² C or GPIO)	I ² C ADDR pin must be pulled down or pulled up
I ² C address (0x61 or 0x60)	0x60 ADDR pin must be pulled low or tied to GND
Type-C port type (UFP, DFP, or DRP)	UFP PORT pin is pulled down
Shutdown support (EN_N control)	No

9.2.3.2 Detailed Design Procedure

The TUSB320 device supports a V_{DD} in the range of 2.75 V to 5 V. In this particular case, V_{DD} is set to 5 V. A 100-nF capacitor is placed near V_{DD}. If V_{BUS} is guaranteed to be less than 5.5 V, powering the TUSB320 device through a diode can be implemented.

The TUSB320 device is placed into I²C mode by either pulling the ADDR pin high or low. In this case, the ADDR pin is tied to GND which results in a I²C address of 0x60. The SDA and SCL must be pulled up to either 1.8 V or 3.3 V. When pulled up to 3.3 V, the V_{DD} supply must be at least 3 V to keep from back-driving the I²C interface.

The TUSB320 device can enter shutdown mode by pulling the EN_N pin high, which puts the TUSB320 device into a low power state. In this case, external control of the EN_N pin is not implemented and therefore the EN_N pin is tied to GND.

The INT_N/OUT3 pin is used to notify the PMIC when a change in the TUSB320 I²C registers occurs. This pin is an open drain output and requires an external pullup resistor. The pin should be pulled up to V_{DD} using a 200-kΩ resistor.

The Type-C port mode is determined by the state of the PORT pin. When the PORT pin is pulled low, the TUSB320 device is in UFP mode. The Type-C port mode can also be controlled by the MODE_SELECT register through the I²C interface when the TUSB320 device is in the unattached state.

The VBUS_DET pin must be connected through a 900-k Ω resistor to V_{BUS} on the Type-C that is connected. This large resistor is required to protect the TUSB320 device from large V_{BUS} voltage that is possible in present day systems. This resistor along with internal pulldown keeps the voltage observed by the TUSB320 device in the recommended range.

The USB2 specification requires the bulk capacitance on V_{BUS} based on UFP or DFP. When operating the TUSB320 device in a UFP mode, a bulk capacitance between 1 to 10 μ F is required. In this particular case, a 1- μ F capacitor was chosen.

9.2.3.3 Application Curves

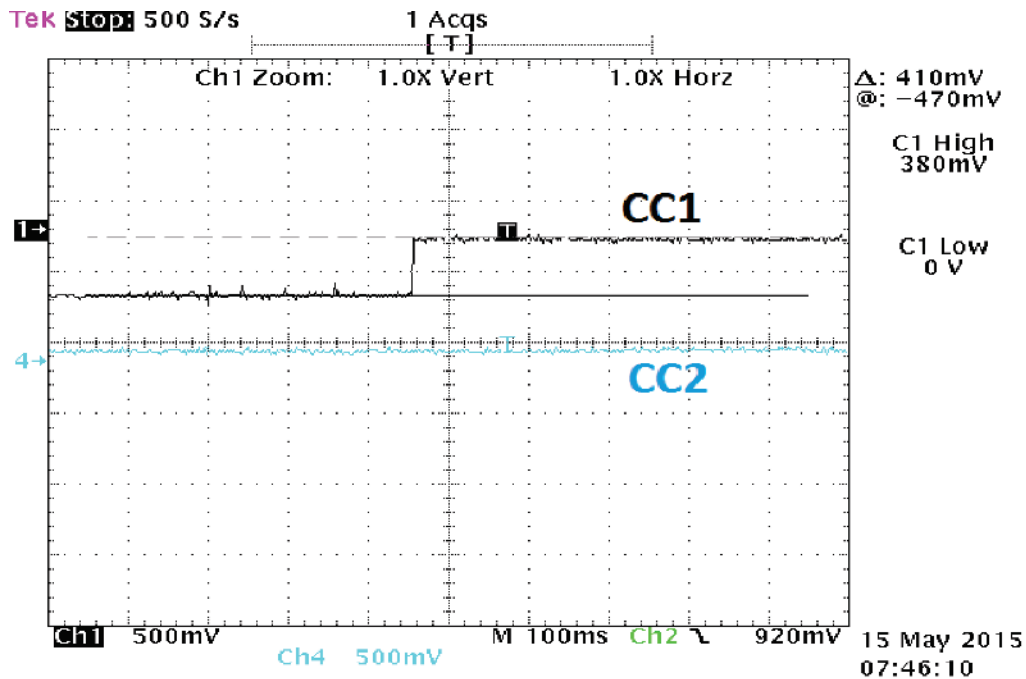

Figure 15. Application Curve for UFP in I²C Mode

9.3 Initialization Set Up

The general power-up sequence for the TUSB320 device (EN_N tied to ground) is as follows:

1. System is powered off (device has no V_{DD}). The TUSB320 device is configured internally in UFP mode with Rds on CC pins (dead battery).
2. V_{DD} ramps – POR circuit.
3. I^2C supply ramps up.
4. The TUSB320 device enters unattached mode and determines the voltage level from the PORT pin. This determines the mode in which the TUSB320 device operates (DFP, UFP, DRP).
5. The TUSB320 device monitors the CC pins as a DFP and V_{BUS} for attach as a UFP.
6. The TUSB320 device enters active mode when attach has been successfully detected.

10 Power Supply Recommendations

The TUSB320 device has a wide power supply range from 2.7 to 5 V. The TUSB320 device can be run off of a system power such as a battery.

11 Layout

11.1 Layout Guidelines

1. An extra trace (or stub) is created when connecting between more than two points. A trace connecting pin A6 to pin B6 will create a stub because the trace also has to go to the USB Host. Ensure that:
 - A stub created by short on pin A6 (DP) and pin B6 (DP) at Type-C receptacle does not exceed 3.5 mm.
 - A stub created by short on pin A7 (DM) and pin B7 (DM) at Type-C receptacle does not exceed 3.5 mm.
2. A 100-nF capacitor should be placed as close as possible to the TUSB320 V_{DD} pin.

11.2 Layout Example

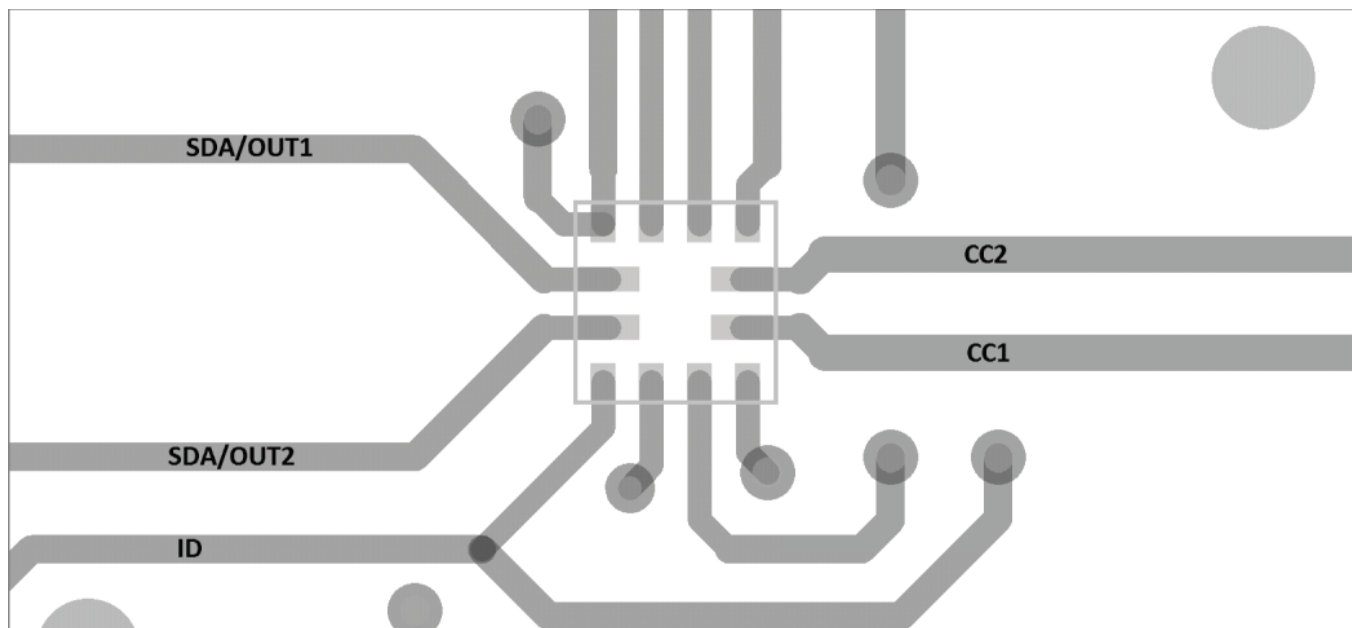

Figure 16. TUSB320 Layout

12 Device and Documentation Support

12.1 Related Links

The table below lists quick access links. Categories include technical documents, support and community resources, tools and software, and quick access to sample or buy.

Table 12. Related Links

PARTS	PRODUCT FOLDER	SAMPLE & BUY	TECHNICAL DOCUMENTS	TOOLS & SOFTWARE	SUPPORT & COMMUNITY
TUSB320	Click here	Click here	Click here	Click here	Click here
TUSB320I	Click here	Click here	Click here	Click here	Click here

12.2 Community Resources

The following links connect to TI community resources. Linked contents are provided "AS IS" by the respective contributors. They do not constitute TI specifications and do not necessarily reflect TI's views; see TI's [Terms of Use](#).

TI E2E™ Online Community *TI's Engineer-to-Engineer (E2E) Community*. Created to foster collaboration among engineers. At e2e.ti.com, you can ask questions, share knowledge, explore ideas and help solve problems with fellow engineers.

Design Support *TI's Design Support* Quickly find helpful E2E forums along with design support tools and contact information for technical support.

12.3 Trademarks

E2E is a trademark of Texas Instruments.

USB Type-C is a trademark of USB Implementers Forum.

All other trademarks are the property of their respective owners.

12.4 Electrostatic Discharge Caution



These devices have limited built-in ESD protection. The leads should be shorted together or the device placed in conductive foam during storage or handling to prevent electrostatic damage to the MOS gates.

12.5 Glossary

SLYZ022 — *TI Glossary*.

This glossary lists and explains terms, acronyms, and definitions.

13 Mechanical, Packaging, and Orderable Information

The following pages include mechanical, packaging, and orderable information. This information is the most current data available for the designated devices. This data is subject to change without notice and revision of this document. For browser-based versions of this data sheet, refer to the left-hand navigation.

PACKAGING INFORMATION

Orderable Device	Status (1)	Package Type	Package Drawing	Pins	Package Qty	Eco Plan (2)	Lead/Ball Finish (6)	MSL Peak Temp (3)	Op Temp (°C)	Device Marking (4/5)	Samples
TUSB3201RWBR	ACTIVE	X2QFN	RWB	12	3000	Green (RoHS & no Sb/Br)	CU NIPDAU	Level-2-260C-1 YEAR	-40 to 85	70	Samples
TUSB320RWBR	ACTIVE	X2QFN	RWB	12	3000	Green (RoHS & no Sb/Br)	CU NIPDAU	Level-2-260C-1 YEAR	0 to 70	20	Samples

(1) The marketing status values are defined as follows:

ACTIVE: Product device recommended for new designs.

LIFEBUY: TI has announced that the device will be discontinued, and a lifetime-buy period is in effect.

NRND: Not recommended for new designs. Device is in production to support existing customers, but TI does not recommend using this part in a new design.

PREVIEW: Device has been announced but is not in production. Samples may or may not be available.

OBSELETE: TI has discontinued the production of the device.

(2) Eco Plan - The planned eco-friendly classification: Pb-Free (RoHS), Pb-Free (RoHS Exempt), or Green (RoHS & no Sb/Br) - please check <http://www.ti.com/productcontent> for the latest availability information and additional product content details.

TBD: The Pb-Free/Green conversion plan has not been defined.

Pb-Free (RoHS): TI's terms "Lead-Free" or "Pb-Free" mean semiconductor products that are compatible with the current RoHS requirements for all 6 substances, including the requirement that lead not exceed 0.1% by weight in homogeneous materials. Where designed to be soldered at high temperatures, TI Pb-Free products are suitable for use in specified lead-free processes.

Pb-Free (RoHS Exempt): This component has a RoHS exemption for either 1) lead-based flip-chip solder bumps used between the die and package, or 2) lead-based die adhesive used between the die and leadframe. The component is otherwise considered Pb-Free (RoHS compatible) as defined above.

Green (RoHS & no Sb/Br): TI defines "Green" to mean Pb-Free (RoHS compatible), and free of Bromine (Br) and Antimony (Sb) based flame retardants (Br or Sb do not exceed 0.1% by weight in homogeneous material)

(3) MSL, Peak Temp. - The Moisture Sensitivity Level rating according to the JEDEC industry standard classifications, and peak solder temperature.

(4) There may be additional marking, which relates to the logo, the lot trace code information, or the environmental category on the device.

(5) Multiple Device Markings will be inside parentheses. Only one Device Marking contained in parentheses and separated by a "~" will appear on a device. If a line is indented then it is a continuation of the previous line and the two combined represent the entire Device Marking for that device.

(6) Lead/Ball Finish - Orderable Devices may have multiple material finish options. Finish options are separated by a vertical ruled line. Lead/Ball Finish values may wrap to two lines if the finish value exceeds the maximum column width.

Important Information and Disclaimer: The information provided on this page represents TI's knowledge and belief as of the date that it is provided. TI bases its knowledge and belief on information provided by third parties, and makes no representation or warranty as to the accuracy of such information. Efforts are underway to better integrate information from third parties. TI has taken and continues to take reasonable steps to provide representative and accurate information but may not have conducted destructive testing or chemical analysis on incoming materials and chemicals. TI and TI suppliers consider certain information to be proprietary, and thus CAS numbers and other limited information may not be available for release.

In no event shall TI's liability arising out of such information exceed the total purchase price of the TI part(s) at issue in this document sold by TI to Customer on an annual basis.

TAPE AND REEL INFORMATION

QUADRANT ASSIGNMENTS FOR PIN 1 ORIENTATION IN TAPE



*All dimensions are nominal

Device	Package Type	Package Drawing	Pins	SPQ	Reel Diameter (mm)	Reel Width W1 (mm)	A0 (mm)	B0 (mm)	K0 (mm)	P1 (mm)	W (mm)	Pin1 Quadrant
TUSB3201RWBR	X2QFN	RWB	12	3000	180.0	8.4	1.8	1.8	0.61	4.0	8.0	Q2
TUSB320RWBR	X2QFN	RWB	12	3000	180.0	8.4	1.8	1.8	0.61	4.0	8.0	Q2

TAPE AND REEL BOX DIMENSIONS

*All dimensions are nominal

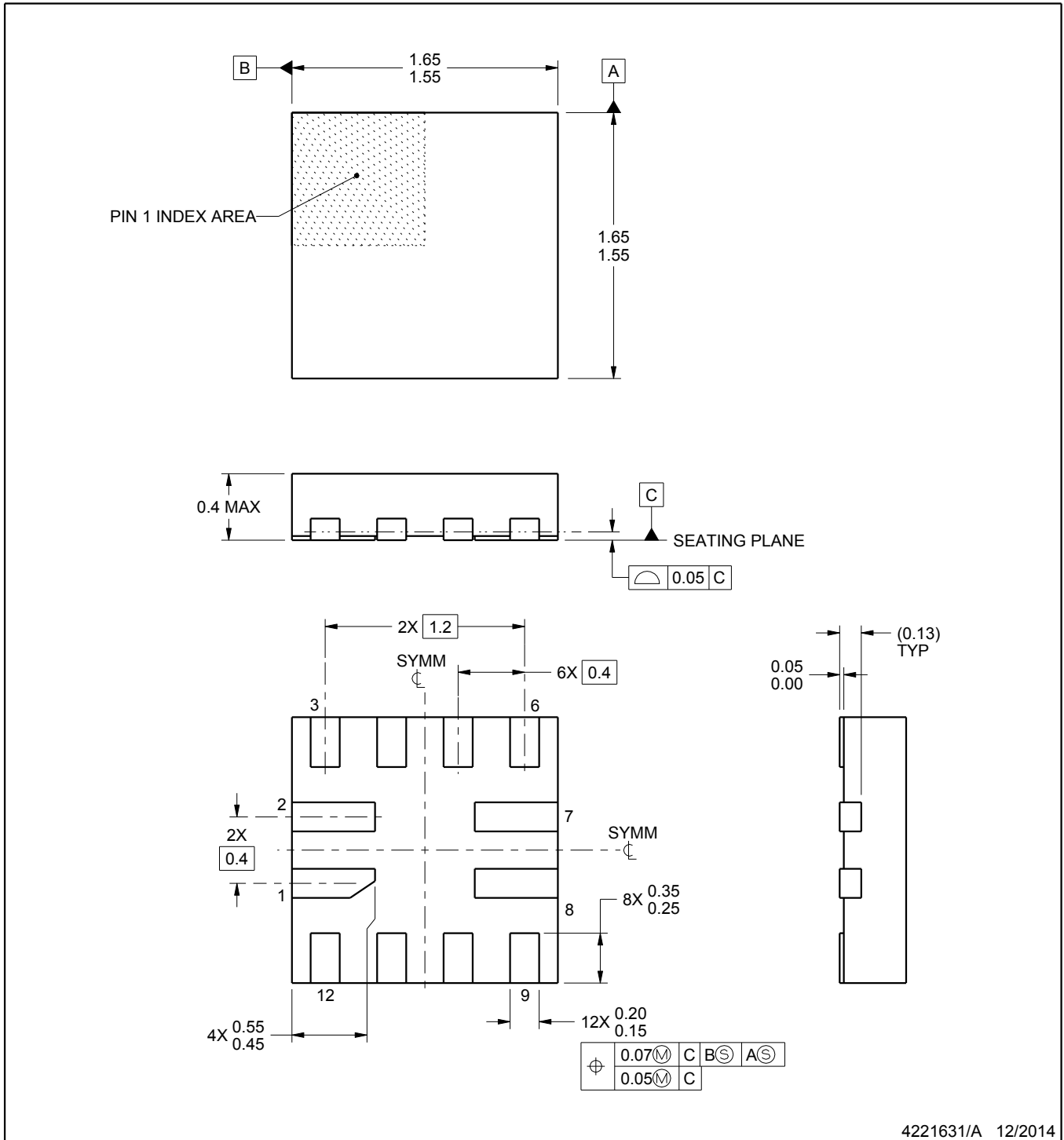
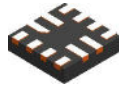
Device	Package Type	Package Drawing	Pins	SPQ	Length (mm)	Width (mm)	Height (mm)
TUSB320IRWBR	X2QFN	RWB	12	3000	195.0	200.0	45.0
TUSB320RWBR	X2QFN	RWB	12	3000	195.0	200.0	45.0



4221631/A 12/2014

NOTES:

1. All linear dimensions are in millimeters. Any dimensions in parenthesis are for reference only. Dimensioning and tolerancing per ASME Y14.5M.
2. This drawing is subject to change without notice.

EXAMPLE BOARD LAYOUT

RWB0012A

X2QFN - 0.4 mm max height

PLASTIC QUAD FLATPACK - NO LEAD

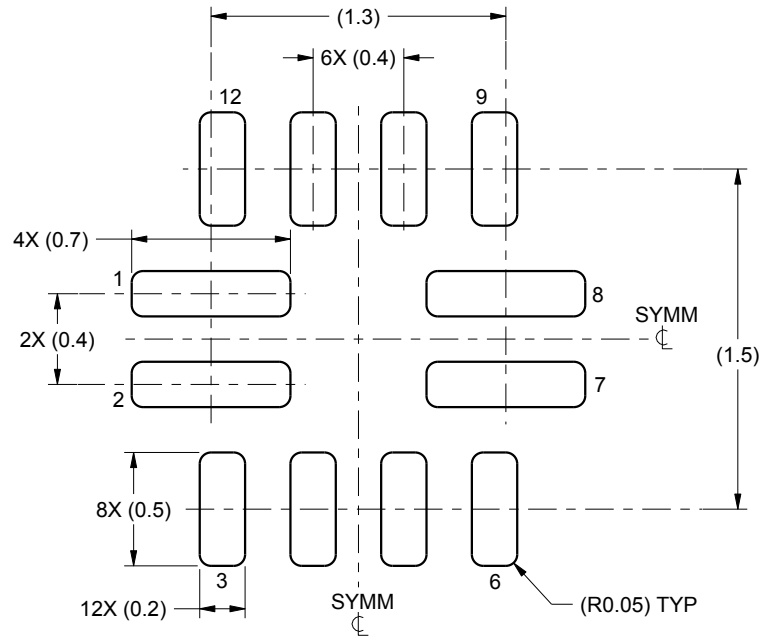

LAND PATTERN EXAMPLE
SCALE:30X

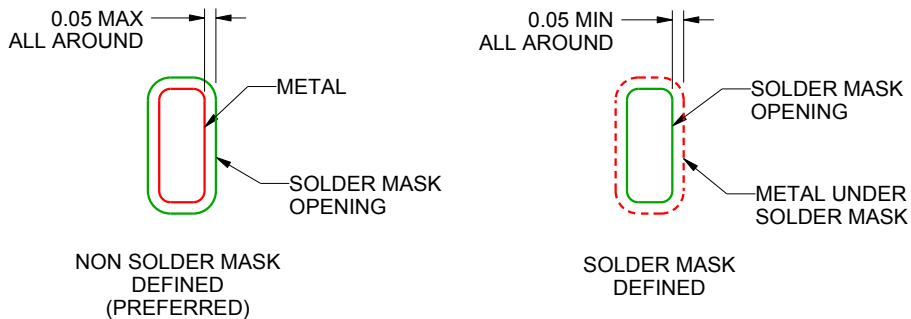

SOLDER MASK DETAILS

4221631/A 12/2014

NOTES: (continued)

3. For more information, see Texas Instruments literature number SLUA271 (www.ti.com/lit/slua271).

EXAMPLE STENCIL DESIGN

RWB0012A

X2QFN - 0.4 mm max height

PLASTIC QUAD FLATPACK - NO LEAD

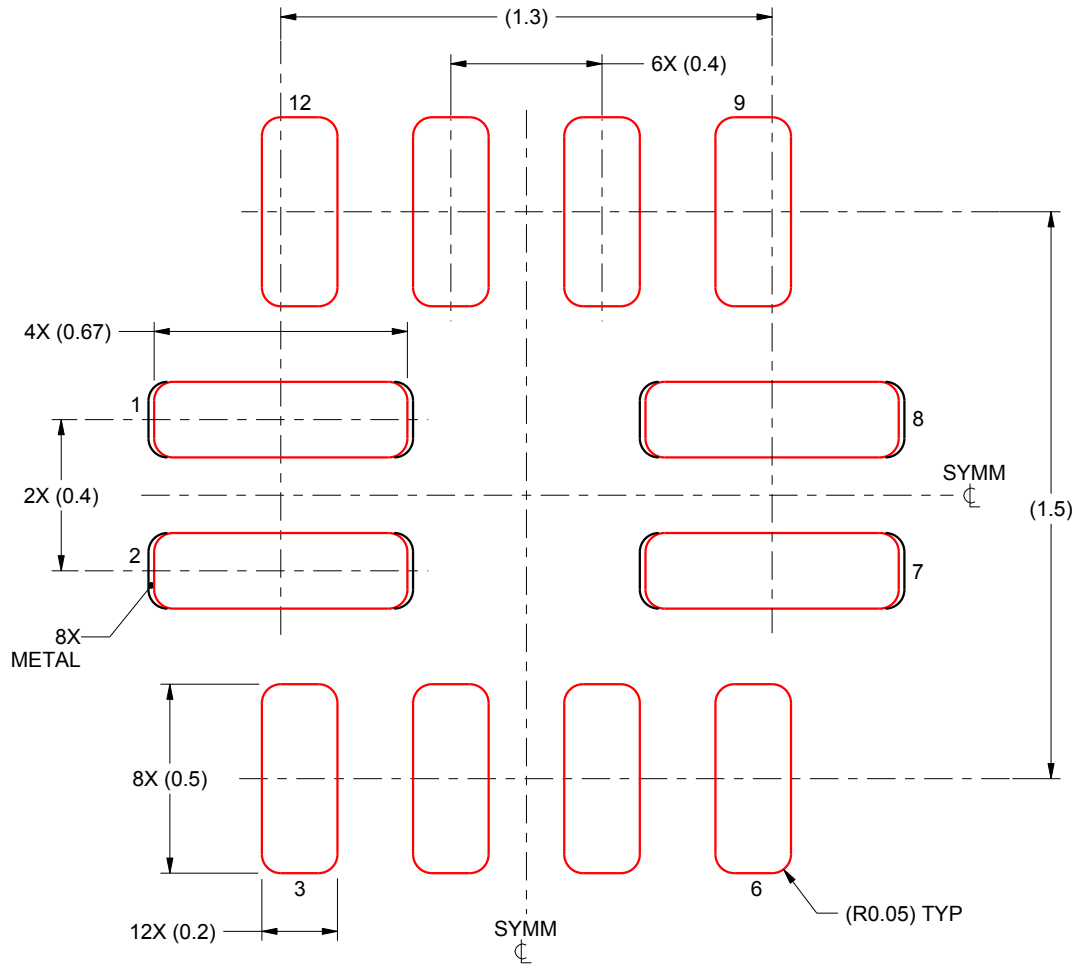

SOLDER PASTE EXAMPLE
BASED ON 0.1 mm THICK STENCIL
PADS 1,2,7 & 8
96% PRINTED SOLDER COVERAGE BY AREA
SCALE:50X

4221631/A 12/2014

NOTES: (continued)

4. Laser cutting apertures with trapezoidal walls and rounded corners may offer better paste release. IPC-7525 may have alternate design recommendations.

IMPORTANT NOTICE

Texas Instruments Incorporated and its subsidiaries (TI) reserve the right to make corrections, enhancements, improvements and other changes to its semiconductor products and services per JESD46, latest issue, and to discontinue any product or service per JESD48, latest issue. Buyers should obtain the latest relevant information before placing orders and should verify that such information is current and complete. All semiconductor products (also referred to herein as "components") are sold subject to TI's terms and conditions of sale supplied at the time of order acknowledgment.

TI warrants performance of its components to the specifications applicable at the time of sale, in accordance with the warranty in TI's terms and conditions of sale of semiconductor products. Testing and other quality control techniques are used to the extent TI deems necessary to support this warranty. Except where mandated by applicable law, testing of all parameters of each component is not necessarily performed.

TI assumes no liability for applications assistance or the design of Buyers' products. Buyers are responsible for their products and applications using TI components. To minimize the risks associated with Buyers' products and applications, Buyers should provide adequate design and operating safeguards.

TI does not warrant or represent that any license, either express or implied, is granted under any patent right, copyright, mask work right, or other intellectual property right relating to any combination, machine, or process in which TI components or services are used. Information published by TI regarding third-party products or services does not constitute a license to use such products or services or a warranty or endorsement thereof. Use of such information may require a license from a third party under the patents or other intellectual property of the third party, or a license from TI under the patents or other intellectual property of TI.

Reproduction of significant portions of TI information in TI data books or data sheets is permissible only if reproduction is without alteration and is accompanied by all associated warranties, conditions, limitations, and notices. TI is not responsible or liable for such altered documentation. Information of third parties may be subject to additional restrictions.

Resale of TI components or services with statements different from or beyond the parameters stated by TI for that component or service voids all express and any implied warranties for the associated TI component or service and is an unfair and deceptive business practice. TI is not responsible or liable for any such statements.

Buyer acknowledges and agrees that it is solely responsible for compliance with all legal, regulatory and safety-related requirements concerning its products, and any use of TI components in its applications, notwithstanding any applications-related information or support that may be provided by TI. Buyer represents and agrees that it has all the necessary expertise to create and implement safeguards which anticipate dangerous consequences of failures, monitor failures and their consequences, lessen the likelihood of failures that might cause harm and take appropriate remedial actions. Buyer will fully indemnify TI and its representatives against any damages arising out of the use of any TI components in safety-critical applications.

In some cases, TI components may be promoted specifically to facilitate safety-related applications. With such components, TI's goal is to help enable customers to design and create their own end-product solutions that meet applicable functional safety standards and requirements. Nonetheless, such components are subject to these terms.

No TI components are authorized for use in FDA Class III (or similar life-critical medical equipment) unless authorized officers of the parties have executed a special agreement specifically governing such use.

Only those TI components which TI has specifically designated as military grade or "enhanced plastic" are designed and intended for use in military/aerospace applications or environments. Buyer acknowledges and agrees that any military or aerospace use of TI components which have **not** been so designated is solely at the Buyer's risk, and that Buyer is solely responsible for compliance with all legal and regulatory requirements in connection with such use.

TI has specifically designated certain components as meeting ISO/TS16949 requirements, mainly for automotive use. In any case of use of non-designated products, TI will not be responsible for any failure to meet ISO/TS16949.

Products

Audio	www.ti.com/audio
Amplifiers	amplifier.ti.com
Data Converters	dataconverter.ti.com
DLP® Products	www.dlp.com
DSP	dsp.ti.com
Clocks and Timers	www.ti.com/clocks
Interface	interface.ti.com
Logic	logic.ti.com
Power Mgmt	power.ti.com
Microcontrollers	microcontroller.ti.com
RFID	www.ti-rfid.com
OMAP Applications Processors	www.ti.com/omap
Wireless Connectivity	www.ti.com/wirelessconnectivity

Applications

Automotive and Transportation	www.ti.com/automotive
Communications and Telecom	www.ti.com/communications
Computers and Peripherals	www.ti.com/computers
Consumer Electronics	www.ti.com/consumer-apps
Energy and Lighting	www.ti.com/energy
Industrial	www.ti.com/industrial
Medical	www.ti.com/medical
Security	www.ti.com/security
Space, Avionics and Defense	www.ti.com/space-avionics-defense
Video and Imaging	www.ti.com/video

TI E2E Community

e2e.ti.com