

# 128 TAPS Single Channel Digital Potentiometer with I<sup>2</sup>C Interface

Check for Samples: [TPL0401A](#), [TPL0401B](#), [TPL0401C](#)

## FEATURES

- Single Channel, 128-Position Resolution
- 10 kΩ End-to-End Resistance Options
- Low Temperature Coefficient: 35 ppm/°C
- I<sup>2</sup>C Serial Interface
- 2.7 V to 5.5 V Single-Supply Operation
- ±20% Resistance Tolerance
- 'A' and 'B' Versions Have Different I<sup>2</sup>C Addresses
- 'L' Terminal of 'A' and 'B' version is internal and connected To GND
- 'H' Terminal of 'C' Version is Internal and Floating
- Operating Temperature –40°C to 125°C
- Available in Industry Standard SC70 Packages
- ESD Performance Tested per JESD 22
  - 2000 V Human Body Model (A114-B, Class II)

## APPLICATIONS

- Low Power DDR3 Voltage Reference
- Adjustable Power Supplies
- Adjustable Gain Amplifiers and Offset Trimming
- Precision Calibration of Set Point Thresholds
- Sensor Trimming and Calibration
- Mechanical Potentiometer Replacement

## DESCRIPTION

The TPL0401 is a single channel, linear-taper digital potentiometer with 128 wiper positions. The TPL0401A/B have the low terminal internal and connected to GND. The position of the wiper can be adjusted using an I<sup>2</sup>C interface. The TPL0401 is available in a 6-pin SC-70 package with a specified temperature range of –40°C to 125°C. The part has a 10k end-to-end resistance and can operate with a supply voltage range of 2.7V to 5.5V. This kind of product is widely used in setting the voltage reference for low power DDR3 memory.

The TPL0401A/B have the Low Terminal internal and connected to GND. The TPL0401C has the High Terminal internal and floating.

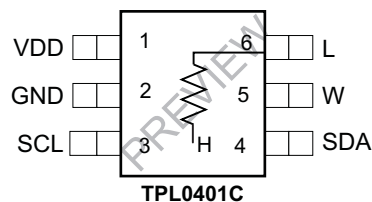
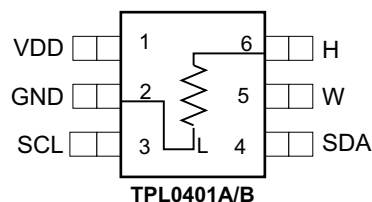
SC-70 DCK PACKAGE  
(TOP VIEW)

## ORDERING INFORMATION

T <sub>A</sub>	PACKAGE <sup>(1)</sup>		ORDERABLE PART NUMBER	END-TO-END RESISTANCE	I <sup>2</sup> C ADDRESS	TOP-SIDE MARKING
–40°C to 125°C	SC70 – DCK	Tape and Reel	TPL0401A-10DCKR	10-kΩ	0101110	7TV
			TPL0401B-10DCKR	10-kΩ	0111110	7UV
			TPL0401C-50DCKR	50-kΩ	0101110	TBD

(1) Package drawings, standard packing quantities, thermal data, symbolization, and PCB design guidelines are available at [www.ti.com/sc/package](http://www.ti.com/sc/package).



Please be aware that an important notice concerning availability, standard warranty, and use in critical applications of Texas Instruments semiconductor products and disclaimers thereto appears at the end of this data sheet.



These devices have limited built-in ESD protection. The leads should be shorted together or the device placed in conductive foam during storage or handling to prevent electrostatic damage to the MOS gates.

### PIN FUNCTIONS

PIN NUMBER	PIN NAME	TYPE	DESCRIPTION
1	VDD	Power	Positive Supply Voltage
2	GND	Ground	Ground
3	SCL	Input	I2C Clock
4	SDA	I/O	I2C Data
5	W	I/O	Wiper terminal
6	H	I/O	High terminal
–	L	I/O	Low terminal

### FUNCTIONAL BLOCK DIAGRAM

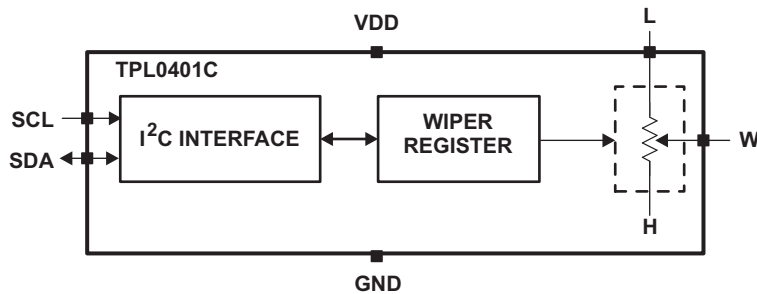
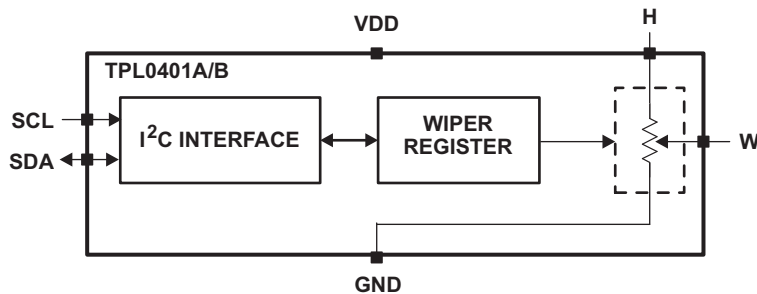

## DIGITAL POTENTIOMETER CONFIGURATIONS

### VOLTAGE DIVIDER MODE

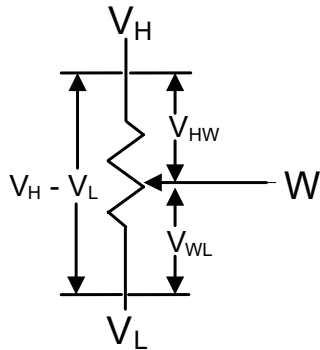

$$V_{HW} = (V_H - V_L) \times (1 - (D/128))$$

$$V_{WL} = (V_H - V_L) \times D/128$$

Where D = Decimal Value of Wiper Code

### RHEOSTAT MODE A

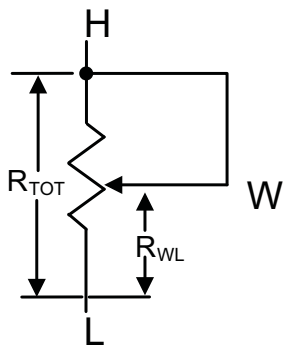

OR

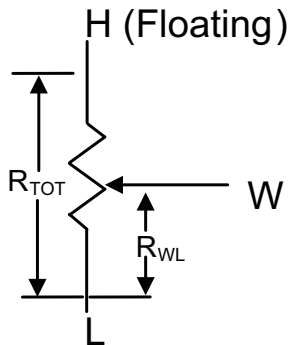

$$R_{WL} = R_{TOT} \times D/128$$

Where D = Decimal Value of Wiper Code

### RHEOSTAT MODE B

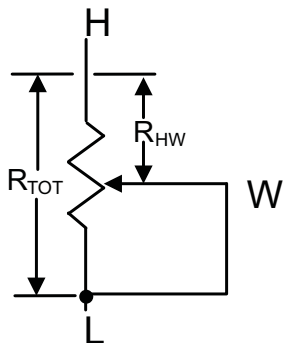

OR

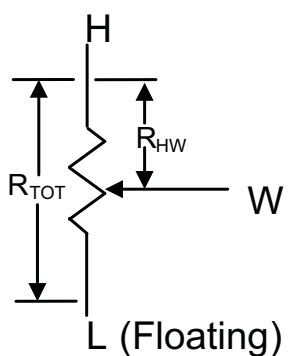

$$R_{HW} = R_{TOT} \times (1 - (D/128))$$

Where D = Decimal Value of Wiper Code

Figure 1. DPOT Configurations

### ABSOLUTE MAXIMUM RATINGS<sup>(1)(2)(3)</sup>

over operating free-air temperature range (unless otherwise noted)

		MIN	MAX	UNIT	
V <sub>DD</sub> to GND	Supply voltage range	-0.3	7	V	
All other pins to GND		-0.3	V <sub>DD</sub> +0.3	V	
I <sub>H</sub>	Pulse current		±20	mA	
I <sub>L</sub>	Continuous current	TPL0401A/B-10		±5	mA
I <sub>W</sub>		TPL0401C-50		±1.3	mA
V <sub>I</sub>	Digital input voltage range	-0.3	V <sub>DD</sub> + 0.3	V	
θ <sub>JA</sub>	Package thermal impedance <sup>(4)</sup>	DCK package		259	°C/W
T <sub>stg</sub>	Storage temperature range	-65	150	°C	

- (1) Stresses above these ratings may cause permanent damage. Exposure to absolute maximum conditions for extended periods may degrade device reliability. These are stress ratings only, and functional operation of the device at these or any other conditions beyond those specified is not implied.
- (2) The algebraic convention, whereby the most negative value is a minimum and the most positive value is a maximum
- (3) All voltages are with respect to ground, unless otherwise specified.
- (4) The package thermal impedance is calculated in accordance with JESD 51-7.

### RECOMMENDED OPERATING CONDITIONS

	DESCRIPTION	MIN	MAX	Unit
V <sub>DD</sub>	Supply Voltage	2.7	5.5	V
V <sub>W</sub> , V <sub>H</sub>	Terminal Voltage	0	V <sub>DD</sub>	V
V <sub>IH</sub>	Voltage Input High ( SCLK, SDA )	0.7 V <sub>DD</sub>		V
V <sub>IL</sub>	Voltage Input Low ( SCLK, SDA)		0.3 V <sub>DD</sub>	V
I <sub>W</sub>	Wiper Current		±2	mA
T <sub>A</sub>	Ambient Operating temperature	-40	128	°C

## ANALOG SPECIFICATIONS

Typical values are specified at 25°C and V<sub>DD</sub>=3.3V

PARAMETER		CONDITIONS	MIN	TYP	MAX	UNIT
R <sub>TOTAL</sub>	End-to-end resistance (between H and L terminals)	TPL0401A/B-10	8	10	12	kΩ
		TPL0401C-50	40	50	60	kΩ
V <sub>H</sub>	Terminal voltage range		0		V <sub>DD</sub>	V
R <sub>H</sub>	Terminal resistance			35	100	Ω
R <sub>W</sub>	Wiper resistance			35	100	Ω
C <sub>H</sub>	Terminal capacitance			10		pF
C <sub>W</sub>	Wiper capacitance			11		pF
I <sub>LKG</sub>	Terminal leakage current			0.1	1	μA
T <sub>CR</sub>	Resistance temperature coefficient	TPL0401A/B-10		22		ppm/°C
		TPL0401C-50		TBD		ppm/°C
<b>VOLTAGE DIVIDER MODE (TPL0401A, TPL0401B, V<sub>H</sub> = V<sub>DD</sub>, V<sub>W</sub> = Not Loaded)</b>						
INL	Integral non-linearity		-0.5		0.5	LSB
DNL	Differential non-linearity		-0.25		0.25	LSB
Z <sub>ERROR</sub>	Zero-scale error		0	0.75	1.5	LSB
F <sub>ERROR</sub>	Full-scale error		-1.5	-0.75	0	LSB
T <sub>CV</sub>	Ratiometric temperature coefficient	Wiper set at mid-scale		4		ppm/°C
BW	Bandwidth	Wiper set at mid-scale, , C <sub>LOAD</sub> = 10 pF		2862		kHz
T <sub>SW</sub>	Wiper settling time			0.152		μs
THD	Total harmonic distortion	V <sub>H</sub> = 1 V <sub>RMS</sub> at 1 kHz, V <sub>L</sub> = V <sub>DD</sub> /2, Measurement at W			0.03	%
<b>RHEOSTAT MODE (TPL0401C)</b>						
RINL	Integral non-linearity				TBD	LSB
RDNL	Differential non-linearity				TBD	LSB
R <sub>OFFSET</sub>	Offset				TBD	LSB
RBW	Bandwidth	Code=0x00h, L Floating, Input applied to W, 10pF on H			TBD	kHz

## OPERATING SPECIFICATIONS

Typical values are specified at 25°C and V<sub>DD</sub>=3.3V<sup>(1)</sup>

PARAMETER		CONDITIONS	MIN	TYP	MAX	UNIT
I <sub>DD(STBY)</sub>	V <sub>DD</sub> Standby current	-40 to 85°C			0.5	μA
		-40 to 125°C			1.5	μA
I <sub>IN-DIG</sub>	Digital Pins Leakage Current (SCL, SDA Inputs)		-1		1	μA
<b>SERIAL INTERFACE SPECS (SDA, SCL)</b>						
V <sub>IH</sub>	Input high voltage		0.7 × V <sub>DD</sub>		5.5	V
V <sub>IL</sub>	Input low voltage		0	0.3 × V <sub>DD</sub>		V
V <sub>OL</sub>	Output low voltage	SDA Pin, I <sub>OL</sub> = 4 mA			0.4	V
C <sub>IN</sub>	Pin capacitance	SCL, SDA Inputs		7		pF
<b>I<sup>2</sup>C INTERFACE TIMING REQUIREMENTS</b>						
		STANDARD MODE I <sup>2</sup> C BUS		FAST MODE I <sup>2</sup> C BUS		UNITS
		MIN	MAX	MIN	MAX	
f <sub>SCL</sub>	I <sup>2</sup> C Clock frequency	0	100	0	400	kHz
t <sub>SCH</sub>	I <sup>2</sup> C Clock high time	4		0.6		μs
t <sub>SCL</sub>	I <sup>2</sup> C Clock low time	4.7		1.3		μs
t <sub>sp</sub>	I <sup>2</sup> C Spike time	0	50	0	50	ns
t <sub>SDS</sub>	I <sup>2</sup> C Serial data setup time	250		100		ns
t <sub>SDH</sub>	I <sup>2</sup> C Serial data hold time	0		0		ns
t <sub>ICR</sub>	I <sup>2</sup> C Input rise time		1000	20 + 0.1C <sub>b</sub>	300	ns
t <sub>ICF</sub>	I <sup>2</sup> C Input fall time		300	20 + 0.1C <sub>b</sub>	300	ns
t <sub>ICF</sub>	I <sup>2</sup> C Output fall time, 10 pF to 400 pF bus		300	20 + 0.1C <sub>b</sub>	300	ns
t <sub>BUF</sub>	I <sup>2</sup> C Bus free time between stop and start	4.7		1.3		μs
t <sub>STS</sub>	I <sup>2</sup> C Start or repeater start condition setup time	4.7		1.3		μs
t <sub>STH</sub>	I <sup>2</sup> C Start or repeater start condition hold time	4		0.6		μs
t <sub>SPS</sub>	I <sup>2</sup> C Stop condition setup time	4		0.6		μs
t <sub>VD(DATA)</sub>	Valid data time, SCL low to SDA output valid		1		1	μs
t <sub>VD(DATA)</sub>	Valid data time of ACK condition, ACK signal from SCL low to SDA (out) low		1		1	μs

(1) Parameters with Min and Max limits are 100% tested at +25C, unless otherwise specified. Temperature limits established by characterization and are not production tested

TYPICAL CHARACTERISTICS

INL vs TAP POSITION (Potentiometer Mode)

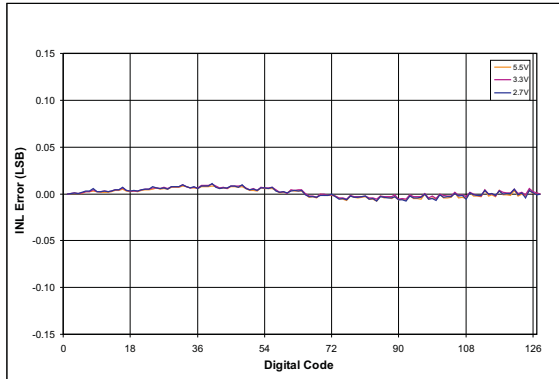

Figure 2.

DNL vs TAP POSITION (Potentiometer Mode)

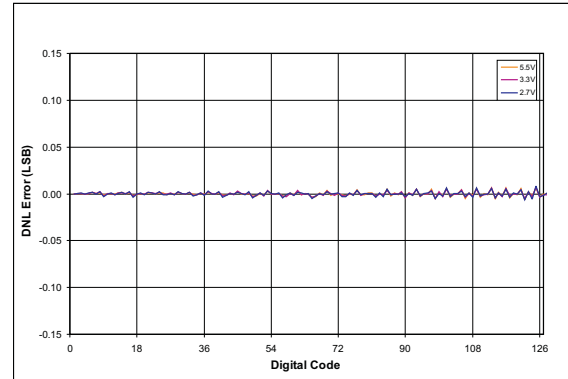

Figure 3.

INL vs TAP POSITION (Rheostat Mode)

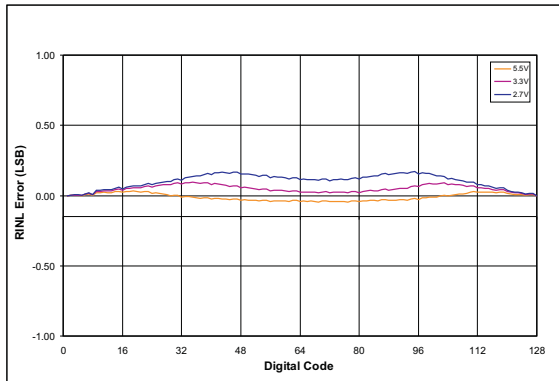

Figure 4.

DNL vs TAP POSITION (Rheostat Mode)

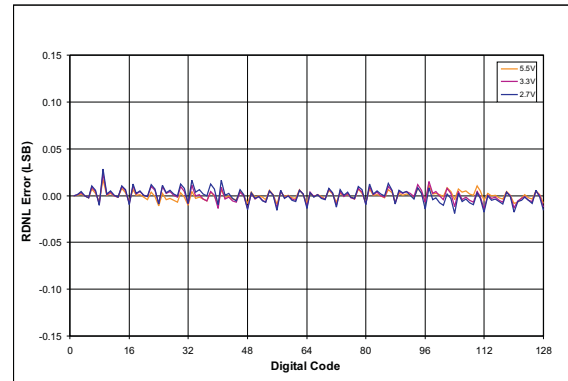

Figure 5.

ZERO SCALE ERROR vs TEMPERATURE

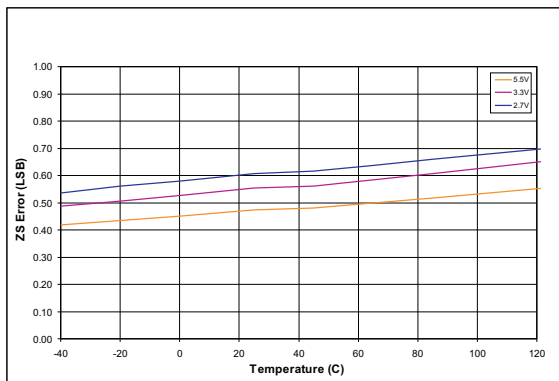

Figure 6.

FULL SCALE ERROR vs TEMPERATURE

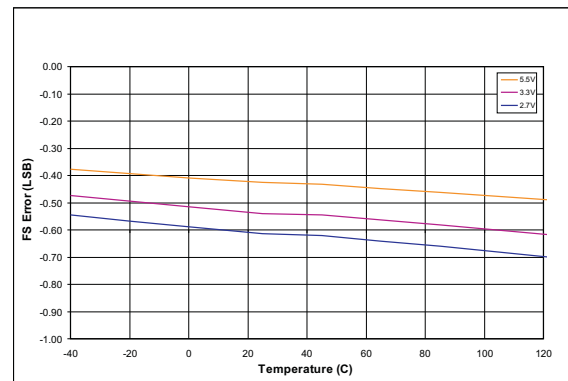

Figure 7.

**TYPICAL CHARACTERISTICS (continued)**

**END-TO-END RTOTAL% CHANGE vs TEMPERATURE**

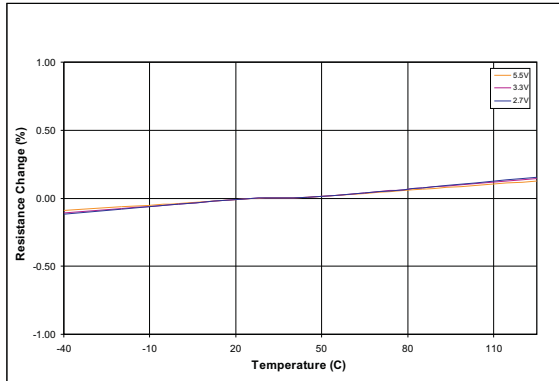

Figure 8.

**TEMPERATURE COEFFICIENT vs TAP POSITION (Potentiometer Mode)**

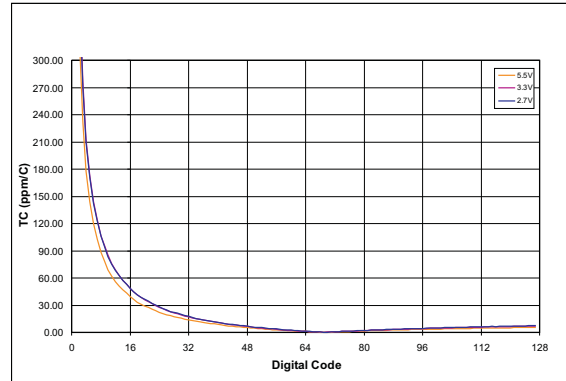

Figure 9.

**TEMPERATURE COEFFICIENT vs TAP POSITION (Rheostat Mode)**

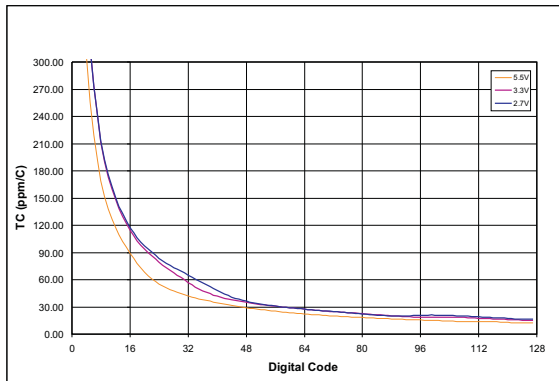

Figure 10.

**FREQUENCY RESPONSE**

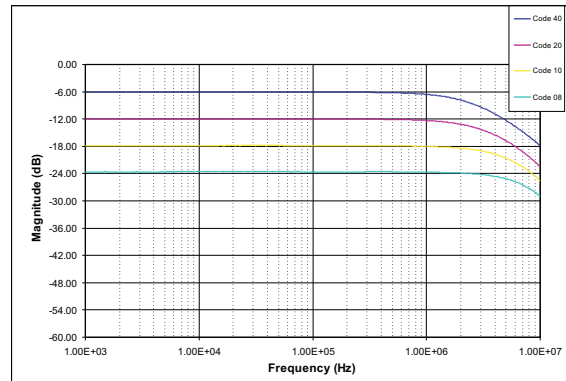

Figure 11.



## SLAVE ADDRESS

### TPL0401A, TPL0401C

BIT 7 (MSB)	BIT 6	BIT 5	BIT 4	BIT 3	BIT 2	BIT 1	BIT 0 (LSB)
0	1	0	1	1	1	0	R/W

### TPL0401B

BIT 7 (MSB)	BIT 6	BIT 5	BIT 4	BIT 3	BIT 2	BIT 1	BIT 0 (LSB)
0	1	1	1	1	1	0	R/W

## WRITE AND READ PROTOCOL

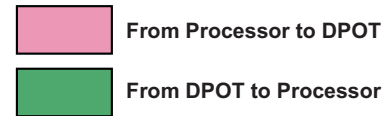

### I<sup>2</sup>C Write to A Register

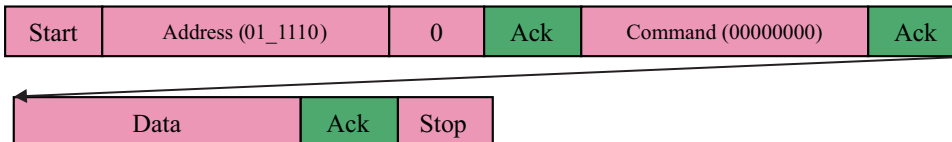

### I<sup>2</sup>C Read From A Register

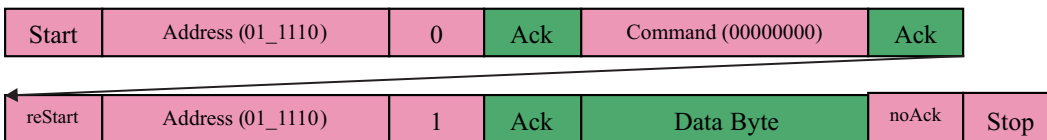

## Standard I<sup>2</sup>C Interface Details

The bidirectional I<sup>2</sup>C bus consists of the serial clock (SCL) and serial data (SDA) lines. Both lines must be connected to a positive supply via a pullup resistor when connected to the output stages of a device. Data transfer may be initiated only when the bus is not busy.

I<sup>2</sup>C communication with this device is initiated by the master sending a start condition, a high-to-low transition on the SDA input/output while the SCL input is high (see Figure 13). After the start condition, the device address byte is sent, MSB first, including the data direction bit (R/W). This device does not respond to the general call address. After receiving the valid address byte, this device responds with an ACK, a low on the SDA input/output during the high of the ACK-related clock pulse.

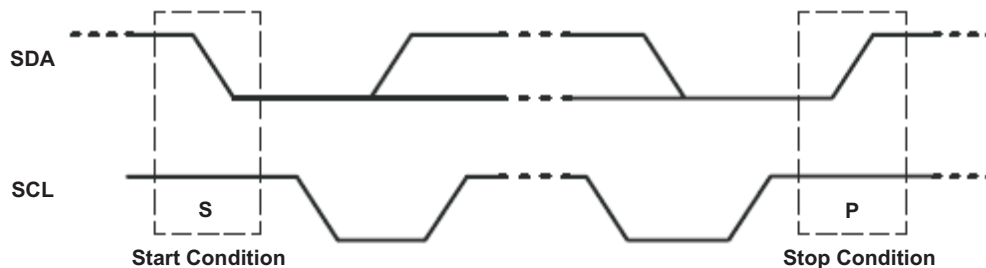

Figure 12. Definition of Start and Stop Conditions

The data byte follows the address ACK. The R/W bit is kept low for transfer from the master to the slave. The data byte is followed by an ACK sent from this device. Data are output only if complete bytes are received and acknowledged. The output data is valid at time (tpv) after the low-to-high transition of SCL, during the clock cycle for the ACK.

On the I<sup>2</sup>C bus, only one data bit is transferred during each clock pulse. The data on the SDA line must remain stable during the high pulse of the clock period, as changes in the data line at this time are interpreted as control commands (start or stop) (see Figure 13).

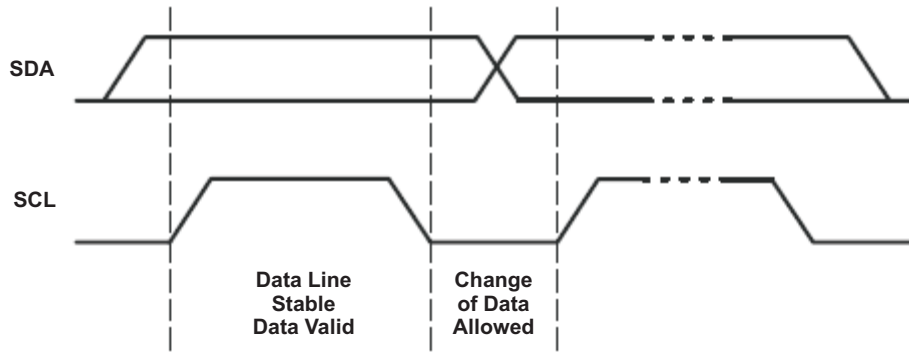

Figure 13. Bit Transfer

A stop condition, a low-to-high transition on the SDA input/output while the SCL input is high, is sent by the master (see Figure 13).

The number of data bytes transferred between the start and the stop conditions from transmitter to receiver is not limited. Each byte of eight bits is followed by one ACK bit. The transmitter must release the SDA line before the receiver can send an ACK bit.

A slave receiver that is addressed must generate an ACK after the reception of each byte. The device that acknowledges has to pull down the SDA line during the ACK clock pulse so that the SDA line is stable low during the high pulse of the ACK-related clock period (see Figure 14). Setup and hold times must be taken into account.

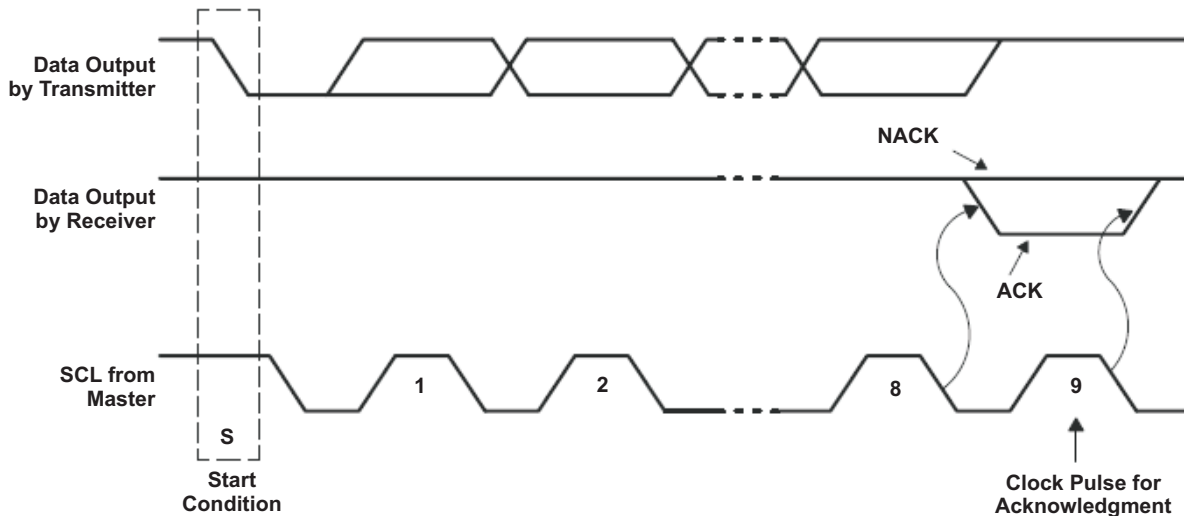

Figure 14. Acknowledgement on the I<sup>2</sup>C Bus

TYPICAL APPLICATION

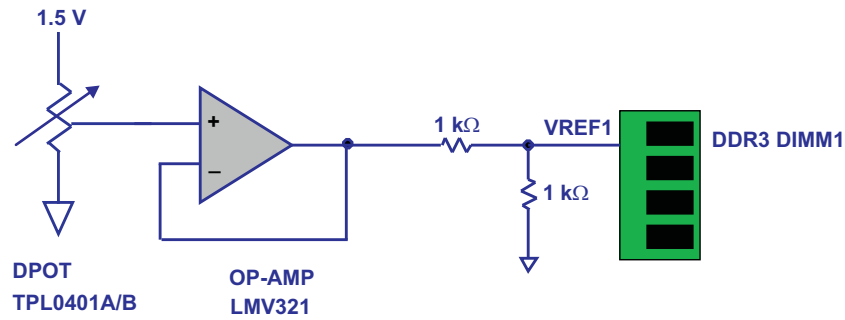

Figure 15. DDR3 Voltage Reference Adjustment

Below table shows Ideal values of resistance for a 10kΩ DPOT. The absolute values can vary significantly, but the ratio (Rhw/Rwl) is extremely accurate.

Table 1. Resistance Values Table

Step	Binary	Rwl (kΩ)	Rhw (kΩ)	Rhw/Rwl
0	0	0.00	10.00	0.00
1	1	0.08	9.92	0.01
2	10	0.16	9.84	0.02
3	11	0.23	9.77	0.02
4	100	0.31	9.69	0.03
5	101	0.39	9.61	0.04
6	110	0.47	9.53	0.05
7	111	0.55	9.45	0.06
8	1000	0.63	9.38	0.07
9	1001	0.70	9.30	0.08
10	1010	0.78	9.22	0.08
11	1011	0.86	9.14	0.09
12	1100	0.94	9.06	0.10
13	1101	1.02	8.98	0.11
14	1110	1.09	8.91	0.12
15	1111	1.17	8.83	0.13
16	10000	1.25	8.75	0.14
17	10001	1.33	8.67	0.15
18	10010	1.41	8.59	0.16
19	10011	1.48	8.52	0.17
20	10100	1.56	8.44	0.19
21	10101	1.64	8.36	0.20
22	10110	1.72	8.28	0.21
23	10111	1.80	8.20	0.22
24	11000	1.88	8.13	0.23
25	11001	1.95	8.05	0.24
26	11010	2.03	7.97	0.25
27	11011	2.11	7.89	0.27
28	11100	2.19	7.81	0.28
29	11101	2.27	7.73	0.29
30	11110	2.34	7.66	0.31
31	11111	2.42	7.58	0.32

**Table 1. Resistance Values Table (continued)**

Step	Binary	Rwl (kΩ)	Rhw (kΩ)	Rhw/Rwl
32	100000	2.50	7.50	0.33
33	100001	2.58	7.42	0.35
34	100010	2.66	7.34	0.36
35	100011	2.73	7.27	0.38
36	100100	2.81	7.19	0.39
37	100101	2.89	7.11	0.41
38	100110	2.97	7.03	0.42
39	100111	3.05	6.95	0.44
40	101000	3.13	6.88	0.45
41	101001	3.20	6.80	0.47
42	101010	3.28	6.72	0.49
43	101011	3.36	6.64	0.51
44	101100	3.44	6.56	0.52
45	101101	3.52	6.48	0.54
46	101110	3.59	6.41	0.56
47	101111	3.67	6.33	0.58
48	110000	3.75	6.25	0.60
49	110001	3.83	6.17	0.62
50	110010	3.91	6.09	0.64
51	110011	3.98	6.02	0.66
52	110100	4.06	5.94	0.68
53	110101	4.14	5.86	0.71
54	110110	4.22	5.78	0.73
55	110111	4.30	5.70	0.75
56	111000	4.38	5.63	0.78
57	111001	4.45	5.55	0.80
58	111010	4.53	5.47	0.83
59	111011	4.61	5.39	0.86
60	111100	4.69	5.31	0.88
61	111101	4.77	5.23	0.91
62	111110	4.84	5.16	0.94
63	111111	4.92	5.08	0.97
64	1000000	5.00	5.00	1.00
65	1000001	5.08	4.92	1.03
66	1000010	5.16	4.84	1.06
67	1000011	5.23	4.77	1.10
68	1000100	5.31	4.69	1.13
69	1000101	5.39	4.61	1.17
70	1000110	5.47	4.53	1.21
71	1000111	5.55	4.45	1.25
72	1001000	5.63	4.38	1.29
73	1001001	5.70	4.30	1.33
74	1001010	5.78	4.22	1.37
75	1001011	5.86	4.14	1.42
76	1001100	5.94	4.06	1.46
77	1001101	6.02	3.98	1.51
78	1001110	6.09	3.91	1.56

**Table 1. Resistance Values Table (continued)**

Step	Binary	Rwl (kΩ)	Rhw (kΩ)	Rhw/Rwl
79	1001111	6.17	3.83	1.61
80	1010000	6.25	3.75	1.67
81	1010001	6.33	3.67	1.72
82	1010010	6.41	3.59	1.78
83	1010011	6.48	3.52	1.84
84	1010100	6.56	3.44	1.91
85	1010101	6.64	3.36	1.98
86	1010110	6.72	3.28	2.05
87	1010111	6.80	3.20	2.12
88	1011000	6.88	3.13	2.20
89	1011001	6.95	3.05	2.28
90	1011010	7.03	2.97	2.37
91	1011011	7.11	2.89	2.46
92	1011100	7.19	2.81	2.56
93	1011101	7.27	2.73	2.66
94	1011110	7.34	2.66	2.76
95	1011111	7.42	2.58	2.88
96	1100000	7.50	2.50	3.00
97	1100001	7.58	2.42	3.13
98	1100010	7.66	2.34	3.27
99	1100011	7.73	2.27	3.41
100	1100100	7.81	2.19	3.57
101	1100101	7.89	2.11	3.74
102	1100110	7.97	2.03	3.92
103	1100111	8.05	1.95	4.12
104	1101000	8.13	1.88	4.33
105	1101001	8.20	1.80	4.57
106	1101010	8.28	1.72	4.82
107	1101011	8.36	1.64	5.10
108	1101100	8.44	1.56	5.40
109	1101101	8.52	1.48	5.74
110	1101110	8.59	1.41	6.11
111	1101111	8.67	1.33	6.53
112	1110000	8.75	1.25	7.00
113	1110001	8.83	1.17	7.53
114	1110010	8.91	1.09	8.14
115	1110011	8.98	1.02	8.85
116	1110100	9.06	0.94	9.67
117	1110101	9.14	0.86	10.64
118	1110110	9.22	0.78	11.80
119	1110111	9.30	0.70	13.22
120	1111000	9.38	0.63	15.00
121	1111001	9.45	0.55	17.29
122	1111010	9.53	0.47	20.33
123	1111011	9.61	0.39	24.60
124	1111100	9.69	0.31	31.00
125	1111101	9.77	0.23	41.67

**Table 1. Resistance Values Table (continued)**

Step	Binary	Rwl (k $\Omega$ )	Rhw (k $\Omega$ )	Rhw/Rwl
126	1111110	9.84	0.16	63.00
127	1111111	9.92	0.08	127.00

---

**Changes from Original (September 2011) to Revision A****Page**

• Added TPL0401C device to the Datasheet. ....	1
• Added TPL0401C Package. ....	1
• Added TPL0401C Functional Block Diagram. ....	2

---

## PACKAGING INFORMATION

Orderable Device	Status (1)	Package Type	Package Drawing	Pins	Package Qty	Eco Plan (2)	Lead/Ball Finish (6)	MSL Peak Temp (3)	Op Temp (°C)	Device Marking (4/5)	Samples
TPL0401A-10DCKR	ACTIVE	SC70	DCK	6	3000	Green (RoHS & no Sb/Br)	CU NIPDAU	Level-1-260C-UNLIM	-40 to 125	(7TD ~ 7TV)	<a href="#">Samples</a>
TPL0401B-10DCKR	ACTIVE	SC70	DCK	6	3000	Green (RoHS & no Sb/Br)	CU NIPDAU	Level-1-260C-UNLIM	-40 to 125	(7UD ~ 7UV)	<a href="#">Samples</a>

(1) The marketing status values are defined as follows:

**ACTIVE:** Product device recommended for new designs.

**LIFEBUY:** TI has announced that the device will be discontinued, and a lifetime-buy period is in effect.

**NRND:** Not recommended for new designs. Device is in production to support existing customers, but TI does not recommend using this part in a new design.

**PREVIEW:** Device has been announced but is not in production. Samples may or may not be available.

**OBSOLETE:** TI has discontinued the production of the device.

(2) Eco Plan - The planned eco-friendly classification: Pb-Free (RoHS), Pb-Free (RoHS Exempt), or Green (RoHS & no Sb/Br) - please check <http://www.ti.com/productcontent> for the latest availability information and additional product content details.

**TBD:** The Pb-Free/Green conversion plan has not been defined.

**Pb-Free (RoHS):** TI's terms "Lead-Free" or "Pb-Free" mean semiconductor products that are compatible with the current RoHS requirements for all 6 substances, including the requirement that lead not exceed 0.1% by weight in homogeneous materials. Where designed to be soldered at high temperatures, TI Pb-Free products are suitable for use in specified lead-free processes.

**Pb-Free (RoHS Exempt):** This component has a RoHS exemption for either 1) lead-based flip-chip solder bumps used between the die and package, or 2) lead-based die adhesive used between the die and leadframe. The component is otherwise considered Pb-Free (RoHS compatible) as defined above.

**Green (RoHS & no Sb/Br):** TI defines "Green" to mean Pb-Free (RoHS compatible), and free of Bromine (Br) and Antimony (Sb) based flame retardants (Br or Sb do not exceed 0.1% by weight in homogeneous material)

(3) MSL, Peak Temp. - The Moisture Sensitivity Level rating according to the JEDEC industry standard classifications, and peak solder temperature.

(4) There may be additional marking, which relates to the logo, the lot trace code information, or the environmental category on the device.

(5) Multiple Device Markings will be inside parentheses. Only one Device Marking contained in parentheses and separated by a "~" will appear on a device. If a line is indented then it is a continuation of the previous line and the two combined represent the entire Device Marking for that device.

(6) Lead/Ball Finish - Orderable Devices may have multiple material finish options. Finish options are separated by a vertical ruled line. Lead/Ball Finish values may wrap to two lines if the finish value exceeds the maximum column width.

**Important Information and Disclaimer:** The information provided on this page represents TI's knowledge and belief as of the date that it is provided. TI bases its knowledge and belief on information provided by third parties, and makes no representation or warranty as to the accuracy of such information. Efforts are underway to better integrate information from third parties. TI has taken and continues to take reasonable steps to provide representative and accurate information but may not have conducted destructive testing or chemical analysis on incoming materials and chemicals. TI and TI suppliers consider certain information to be proprietary, and thus CAS numbers and other limited information may not be available for release.



In no event shall TI's liability arising out of such information exceed the total purchase price of the TI part(s) at issue in this document sold by TI to Customer on an annual basis.

## TAPE AND REEL INFORMATION



### QUADRANT ASSIGNMENTS FOR PIN 1 ORIENTATION IN TAPE



\*All dimensions are nominal

Device	Package Type	Package Drawing	Pins	SPQ	Reel Diameter (mm)	Reel Width W1 (mm)	A0 (mm)	B0 (mm)	K0 (mm)	P1 (mm)	W (mm)	Pin1 Quadrant
TPL0401A-10DCKR	SC70	DCK	6	3000	180.0	8.4	2.41	2.41	1.2	4.0	8.0	Q3
TPL0401B-10DCKR	SC70	DCK	6	3000	180.0	8.4	2.41	2.41	1.2	4.0	8.0	Q3

TAPE AND REEL BOX DIMENSIONS



\*All dimensions are nominal

Device	Package Type	Package Drawing	Pins	SPQ	Length (mm)	Width (mm)	Height (mm)
TPL0401A-10DCKR	SC70	DCK	6	3000	202.0	201.0	28.0
TPL0401B-10DCKR	SC70	DCK	6	3000	202.0	201.0	28.0

DCK (R-PDSO-G6)

PLASTIC SMALL-OUTLINE PACKAGE

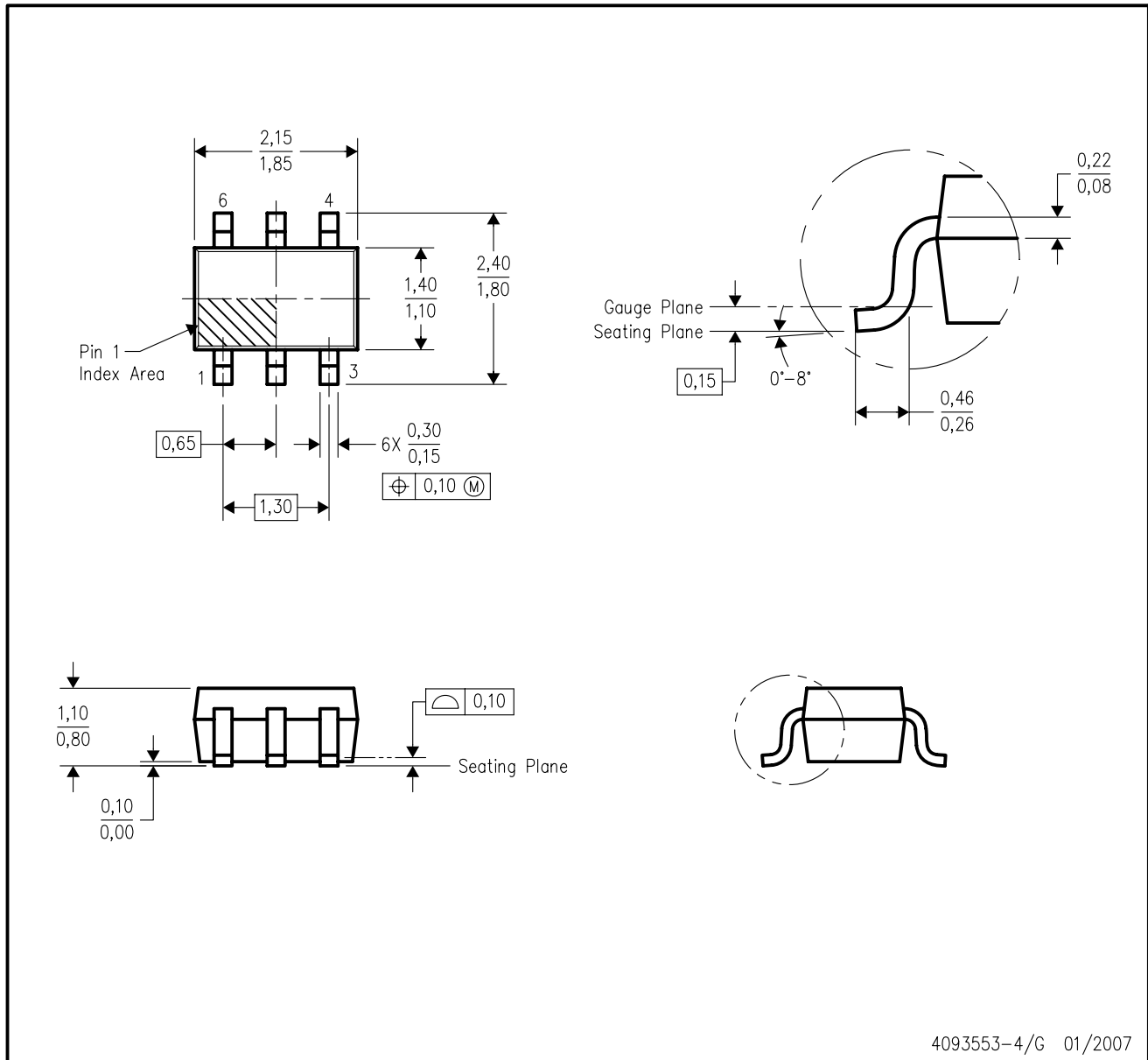

- NOTES:
- A. All linear dimensions are in millimeters.
  - B. This drawing is subject to change without notice.
  - C. Body dimensions do not include mold flash or protrusion. Mold flash and protrusion shall not exceed 0.15 per side.
  - D. Falls within JEDEC MO-203 variation AB.

DCK (R-PDSO-G6)

PLASTIC SMALL OUTLINE

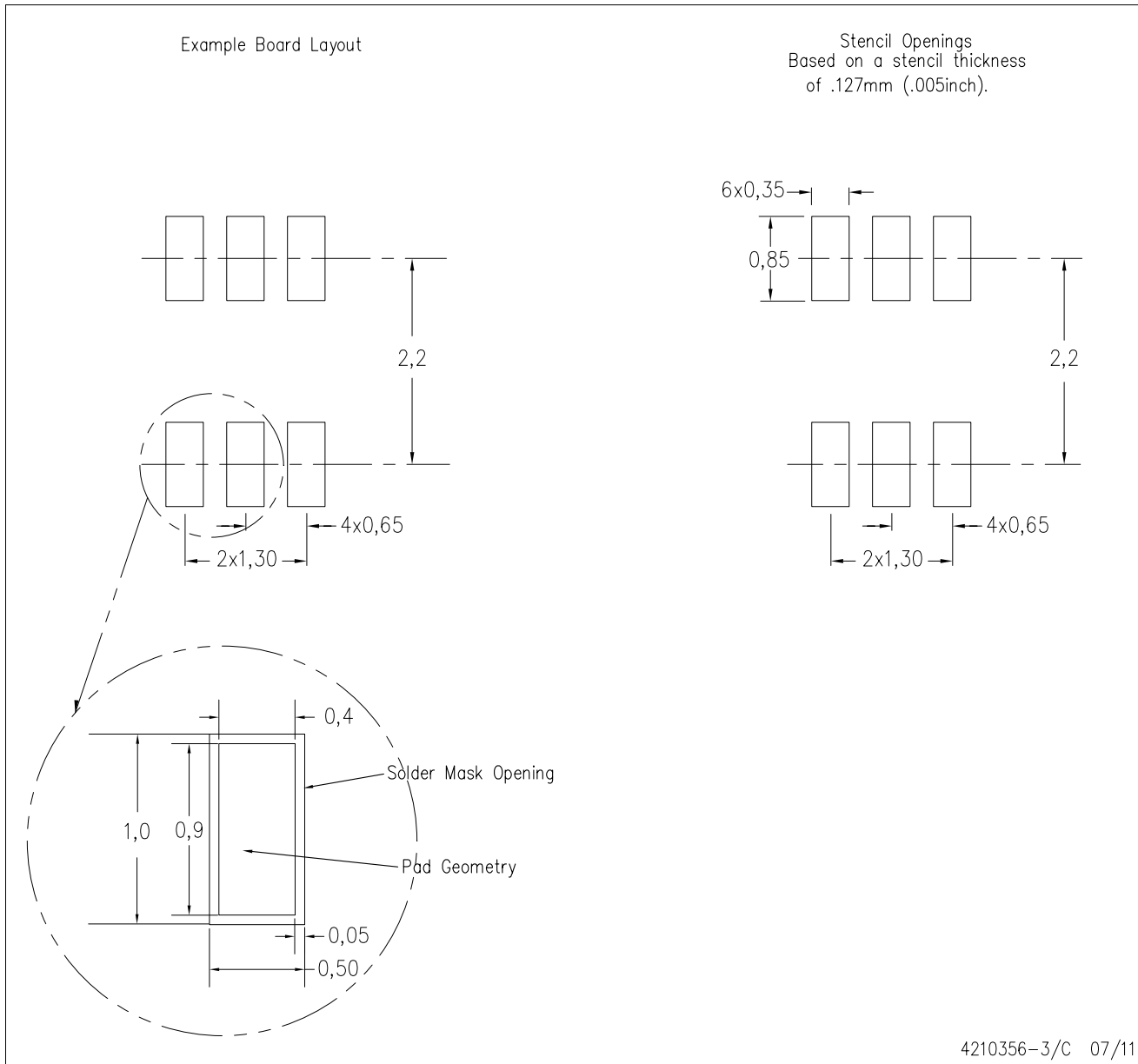

- NOTES:
- A. All linear dimensions are in millimeters.
  - B. This drawing is subject to change without notice.
  - C. Customers should place a note on the circuit board fabrication drawing not to alter the center solder mask defined pad.
  - D. Publication IPC-7351 is recommended for alternate designs.
  - E. Laser cutting apertures with trapezoidal walls and also rounding corners will offer better paste release. Customers should contact their board assembly site for stencil design recommendations. Example stencil design based on a 50% volumetric metal load solder paste. Refer to IPC-7525 for other stencil recommendations.

## IMPORTANT NOTICE

Texas Instruments Incorporated and its subsidiaries (TI) reserve the right to make corrections, enhancements, improvements and other changes to its semiconductor products and services per JESD46, latest issue, and to discontinue any product or service per JESD48, latest issue. Buyers should obtain the latest relevant information before placing orders and should verify that such information is current and complete. All semiconductor products (also referred to herein as "components") are sold subject to TI's terms and conditions of sale supplied at the time of order acknowledgment.

TI warrants performance of its components to the specifications applicable at the time of sale, in accordance with the warranty in TI's terms and conditions of sale of semiconductor products. Testing and other quality control techniques are used to the extent TI deems necessary to support this warranty. Except where mandated by applicable law, testing of all parameters of each component is not necessarily performed.

TI assumes no liability for applications assistance or the design of Buyers' products. Buyers are responsible for their products and applications using TI components. To minimize the risks associated with Buyers' products and applications, Buyers should provide adequate design and operating safeguards.

TI does not warrant or represent that any license, either express or implied, is granted under any patent right, copyright, mask work right, or other intellectual property right relating to any combination, machine, or process in which TI components or services are used. Information published by TI regarding third-party products or services does not constitute a license to use such products or services or a warranty or endorsement thereof. Use of such information may require a license from a third party under the patents or other intellectual property of the third party, or a license from TI under the patents or other intellectual property of TI.

Reproduction of significant portions of TI information in TI data books or data sheets is permissible only if reproduction is without alteration and is accompanied by all associated warranties, conditions, limitations, and notices. TI is not responsible or liable for such altered documentation. Information of third parties may be subject to additional restrictions.

Resale of TI components or services with statements different from or beyond the parameters stated by TI for that component or service voids all express and any implied warranties for the associated TI component or service and is an unfair and deceptive business practice. TI is not responsible or liable for any such statements.

Buyer acknowledges and agrees that it is solely responsible for compliance with all legal, regulatory and safety-related requirements concerning its products, and any use of TI components in its applications, notwithstanding any applications-related information or support that may be provided by TI. Buyer represents and agrees that it has all the necessary expertise to create and implement safeguards which anticipate dangerous consequences of failures, monitor failures and their consequences, lessen the likelihood of failures that might cause harm and take appropriate remedial actions. Buyer will fully indemnify TI and its representatives against any damages arising out of the use of any TI components in safety-critical applications.

In some cases, TI components may be promoted specifically to facilitate safety-related applications. With such components, TI's goal is to help enable customers to design and create their own end-product solutions that meet applicable functional safety standards and requirements. Nonetheless, such components are subject to these terms.

No TI components are authorized for use in FDA Class III (or similar life-critical medical equipment) unless authorized officers of the parties have executed a special agreement specifically governing such use.

Only those TI components which TI has specifically designated as military grade or "enhanced plastic" are designed and intended for use in military/aerospace applications or environments. Buyer acknowledges and agrees that any military or aerospace use of TI components which have **not** been so designated is solely at the Buyer's risk, and that Buyer is solely responsible for compliance with all legal and regulatory requirements in connection with such use.

TI has specifically designated certain components as meeting ISO/TS16949 requirements, mainly for automotive use. In any case of use of non-designated products, TI will not be responsible for any failure to meet ISO/TS16949.

### Products

Audio	<a href="http://www.ti.com/audio">www.ti.com/audio</a>
Amplifiers	<a href="http://amplifier.ti.com">amplifier.ti.com</a>
Data Converters	<a href="http://dataconverter.ti.com">dataconverter.ti.com</a>
DLP® Products	<a href="http://www.dlp.com">www.dlp.com</a>
DSP	<a href="http://dsp.ti.com">dsp.ti.com</a>
Clocks and Timers	<a href="http://www.ti.com/clocks">www.ti.com/clocks</a>
Interface	<a href="http://interface.ti.com">interface.ti.com</a>
Logic	<a href="http://logic.ti.com">logic.ti.com</a>
Power Mgmt	<a href="http://power.ti.com">power.ti.com</a>
Microcontrollers	<a href="http://microcontroller.ti.com">microcontroller.ti.com</a>
RFID	<a href="http://www.ti-rfid.com">www.ti-rfid.com</a>
OMAP Applications Processors	<a href="http://www.ti.com/omap">www.ti.com/omap</a>
Wireless Connectivity	<a href="http://www.ti.com/wirelessconnectivity">www.ti.com/wirelessconnectivity</a>

### Applications

Automotive and Transportation	<a href="http://www.ti.com/automotive">www.ti.com/automotive</a>
Communications and Telecom	<a href="http://www.ti.com/communications">www.ti.com/communications</a>
Computers and Peripherals	<a href="http://www.ti.com/computers">www.ti.com/computers</a>
Consumer Electronics	<a href="http://www.ti.com/consumer-apps">www.ti.com/consumer-apps</a>
Energy and Lighting	<a href="http://www.ti.com/energy">www.ti.com/energy</a>
Industrial	<a href="http://www.ti.com/industrial">www.ti.com/industrial</a>
Medical	<a href="http://www.ti.com/medical">www.ti.com/medical</a>
Security	<a href="http://www.ti.com/security">www.ti.com/security</a>
Space, Avionics and Defense	<a href="http://www.ti.com/space-avionics-defense">www.ti.com/space-avionics-defense</a>
Video and Imaging	<a href="http://www.ti.com/video">www.ti.com/video</a>

### TI E2E Community

[e2e.ti.com](http://e2e.ti.com)