

EVALUATION KIT
AVAILABLE

Dual, 256-Tap, Volatile, Low-Voltage, Linear Taper Digital Potentiometer

MAX5392

General Description

The MAX5392 dual, 256-tap, volatile, low-voltage, linear taper digital potentiometer offers three end-to-end resistance values of 10k Ω , 50k Ω , and 100k Ω . Operating from a single +1.7V to +5.5V power supply, the device provides a low 35ppm/ $^{\circ}$ C end-to-end temperature coefficient. The device features an I²C interface.

The small package size, low supply operating voltage, low supply current, and automotive temperature range of the MAX5392 makes the device uniquely suited for the portable consumer market, battery-backup industrial applications, and the automotive market.

The MAX5392 is specified over the automotive -40 $^{\circ}$ C to +125 $^{\circ}$ C temperature range and is available in a 16-pin TSSOP package.

Applications

Low-Voltage Battery Applications
 Portable Electronics
 Mechanical Potentiometer Replacement
 Offset and Gain Control
 Adjustable Voltage References/Linear Regulators
 Automotive Electronics

Features

- ◆ Dual, 256-Tap Linear Taper Positions
- ◆ Single +1.7V to +5.5V Supply Operation
- ◆ Low 12 μ A Quiescent Supply Current
- ◆ 10k Ω , 50k Ω , 100k Ω End-to-End Resistance Values
- ◆ I²C-Compatible Interface
- ◆ Wiper Set to Midscale on Power-Up
- ◆ -40 $^{\circ}$ C to +125 $^{\circ}$ C Operating Temperature Range

Ordering Information

PART	PIN-PACKAGE	END-TO-END RESISTANCE (k Ω)
MAX5392LAUE+	16 TSSOP	10
MAX5392MAUE+	16 TSSOP	50
MAX5392NAUE+	16 TSSOP	100

Note: All devices are specified over the -40 $^{\circ}$ C to +125 $^{\circ}$ C operating temperature range.

+ Denotes a lead(Pb)-free/RoHS-compliant package.

Functional Diagram

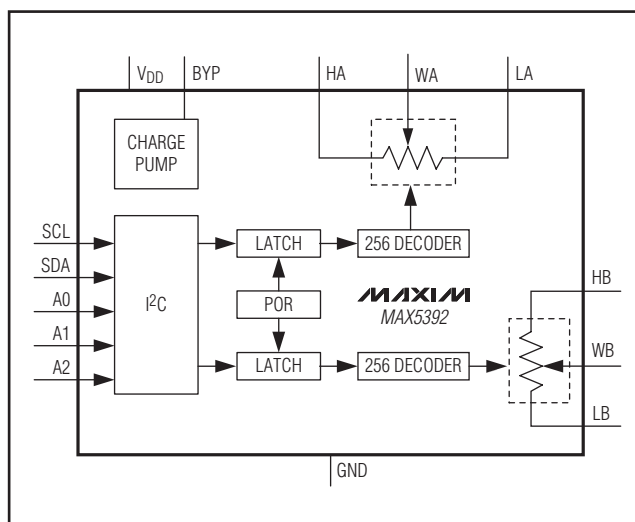

Dual, 256-Tap, Volatile, Low-Voltage, Linear Taper Digital Potentiometer

ABSOLUTE MAXIMUM RATINGS

V _{DD} to GND	-0.3V to +6V	Continuous Power Dissipation (T _A = +70°C)
H ₋ , W ₋ , L ₋ to GND	-0.3V to the lower of (V _{DD} + 0.3V) and +6V	16-Pin TSSOP (derate 11.1mW/°C above +70°C) ...888.9mW
All Other Pins to GND	-0.3V to +6V	Operating Temperature Range
Continuous Current in to H ₋ , W ₋ , and L ₋		Junction Temperature
MAX5392L	±5mA	Storage Temperature Range.....
MAX5392M	±2mA	Lead Temperature (soldering, 10s)
MAX5392N.....	±1mA	Soldering Temperature (reflow)

Stresses beyond those listed under "Absolute Maximum Ratings" may cause permanent damage to the device. These are stress ratings only, and functional operation of the device at these or any other conditions beyond those indicated in the operational sections of the specifications is not implied. Exposure to absolute maximum rating conditions for extended periods may affect device reliability.

ELECTRICAL CHARACTERISTICS

(V_{DD} = +1.7V to +5.5V, V_{H-} = V_{DD}, V_{L-} = 0, T_A = T_{MIN} to T_{MAX}, unless otherwise noted. Typical values are at V_{DD} = +1.8V, T_A = +25°C.) (Note 1)

PARAMETER	SYMBOL	CONDITIONS	MIN	TYP	MAX	UNITS	
Resolution	N		256			Tap	
DC PERFORMANCE (Voltage Divider Mode)							
Integral Nonlinearity	INL	(Note 2)	-0.5		+0.5	LSB	
Differential Nonlinearity	DNL	(Note 2)	-0.5		+0.5	LSB	
Dual Code Matching		Register A = Register B	-0.5		+0.5	LSB	
Ratiometric Resistor Tempco		($\Delta V_W/V_W$)/ ΔT , no load		5		ppm/°C	
Full-Scale Error		Code = FFh	MAX5392L	-3	-2.2	LSB	
			MAX5392M	-1	-0.6		
			MAX5392N	-0.5	-0.3		
Zero-Scale Error		Code = 00h	MAX5392L		2.2	3	LSB
			MAX5392M		0.6	1.0	
			MAX5392N		0.3	0.5	
DC PERFORMANCE (Variable Resistor Mode)							
Integral Nonlinearity	R-INL	MAX5392L (Note 3)	-1.5		+1.5	LSB	
		MAX5392M (Note 3)	-0.75		+0.75		
		MAX5392N (Note 3)	-0.5		+0.5		
Differential Nonlinearity	R-DNL	(Note 3)	-0.5		+0.5	LSB	
DC PERFORMANCE (Resistor Characteristics)							
Wiper Resistance	R _{WL}	(Note 4)			200	Ω	
Terminal Capacitance	C _{H-} , C _{L-}	Measured to GND		10		pF	
Wiper Capacitance	C _{W-}	Measured to GND		50		pF	
End-to-End Resistor Tempco	TCR	No load		35		ppm/°C	
End-to-End Resistor Tolerance	ΔR_{HL}	Wiper not connected	-25		+25	%	

Dual, 256-Tap, Volatile, Low-Voltage, Linear Taper Digital Potentiometer

MAX5392

ELECTRICAL CHARACTERISTICS (continued)

(V_{DD} = +1.7V to +5.5V, V_{H_} = V_{DD}, V_{L_} = 0, T_A = T_{MIN} to T_{MAX}, unless otherwise noted. Typical values are at V_{DD} = +1.8V, T_A = +25°C.) (Note 1)

PARAMETER	SYMBOL	CONDITIONS	MIN	TYP	MAX	UNITS
AC PERFORMANCE						
Crosstalk		(Note 5)		-90		dB
-3dB Bandwidth	BW	Code = 80H, 10pF load, V _{DD} = 1.8V	MAX5392L	600		kHz
			MAX5392M	100		
			MAX5392N	50		
Total Harmonic Distortion Plus Noise	THD+N	Measured at W, V _{H_} = 1V _{RMS} at 1kHz		0.02		%
Wiper Settling Time	t _S	(Note 6)	MAX5392L	400		ns
			MAX5392M	1200		
			MAX5392N	2200		
Charge-Pump Feedthrough at W ₋	VRW	f _{CLK} = 600kHz, C _{BYP} = 0nF			600	nV _{P-P}
POWER SUPPLIES						
Supply Voltage Range	V _{DD}		1.7		5.5	V
Standby Current		V _{DD} = 5.5V		27		μA
		V _{DD} = 1.7V		12		
DIGITAL INPUTS						
Minimum Input High Voltage	V _{IH}	V _{DD} = 2.6V to 5.5V	70			% × V _{DD}
		V _{DD} = 1.7V to 2.6V	75			
Maximum Input Low Voltage	V _{IL}	V _{DD} = 2.6V to 5.5V			30	% × V _{DD}
		V _{DD} = 1.7V to 2.6V			25	
Input Leakage Current			-1		+1	μA
Input Capacitance				5		pF
TIMING CHARACTERISTICS—I²C (Notes 7 and 8)						
Maximum SCL Frequency	f _{SCL}				400	kHz
Setup Time for START Condition	t _{SU:STA}		0.6			μs
Hold Time for START Condition	t _{HD:STA}		0.6			μs
SCL High Time	t _{HIGH}		0.6			μs
SCL Low Time	t _{LOW}		1.3			μs

Dual, 256-Tap, Volatile, Low-Voltage, Linear Taper Digital Potentiometer

ELECTRICAL CHARACTERISTICS (continued)

($V_{DD} = +1.7V$ to $+5.5V$, $V_{H_} = V_{DD}$, $V_{L_} = 0$, $T_A = T_{MIN}$ to T_{MAX} , unless otherwise noted. Typical values are at $V_{DD} = +1.8V$, $T_A = +25^{\circ}C$.) (Note 1)

PARAMETER	SYMBOL	CONDITIONS	MIN	TYP	MAX	UNITS
Data Setup Time	$t_{SU:DAT}$		100			ns
Data Hold Time	$t_{HD:DAT}$		0			μs
SDA, SCL Rise Time	t_R				0.3	μs
SDA, SCL Fall	t_F				0.3	μs
Setup Time for STOP Condition	$t_{SU:STO}$		0.6			μs
Bus Free Time Between STOP and START Condition	t_{BUF}	Minimum power-up rate = $0.2V/\mu s$	1.3			μs
Pulse Suppressed Spike Width	t_{SP}				50	ns
Capacitive Load for Each Bus	CB	(Note 9)			400	pF

Note 1: All devices are 100% production tested at $T_A = +25^{\circ}C$. Specifications over temperature limits are guaranteed by design and characterization.

Note 2: DNL and INL are measured with the potentiometer configured as a voltage-divider (Figure 1) with $H_ = V_{DD}$ and $L_ = GND$. The wiper terminal is unloaded and measured with a high-input-impedance voltmeter.

Note 3: R-DNL and R-INL are measured with the potentiometer configured as a variable resistor (Figure 1). DNL and INL are measured with the potentiometer configured as a variable resistor. $H_$ is unconnected and $L_ = GND$. For $V_{DD} = +5V$, the wiper terminal is driven with a source current of $400\mu A$ for the $10k\Omega$ configuration, $80\mu A$ for the $50k\Omega$ configuration, and $40\mu A$ for the $100k\Omega$ configuration. For $V_{DD} = +1.7V$, the wiper terminal is driven with a source current of $150\mu A$ for the $10k\Omega$ configuration, $30\mu A$ for the $50k\Omega$ configuration, and $15\mu A$ for the $100k\Omega$ configuration.

Note 4: The wiper resistance is the worst value measured by injecting the currents given in Note 3 to $W_$ with $L_ = GND$. $R_{W_} = (V_{W_} - V_{H_})/I_{W_}$.

Note 5: Drive HA with a 1kHz GND to V_{DD} amplitude tone. $LA = LB = GND$. No load. WB is at midscale with a 10pF load. Measure WB.

Note 6: The wiper-settling time is the worst-case 0 to 50% rise time, measured between tap 0 and tap 127. $H_ = V_{DD}$, $L_ = GND$, and the wiper terminal is loaded with 10pF capacitance to ground.

Note 7: Digital timing is guaranteed by design and characterization, not production tested.

Note 8: The SCL clock period includes rise and fall times ($t_R = t_F$). All digital input signals are specified with $t_R = t_F = 2ns$ and timed from a voltage level of $(V_{IL} + V_{IH})/2$.

Note 9: An appropriate bus pullup resistance must be selected depending on board capacitance. For I²C-bus specification information from NXP Semiconductor (formerly Philips Semiconductor), refer to the UM10204: I²C-Bus Specification and User Manual.

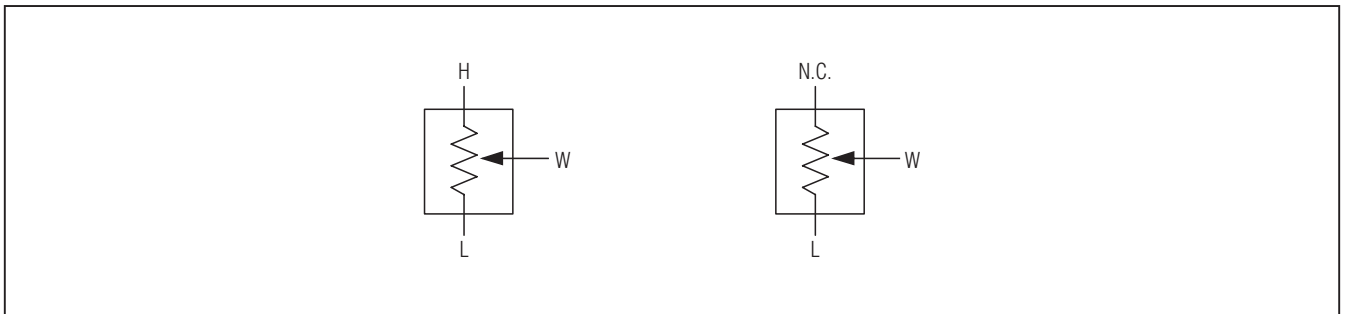

Figure 1. Voltage-Divider and Variable Resistor Configurations

Dual, 256-Tap, Volatile, Low-Voltage, Linear Taper Digital Potentiometer

Typical Operating Characteristics

($V_{DD} = 1.8V$, $T_A = +25^\circ C$, unless otherwise noted.)

MAX5392

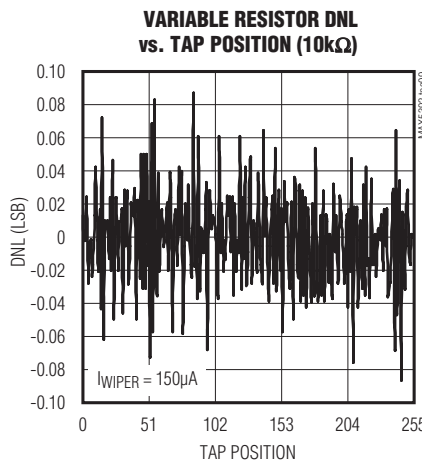
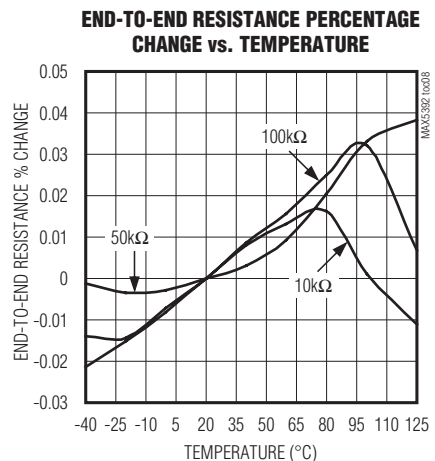
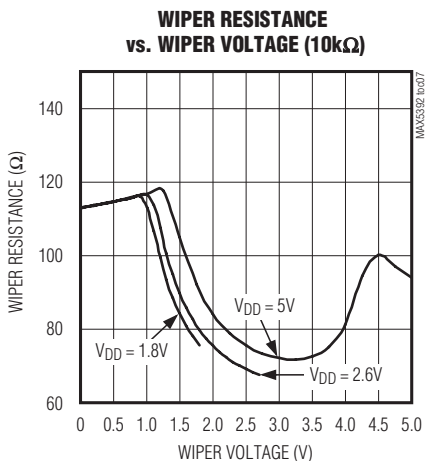
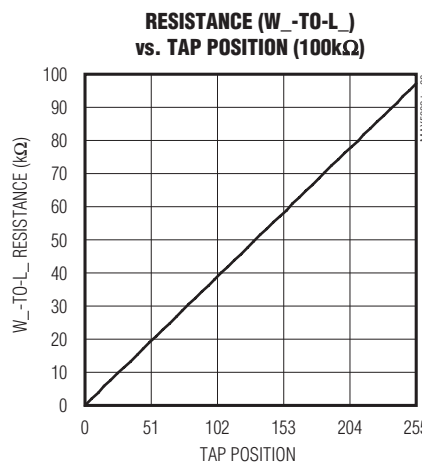
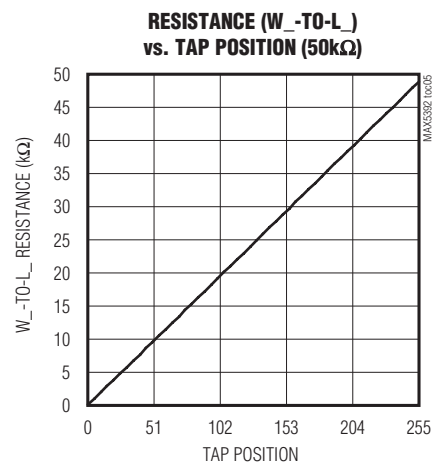
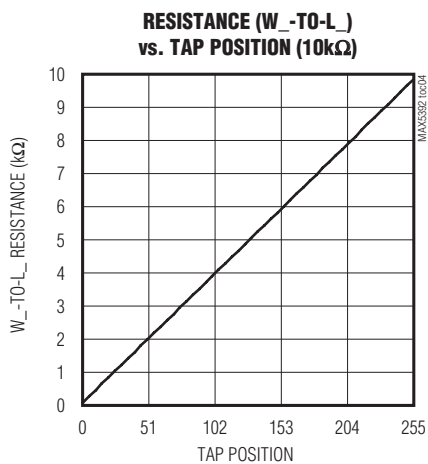
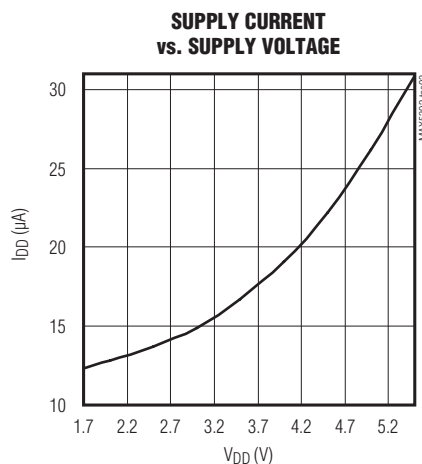
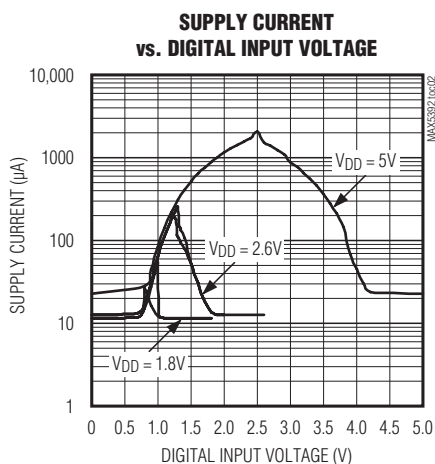
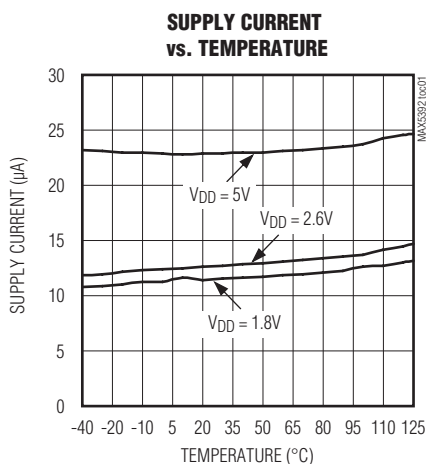

Dual, 256-Tap, Volatile, Low-Voltage, Linear Taper Digital Potentiometer

Typical Operating Characteristics (continued)

($V_{DD} = 1.8V$, $T_A = +25^\circ C$, unless otherwise noted.)

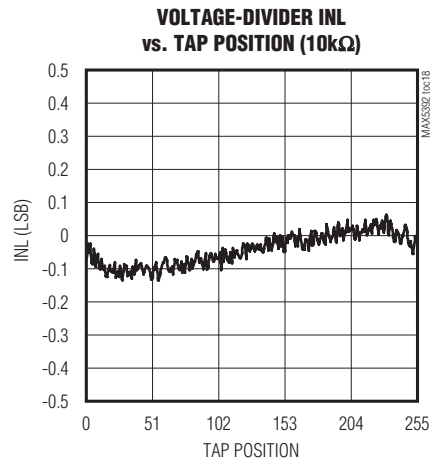
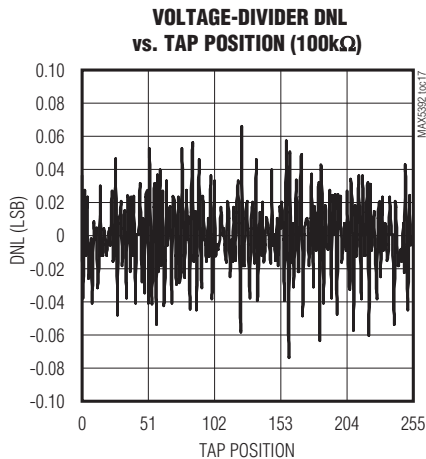
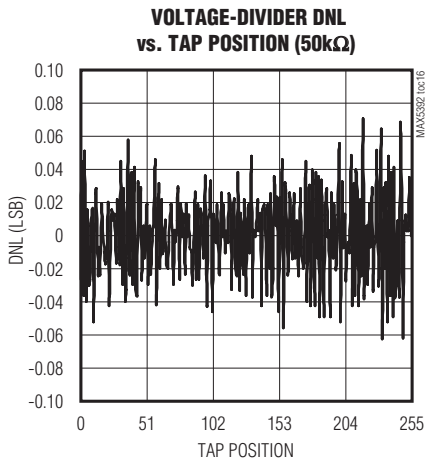
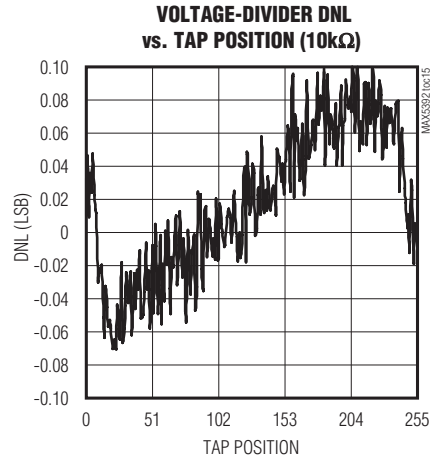
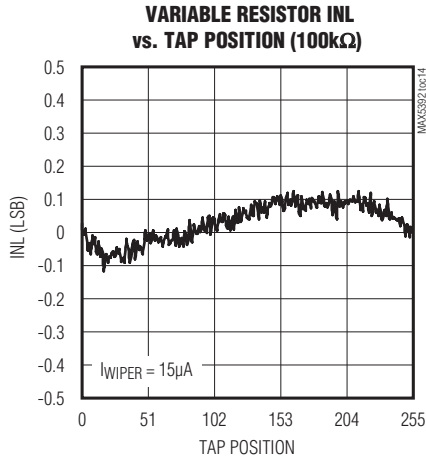
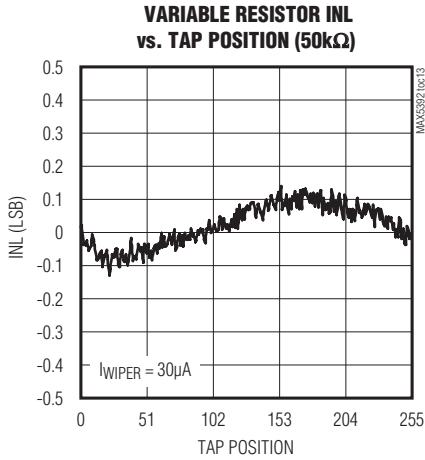
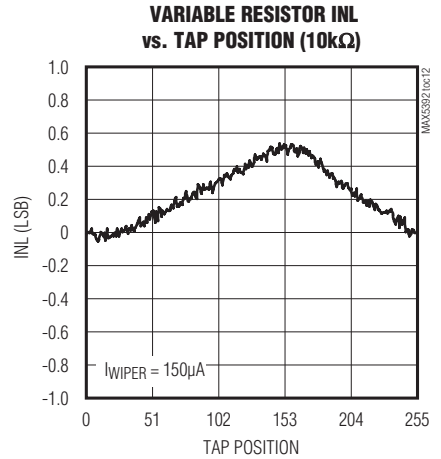
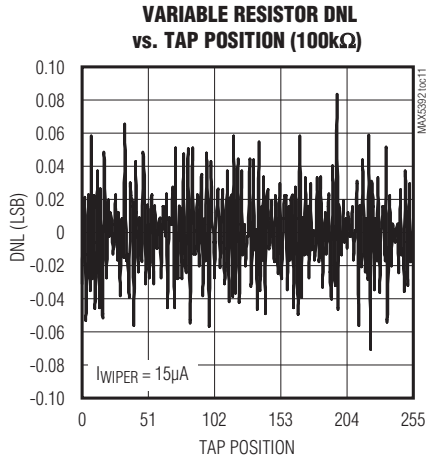
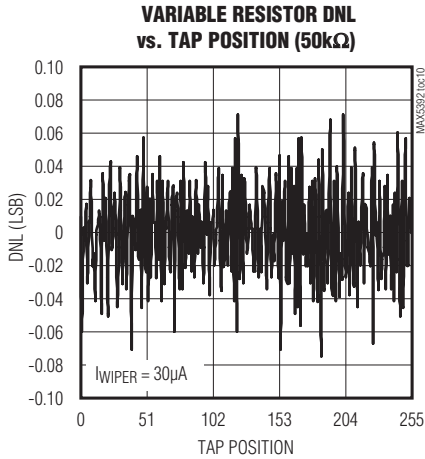

Dual, 256-Tap, Volatile, Low-Voltage, Linear Taper Digital Potentiometer

MAX5392

Typical Operating Characteristics (continued)

($V_{DD} = 1.8V$, $T_A = +25^\circ C$, unless otherwise noted.)

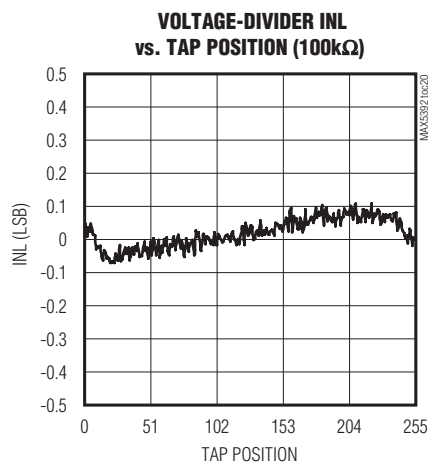
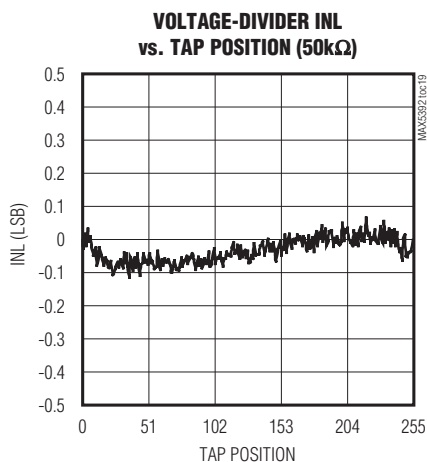

TAP-TO-TAP SWITCHING TRANSIENT (CODE 127 TO 128) 10k Ω
MAX5392 toc21

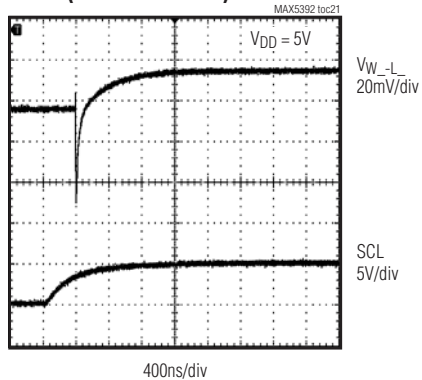

TAP-TO-TAP SWITCHING TRANSIENT (CODE 127 TO 128) 50k Ω
MAX5392 toc22

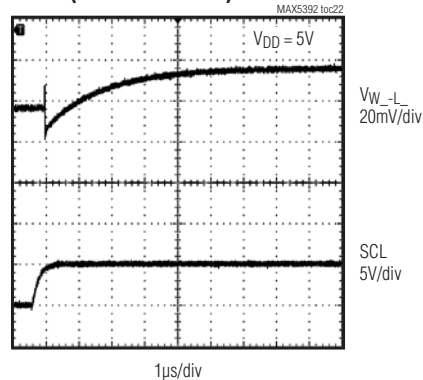

TAP-TO-TAP SWITCHING TRANSIENT (CODE 127 TO 128) 100k Ω
MAX5392 toc23

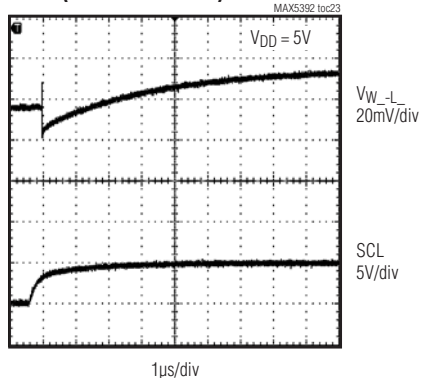

POWER-ON TRANSIENT (50k Ω)
MAX5392 toc24

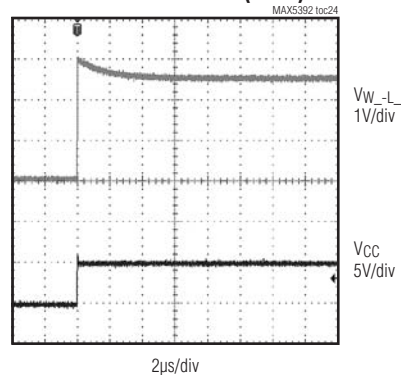

Dual, 256-Tap, Volatile, Low-Voltage, Linear Taper Digital Potentiometer

Typical Operating Characteristics (continued)

($V_{DD} = 1.8V$, $T_A = +25^\circ C$, unless otherwise noted.)

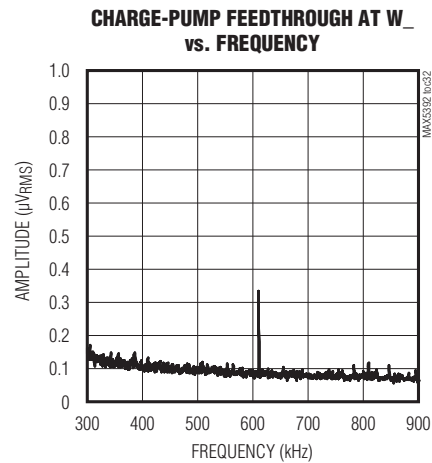
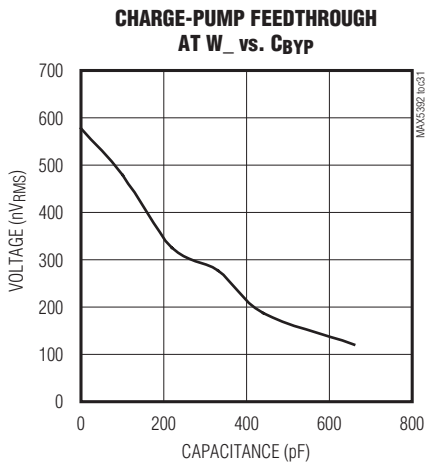
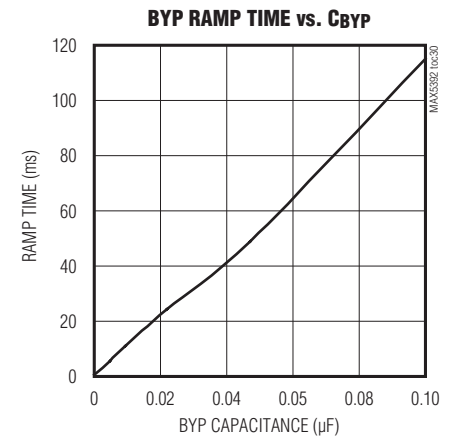
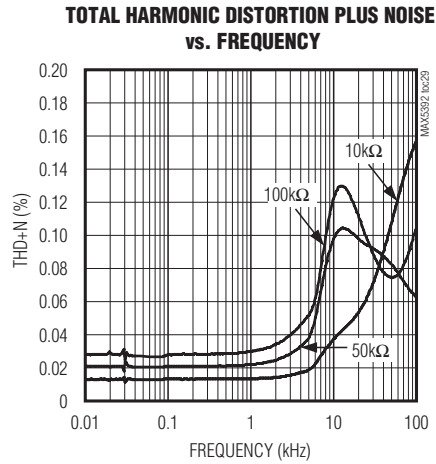
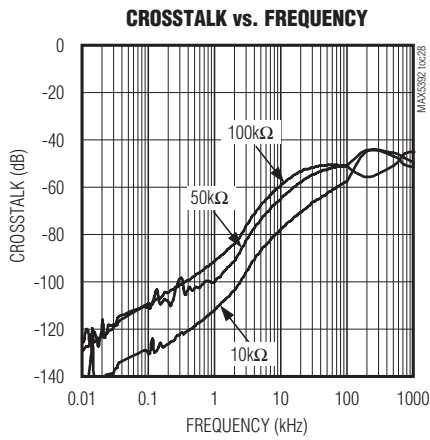
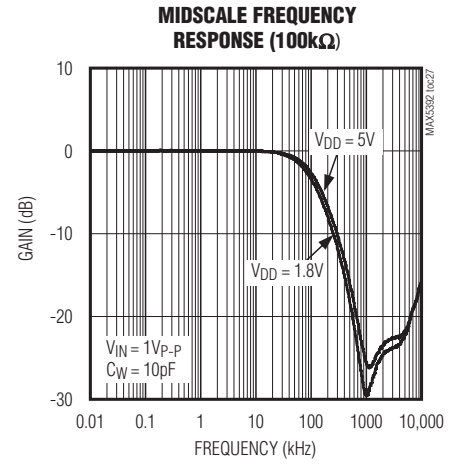
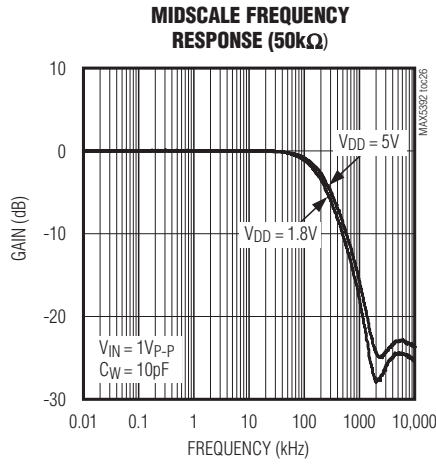
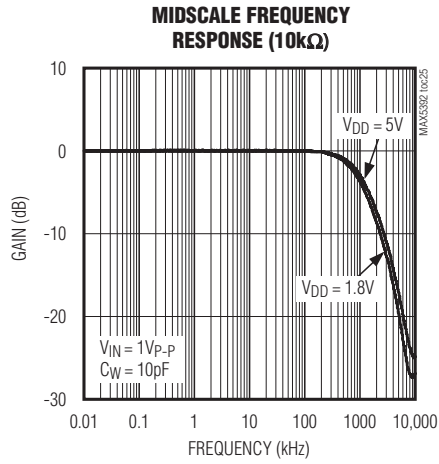

Dual, 256-Tap, Volatile, Low-Voltage, Linear Taper Digital Potentiometer

Pin Configuration

MAX5392

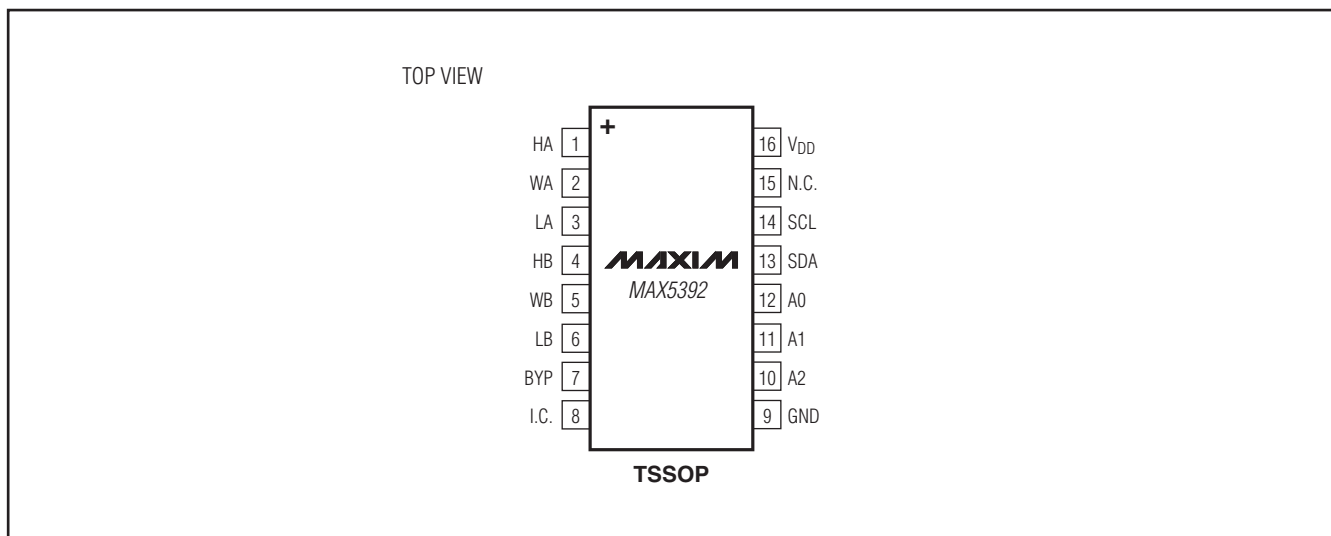

Pin Description

PIN	NAME	FUNCTION
1	HA	Resistor A High Terminal. The voltage at HA can be higher or lower than the voltage at LA. Current can flow into or out of HA.
2	WA	Resistor A Wiper Terminal
3	LA	Resistor A Low Terminal. The voltage at LA can be higher or lower than the voltage at HA. Current can flow into or out of LA.
4	HB	Resistor B High Terminal. The voltage at HB can be higher or lower than the voltage at LB. Current can flow into or out of HB.
5	WB	Resistor B Wiper Terminal
6	LB	Resistor B Low Terminal. The voltage at LB can be higher or lower than the voltage at HB. Current can flow into or out of LB.
7	BYP	Internal Power-Supply Bypass. For additional charge-pump filtering, bypass to GND with a capacitor close to the device.
8	I.C.	Internally Connected. Connect to GND.
9	GND	Ground
10	A2	Address Input 2. Connect to V _{DD} or GND.
11	A1	Address Input 1. Connect to V _{DD} or GND.
12	A0	Address Input 0. Connect to V _{DD} or GND.
13	SDA	I ² C-Compatible Serial-Data Input/Output. A pullup resistor is required.
14	SCL	I ² C-Compatible Serial-Clock Input. A pullup resistor is required.
15	N.C.	No Connection. Not internally connected.
16	V _{DD}	Power-Supply Input. Bypass V _{DD} to GND with a 0.1μF capacitor close to the device.

Dual, 256-Tap, Volatile, Low-Voltage, Linear Taper Digital Potentiometer

Detailed Description

The MAX5392 dual, 256-tap, volatile, low-voltage linear taper digital potentiometer offers three end-to-end resistance values of 10k Ω , 50k Ω , and 100k Ω . The potentiometer consists of 255 fixed resistors in series between terminals H₋ and L₋. The potentiometer wiper, W₋, is programmable to access any one of the 256 tap points on the resistor string.

The potentiometers are programmable independently of each other. The MAX5392 features an I²C interface.

Charge Pump

The MAX5392 contains an internal charge pump that guarantees the maximum wiper resistance, R_{WL}, to be less than 200 Ω for supply voltages down to 1.7V. Pins H₋, W₋, and L₋ are still required to be less than V_{DD} + 0.3V. A bypass input, BYP, is provided to allow additional filtering of the charge-pump output, further reducing clock feedthrough that can occur on H₋, W₋, or L₋. The nominal clock rate of the charge pump is 600kHz. BYP should remain resistively unloaded as any additional load would increase clock feedthrough. See the Charge-Pump Feedthrough at W₋ vs. CBYP graph in the *Typical Operating Characteristics* for CBYP sizing guidelines with respect to clock feedthrough to the wiper. The value of CBYP does affect the startup time of the charge

pump; however, CBYP does not impact the ability to communicate with the device, nor is there a minimum CBYP requirement. The maximum wiper impedance specification is not guaranteed until the charge pump is fully settled. See the BYP Ramp Time vs. CBYP graph in the *Typical Operating Characteristics* for CBYP impact on charge-pump settling time.

I²C Digital Interface

The I²C interface contains a shift register that decodes the command and address bytes, routing the data to the appropriate control registers. Data written to a control register immediately updates the wiper position. The wipers A and B power up in midposition, D[7:0] = 80h.

Serial Addressing

The MAX5392 operates as a slave device that receives data through an I²C/SMBus™-compatible 2-wire serial interface. The interface uses a serial-data access line (SDA) and a serial-clock line (SCL) to achieve bidirectional communication between master(s) and slave(s). A master, typically a microcontroller, initiates all data transfers to the port and generates the SCL clock that synchronizes the data transfer. See Figure 2. Connect a pullup resistor, typically 4.7k Ω , between each of the SDA and SCL lines to a voltage between V_{DD} and 5.5V.

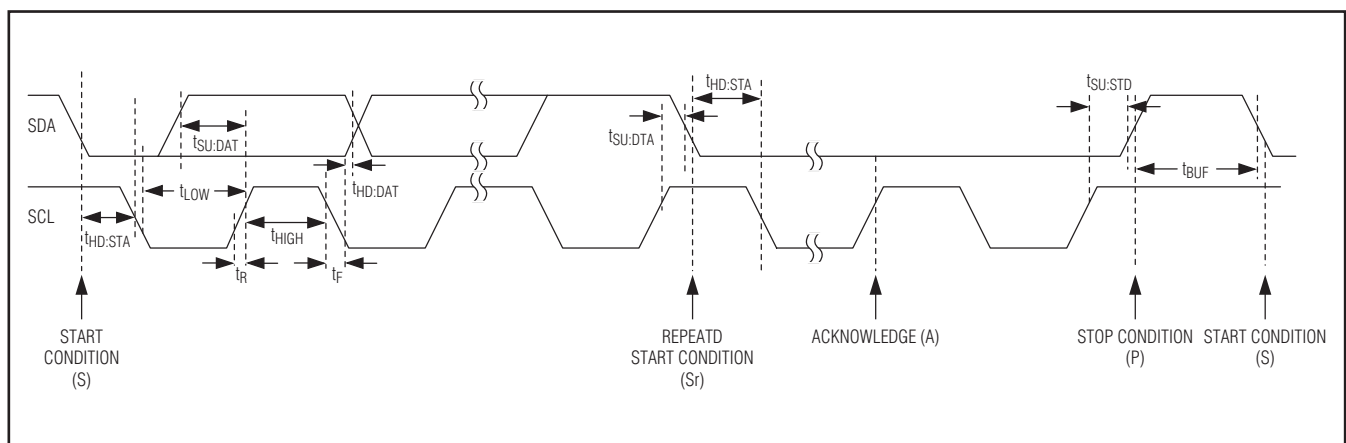

Figure 2. I²C Serial-Interface Timing Diagram

SMBus is a trademark of Intel Corp.

Dual, 256-Tap, Volatile, Low-Voltage, Linear Taper Digital Potentiometer

Each transmission consists of a START (S) condition sent by a master, followed by a 7-bit slave address plus a NOP/ \bar{W} bit. See Figures 3, 4, and 7.

START and STOP Conditions

SCL and SDA remain high when the interface is inactive. A master controller signals the beginning of a transmission with a START condition by transitioning SDA from high to low while SCL is high. The master controller issues a STOP condition by transitioning the SDA from low to high while SCL is high, after finishing communicating with the slave. The bus is then free for another transmission. See Figure 2.

Bit Transfer

One data bit is transferred during each clock pulse. The data on the SDA line must remain stable while SCL is high. See Figure 5.

Acknowledge

The acknowledge bit is a clocked 9th bit that the recipient uses to handshake receipt of each byte of data. See Figure 6. Each byte transferred requires a total of 9 bits. The master controller generates the 9th clock pulse, and the recipient pulls down SDA during the acknowledge clock pulse, so the SDA line remains stable low during the high period of the clock pulse.

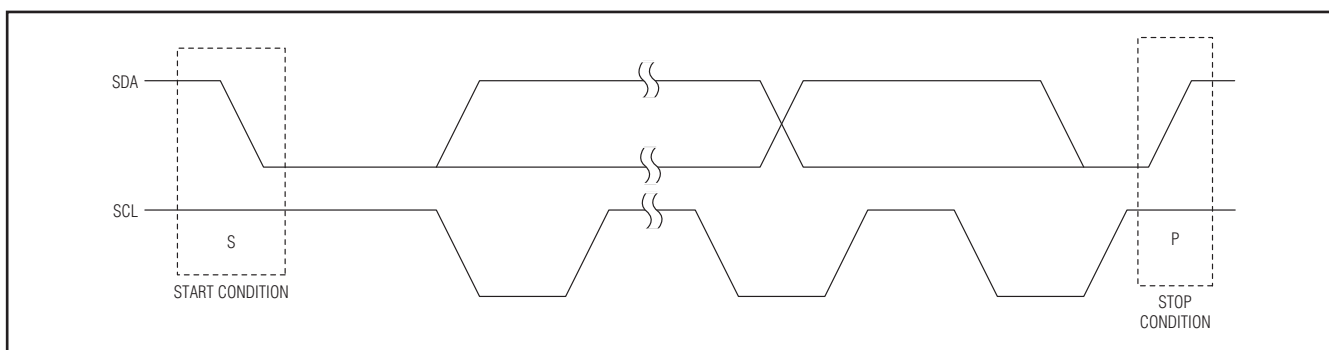

Figure 3. START and STOP Conditions

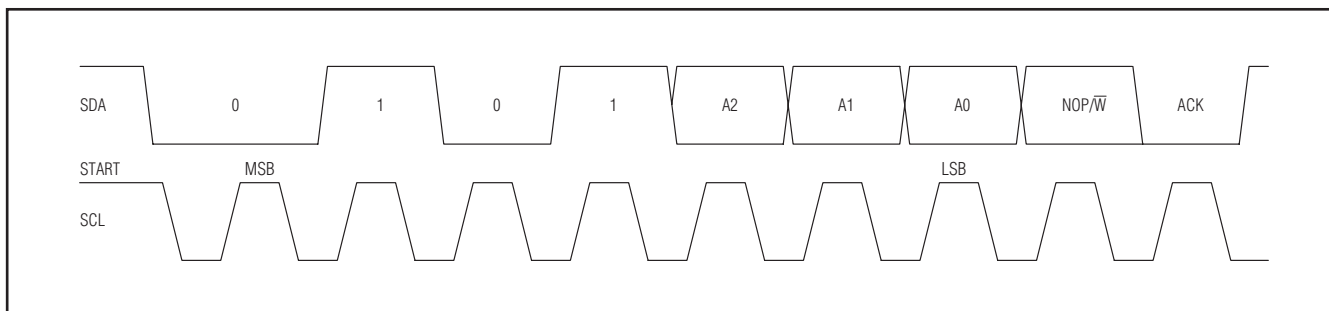

Figure 4. Slave Address

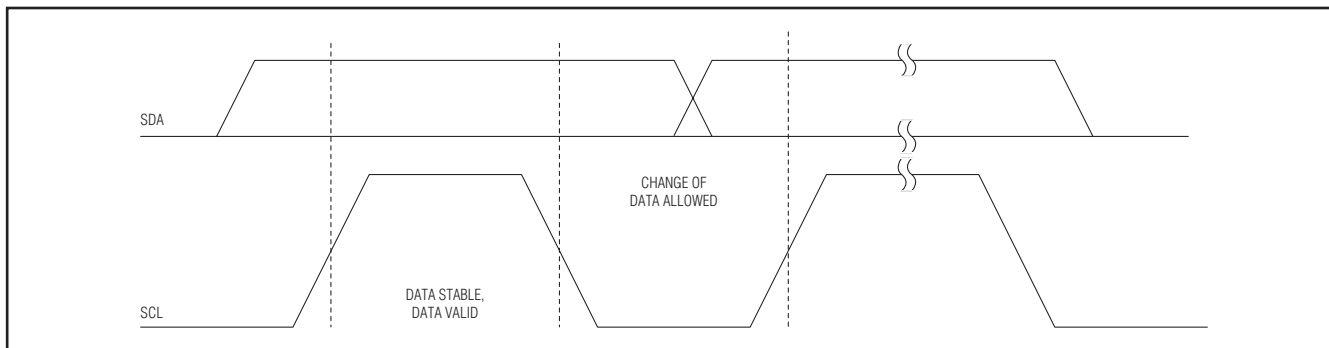

Figure 5. Bit Transfer

Dual, 256-Tap, Volatile, Low-Voltage, Linear Taper Digital Potentiometer

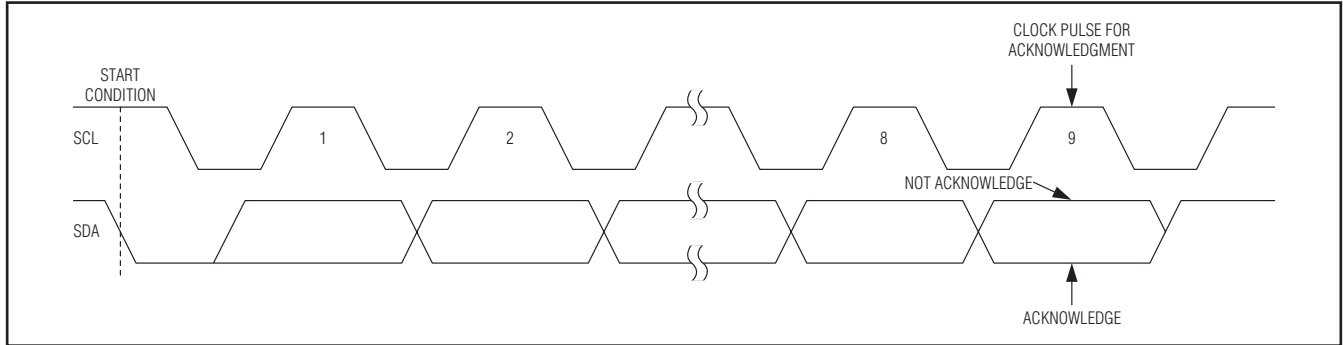

Figure 6. Acknowledge

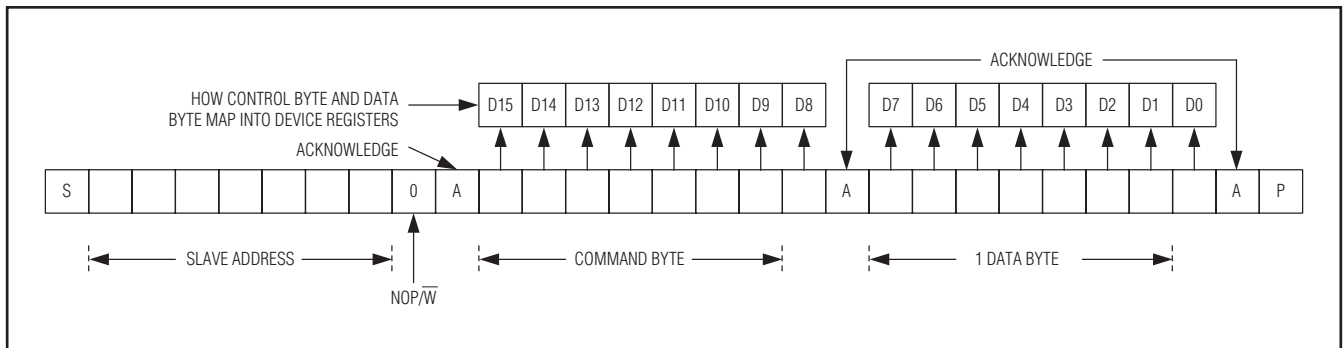

Figure 7. Command and Single Data Byte Received

Slave Address

The MAX5392 includes a 7-bit slave address (Figure 4). The 8th bit following the 7th bit of the slave address is the $\text{NOP}/\overline{\text{W}}$ bit. Set the $\text{NOP}/\overline{\text{W}}$ bit low for a write command and high for a no-operation command. The device does not support readback.

The device provides three address inputs (A0, A1, and A2), allowing up to eight devices to share a common bus (Table 1). The first 4 bits (MSBs) of the factory-set slave addresses are always 0101. A2, A1, and A0 set the next 3 bits of the slave address. Connect each address input to V_{DD} or GND. Each device must have a unique address to share a common bus.

Message Format for Writing

Write to the devices by transmitting the device's slave address with $\text{NOP}/\overline{\text{W}}$ (8th bit) set to zero, followed by at least 2 bytes of information. The first byte of informa-

tion is the command byte. The second byte is the data byte. The data byte goes into the internal register of the device as selected by the command byte (Figure 7 and Table 2).

Table 1. Slave Addresses

ADDRESS INPUTS			SLAVE ADDRESS
A2	A1	A0	
GND	GND	GND	0101000
GND	GND	V_{DD}	0101001
GND	V_{DD}	GND	0101010
GND	V_{DD}	V_{DD}	0101011
V_{DD}	GND	GND	0101100
V_{DD}	GND	V_{DD}	0101101
V_{DD}	V_{DD}	GND	0101110
V_{DD}	V_{DD}	V_{DD}	0101111

Dual, 256-Tap, Volatile, Low-Voltage, Linear Taper Digital Potentiometer

Table 2. I²C Command Byte Summary

SCL CYCLE NUMBER	START (S)	ADDRESS BYTE								COMMAND BYTE								DATA BYTE								STOP (P)			
		1	2	3	4	5	6	7	8	9	10	11	12	13	14	15	16	17	18	19	20	21	22	23	24		25	26	27
		A6	A5	A4	A3	A2	A1	A0	\bar{W}	ACK (A)	R7	R6	R5	R4	R3	R2	R1	R0	ACK (A)	D7	D6	D5	D4	D3	D2	D1	D0	ACK (A)	
REG A		0	1	0	1	A2	A1	A0	0		0	0	0	1	0	0	0	1		D7	D6	D5	D4	D3	D2	D1	D0		
REG B		0	1	0	1	A2	A1	A0	0		0	0	0	1	0	0	1	0		D7	D6	D5	D4	D3	D2	D1	D0		
REG A AND B		0	1	0	1	A2	A1	A0	0		0	0	0	1	0	0	1	1		D7	D6	D5	D4	D3	D2	D1	D0		

Command Byte

Use the command byte to select the destination of the wiper data. See Table 2.

Command Descriptions

REG A: The data byte writes to register A and the wiper of potentiometer A moves to the appropriate position. D[7:0] indicates the position of the wiper. D[7:0] = 00h moves the wiper to the position closest to LA. D[7:0] = FFh moves the wiper closest to HA. D[7:0] is 80h following power-on.

REG B: The data byte writes to register B and the wiper of potentiometer B moves to the appropriate position. D[7:0] indicates the position of the wiper. D[7:0] = 00h moves the wiper to the position closest to LB. D[7:0] = FFh moves the wiper to the position closest to HB. D[7:0] is 80h following power-on.

REG A and B: The data byte writes to registers A and B and the wipers of potentiometers A and B move to the appropriate position. D[7:0] indicates the position of the wiper. D[7:0] = 00h moves the wipers to the position closest to L_. D[7:0] = FFh moves the wipers to the position closest to H_. D[7:0] is 80h following power-on.

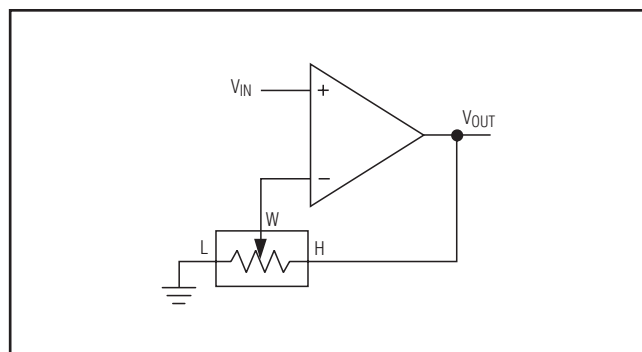

Figure 8. Variable Gain Noninverting Amplifier

Applications Information

Variable Gain Amplifier

Figure 8 shows a potentiometer adjusting the gain of a noninverting amplifier. Figure 9 shows a potentiometer adjusting the gain of an inverting amplifier.

Adjustable Dual Regulator

Figure 10 shows an adjustable dual linear regulator using a dual potentiometer as two variable resistors.

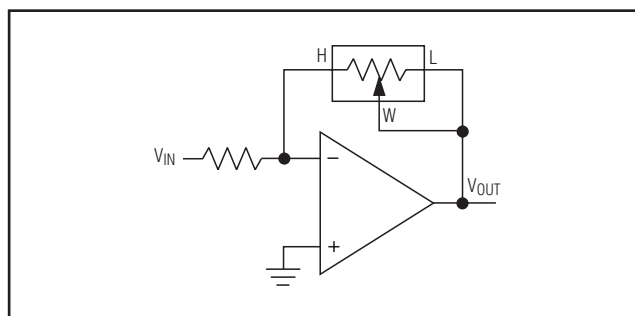

Figure 9. Variable Gain Inverting Amplifier

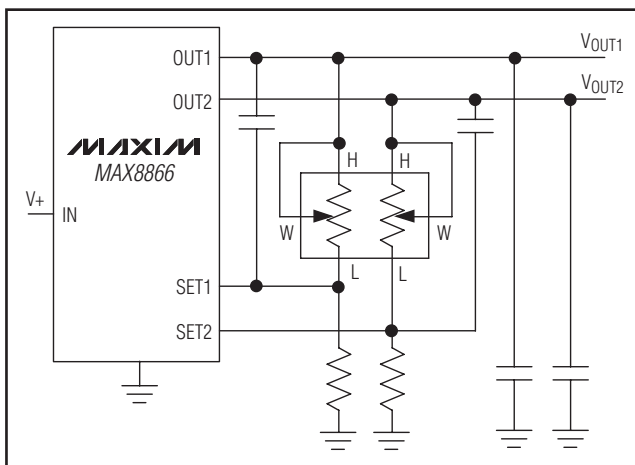

Figure 10. Adjustable Dual Linear Regulator

Dual, 256-Tap, Volatile, Low-Voltage, Linear Taper Digital Potentiometer

Adjustable Voltage Reference

Figure 11 shows an adjustable voltage reference circuit using a potentiometer as a voltage-divider.

Variable Gain Current to Voltage Converter

Figure 12 shows a variable gain current to voltage converter using a potentiometer as a variable resistor.

LCD Bias Control

Figure 13 shows a positive LCD bias control circuit using a potentiometer as a voltage-divider.

Figure 14 shows a positive LCD bias control circuit using a potentiometer as a variable resistor.

Programmable Filter

Figure 15 shows a programmable filter using a dual potentiometer.

Offset Voltage Adjustment Circuit

Figure 16 shows an offset voltage adjustment circuit using a dual potentiometer.

Chip Information

PROCESS: BiCMOS

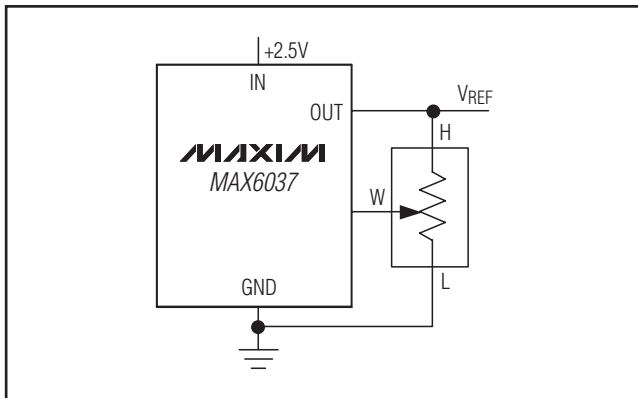

Figure 11. Adjustable Voltage Reference

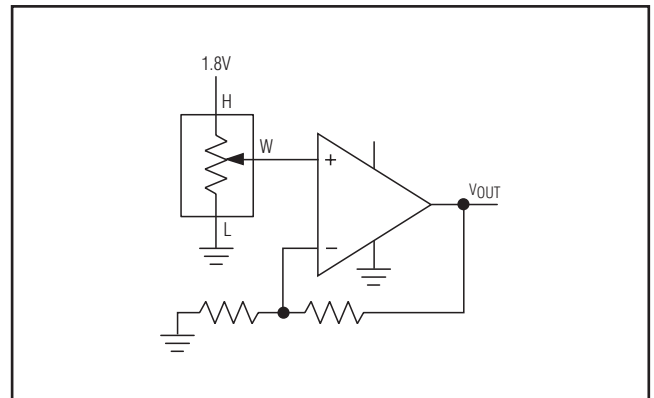

Figure 13. Positive LCD Bias Control Using a Voltage Divider

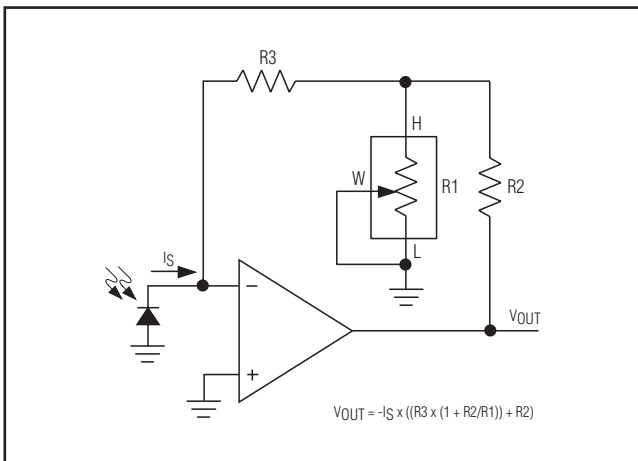

Figure 12. Variable Gain I-to-V Converter

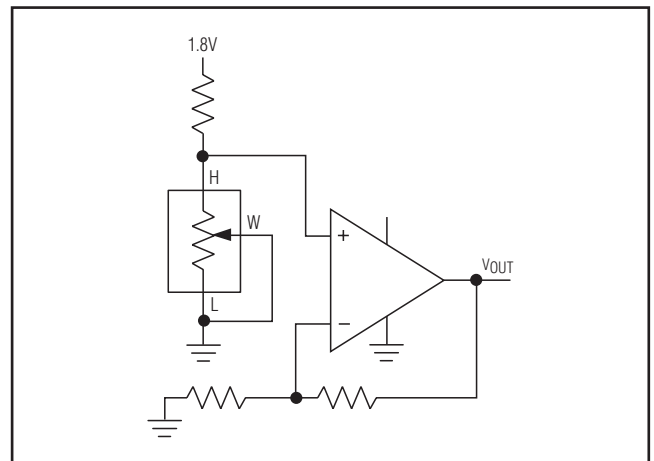

Figure 14. Positive LCD Bias Control Using a Variable Resistor

Dual, 256-Tap, Volatile, Low-Voltage, Linear Taper Digital Potentiometer

MAX5392

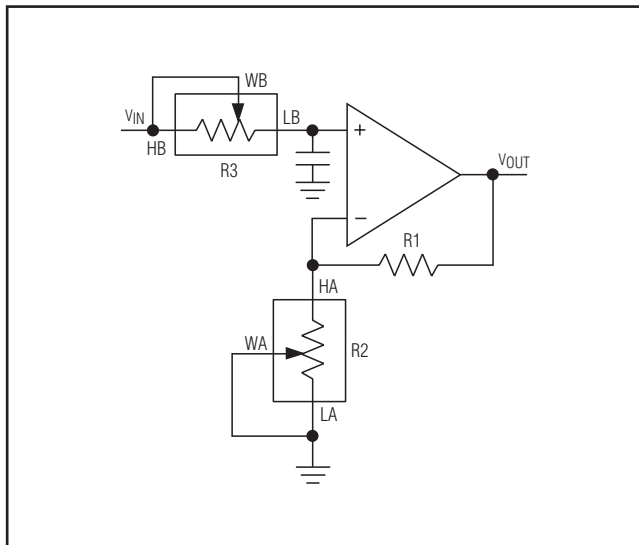

Figure 15. Programmable Filter

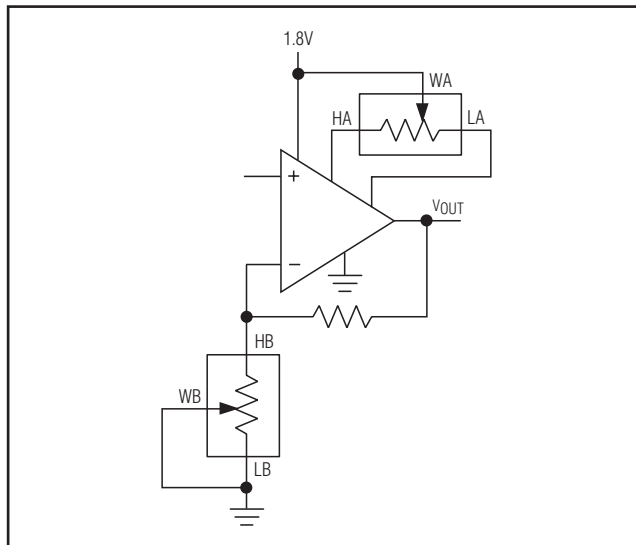

Figure 16. Offset Voltage Adjustment Circuit

Package Information

For the latest package outline information and land patterns, go to www.maxim-ic.com/packages. Note that a "+", "#", or "-" in the package code indicates RoHS status only. Package drawings may show a different suffix character, but the drawing pertains to the package regardless of RoHS status.

PACKAGE TYPE	PACKAGE CODE	OUTLINE NO.	LAND PATTERN NO.
16 TSSOP	U16+2	21-0066	90-0117

Dual, 256-Tap, Volatile, Low-Voltage, Linear Taper Digital Potentiometer

Revision History

REVISION NUMBER	REVISION DATE	DESCRIPTION	PAGES CHANGED
0	1/10	Initial release	—
1	4/10	Added Soldering Temperature in <i>Absolute Maximum Ratings</i> ; corrected code in Conditions of -3dB Bandwidth specification in <i>Electrical Characteristics</i>	2, 3
2	11/10	Changed <i>Electrical Characteristics</i> heading and corrected Figures 9, 12, 14, 15, 16	2, 3, 4, 13, 14, 15

Maxim cannot assume responsibility for use of any circuitry other than circuitry entirely embodied in a Maxim product. No circuit patent licenses are implied. Maxim reserves the right to change the circuitry and specifications without notice at any time.

16 **Maxim Integrated Products, 120 San Gabriel Drive, Sunnyvale, CA 94086 408-737-7600**