

MAXIM

10kΩ Precision-Matched Resistor-Divider in SOT23

MAX5492

General Description

The MAX5492 precision resistor-divider consists of two accurately matched resistors with access to the ends and center of the divider. This device offers excellent resistance matching of 0.035% (A grade), 0.05% (B grade), and 0.1% (C grade). The MAX5492 includes an extremely low-resistance-ratio temperature drift of 1.5ppm/°C (typ) over -55°C to +125°C, and has an end-to-end resistance of 10kΩ. Resistance ratios from 1:1 to 10:1 are available. Five standard ratios are available (see Table 1), and custom ratios are also available upon request. To enhance device and system robustness, the MAX5492 features ±2kV Human Body Model electrostatic discharge (ESD) protection to ensure against real-world ESD events. The MAX5492 is ideal for precision gain-setting applications where tight resistance matching and low temperature drift are necessary.

The MAX5492 is available in a space-saving 5-pin SOT23 package, and is guaranteed over the military -55°C to +125°C temperature range.

Applications

- Industrial Process Control
- Instrumentation
- Precision Gain Setting
- Medical Equipment
- Automatic Test Equipment
- Base Stations

Features

- ◆ Resistance Ratios from 1:1 to 10:1
- ◆ Custom Ratios Available Upon Request
- ◆ Tight Initial Ratio Accuracy
 - 0.035% (MAX5492A)
 - 0.05% (MAX5492B)
 - 0.1% (MAX5492C)
- ◆ Low 1.5ppm/°C (typ) Resistor-Ratio-Drift (1.1:1)
- ◆ Up to 40V Operating Voltage Across Sum of R1 and R2
- ◆ Tiny 5-Pin SOT23 Package

Ordering Information*

PART	TEMP RANGE	PIN-PACKAGE	RATIO ACCURACY (%)
MAX5492_A_-----T	-55°C to +125°C	5 SOT23-5	0.035
MAX5492_B_-----T	-55°C to +125°C	5 SOT23-5	0.05
MAX5492_C_-----T	-55°C to +125°C	5 SOT23-5	0.1

*See the How to Order section for more details.

Block Diagram

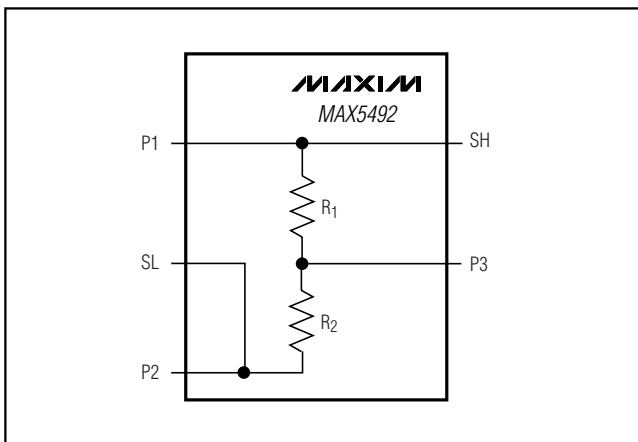

Pin Configuration

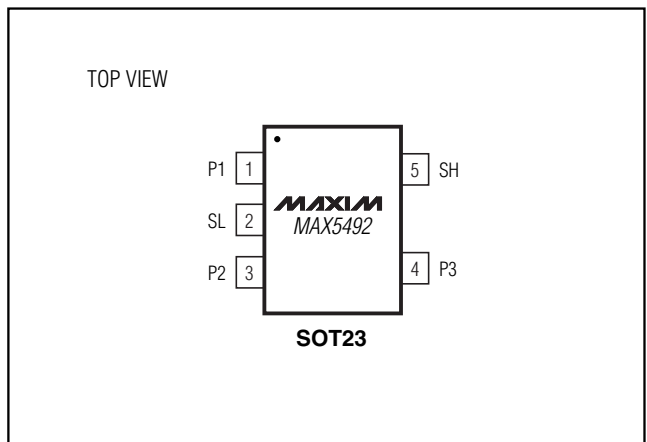

10kΩ Precision-Matched Resistor-Divider in SOT23

ABSOLUTE MAXIMUM RATINGS

Voltage Between P1 and P2	±50V
Continuous Current into Any Pin.....	±4.2mA
Continuous Power Dissipation (T _A = +70°C)	
5-Pin SOT23 (derate 7.1mW/°C above +70°C).....	571.4mW
5-Pin SOT23 (θ _{J-A})	141°C/W

Operating Temperature Range	-55°C to +125°C
Junction Temperature	+150°C
Storage Temperature Range	-65°C to +150°C
Lead Temperature (soldering, 10s)	+300°C

Stresses beyond those listed under "Absolute Maximum Ratings" may cause permanent damage to the device. These are stress ratings only, and functional operation of the device at these or any other conditions beyond those indicated in the operational sections of the specifications is not implied. Exposure to absolute maximum rating conditions for extended periods may affect device reliability.

DC ELECTRICAL CHARACTERISTICS

(T_A = -55°C to +125°C, unless otherwise noted. Typical values are at T_A = +25°C.) (Note 1)

PARAMETER	SYMBOL	CONDITIONS	MIN	TYP	MAX	UNITS
Initial Resistor-Ratio Error (Note 2)		MAX5492_A, T _A = +25°C			±0.035	%
		MAX5492_B, T _A = +25°C			±0.05	
		MAX5492_C, T _A = +25°C			±0.1	
Resistance-Ratio Temperature Coefficient (Note 3)		Ratio 1.1:1		1.5		ppm/°C
		Ratio 1.5:1		3		
		Ratio 3.2:1 ≤ ratio ≤ 10:1		5.5		
Absolute Temperature Coefficient of Resistance	TCR	(Note 4)		35		ppm/°C
Voltage Coefficient of Resistance	VCR	(Note 5)		0.1		ppm/V
End-to-End Resistance (R ₁ + R ₂)			9.25	10	10.75	kΩ
Continuous Working Voltage Between P1 and P2	V _{P1-P2}		-40		+40	V
P1, P2, P3, SL, SH Capacitance				2		pF
Resistance-Ratio Stability		2000 hours at +70°C		±0.03		%
-3dB Bandwidth	f _{3dB}	1.1:1 ratio (Note 6)		30		MHz
Thermal Noise		(Note 7)		45		μV _{RMS}
Current Noise		(Note 8)		<-30		dB
Maximum Power Rating				160		mW

Note 1: The MAX5492 is 100% production tested at T_A = +25°C. Specifications over -55°C to +125°C are guaranteed by design and characterization.

Note 2: Testing conditions: T_A = +25°C, V_{P1-P2} = 10V and 40V.

Note 3: Resistance-ratio temperature coefficient is defined $\left| \frac{\Delta \left(\frac{R_1}{R_2} \right)}{\frac{R_1}{R_2} \times \Delta T} \right|$ and is guaranteed by design, not production tested.

Note 4: Absolute TCR is defined as $\left| \frac{\Delta(R_1 + R_2)}{(R_1 + R_2) \times \Delta T} \right|$ and is tested at 10V and 40V.

Note 5: Resistance-ratio voltage coefficient is defined as $\left| \frac{\Delta \left(\frac{R_1}{R_2} \right)}{\frac{R_1}{R_2} \times \Delta V} \right|$ and is guaranteed by design, not production tested.

10kΩ Precision-Matched Resistor-Divider in SOT23

DC ELECTRICAL CHARACTERISTICS (continued)

(T_A = -55°C to +125°C, unless otherwise noted. Typical values are at T_A = +25°C.) (Note 1)

Note 6: Calculate bandwidth by using $\frac{1}{2\pi RC}$ where C is C_{P3} and $R = \frac{R_1 \times R_2}{R_1 + R_2}$.

Note 7: Calculated according to $\sqrt{\frac{kT}{C}}$ noise.

Note 8: In accordance with the military specification MIL-STD-202G method 308.

Typical Operating Characteristics

(V_{P1-P3} = 10V, T_A = +25°C, unless otherwise noted.)

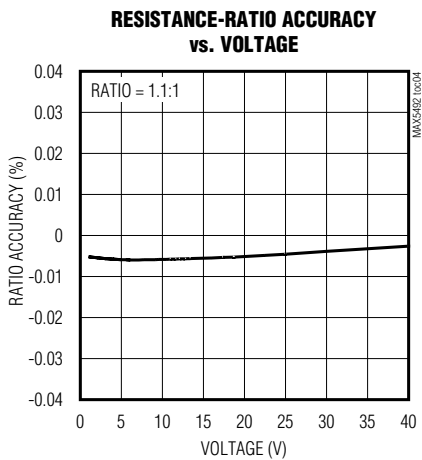
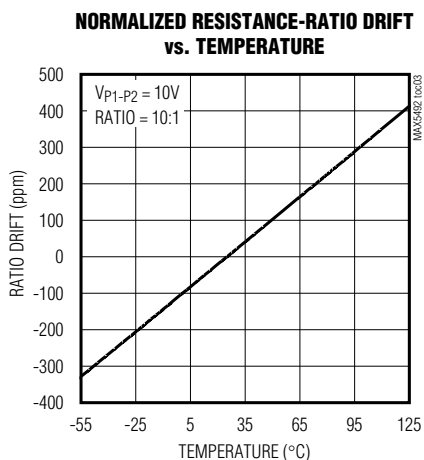
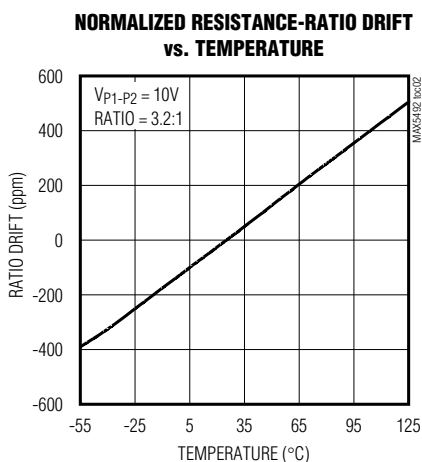
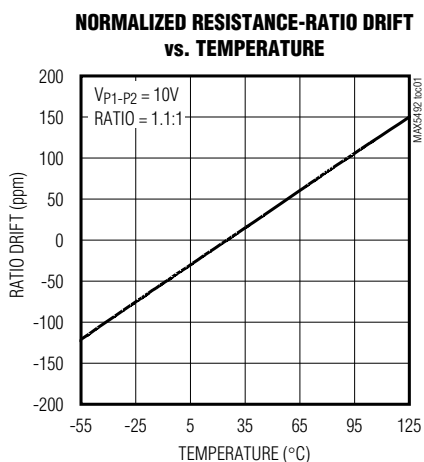

10kΩ Precision-Matched Resistor-Divider in SOT23

Typical Operating Characteristics (continued)

(V_{P1-P3} = 10V, T_A = +25°C, unless otherwise noted.)

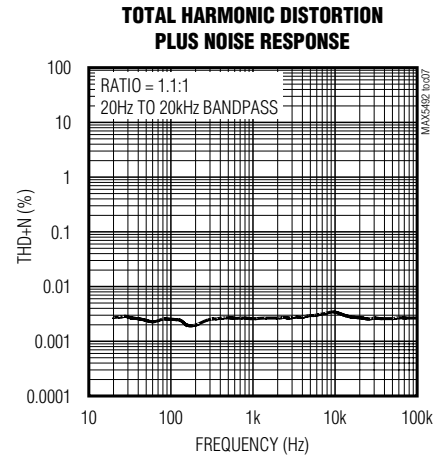
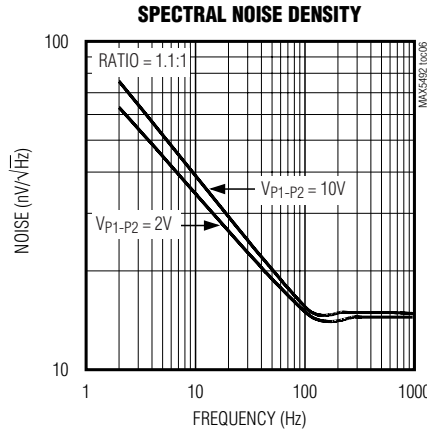
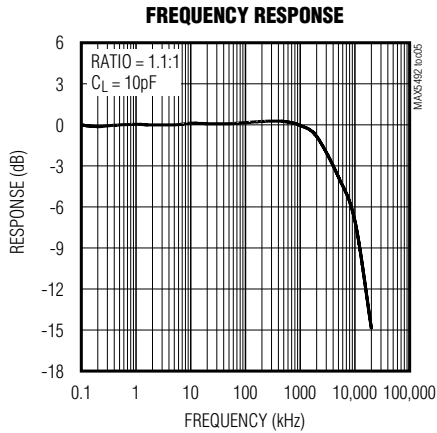

Pin Description

PIN	NAME	FUNCTION
1	P1	R1 Connection Terminal
2	SL	Sense Connection for Low Side of Resistor String. Leave floating or connect in a Kelvin connection configuration.
3	P2	R2 Connection Terminal
4	P3	Set-Point Connection Terminal
5	SH	Sense Connection for High Side of Resistor String. Leave floating or connect in a Kelvin connection configuration.

Detailed Description

The MAX5492 consists of two precision, low-ratio-drift resistors with an end-to-end resistance of 10kΩ (R₁ + R₂). (See Figure 1.) P3 is the set point of the divider. The maximum working voltage of the MAX5492 is 40V. This device offers a wide range of resistance ratios (R₁/R₂) from 1:1 to 10:1 and is ideally suited for precision operational-amplifier gain/attenuation control. The MAX5492 features a ±2kV ESD protection that enhances system robustness. A maximum initial ratio accuracy of 0.035% and a low ratio drift enhance system accuracy.

Applications Information

Kelvin Sensing

Kelvin sensing can improve accuracy in sensitive applications. Apply a voltage or current at P1 and use sense high (SH) and sense low (SL) to monitor the voltage at the upper and lower ends of the resistor string.

10kΩ Precision-Matched Resistor-Divider in SOT23

MAX5492

Typical Applications

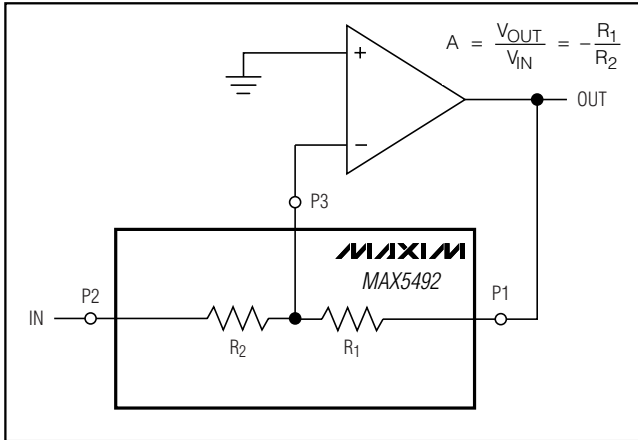

Figure 1. Inverting Amplifier Configuration

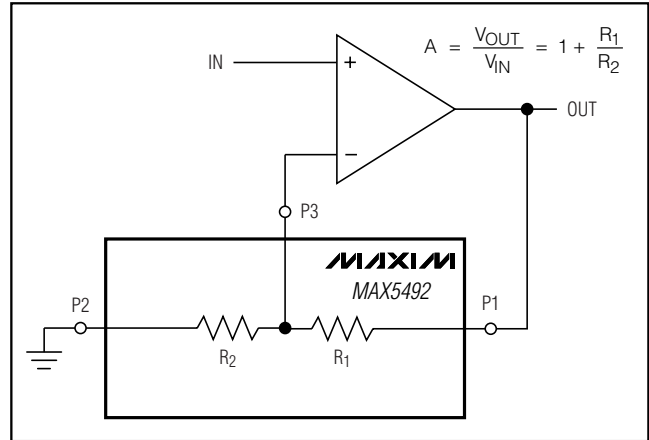

Figure 2. Noninverting Amplifier Configuration

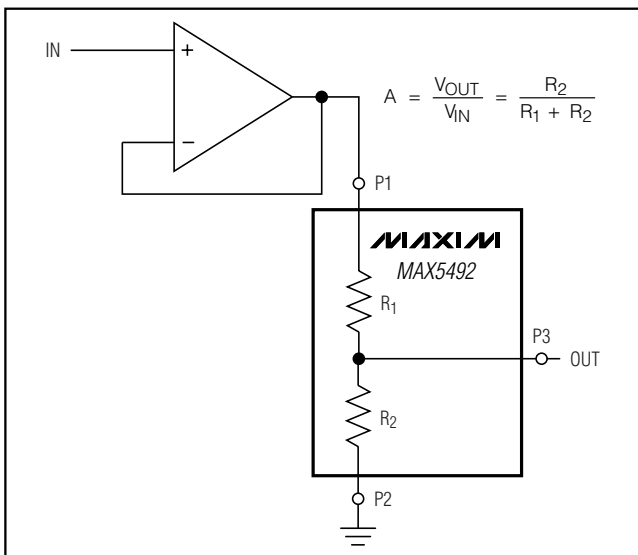

Figure 3. Buffered Attenuator

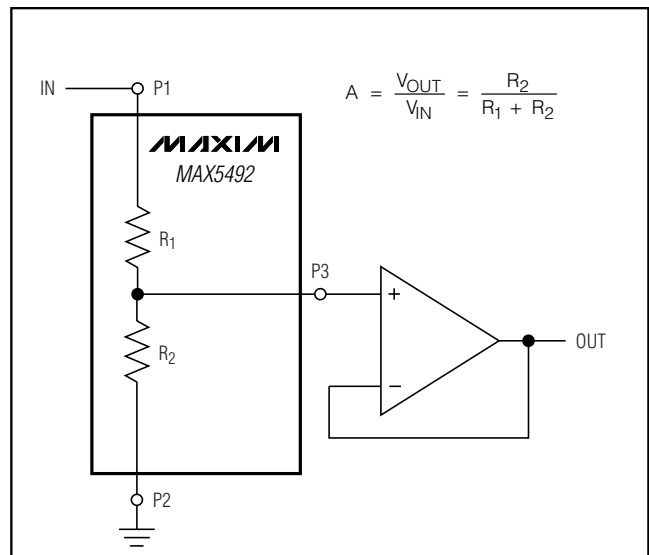

Figure 4. Attenuator with Buffer

Self-Heating and Error

Applying a voltage across terminals P1 and P2 causes the device to heat up due to power dissipation. In high-voltage applications, consider the error in resistance-ratio temperature coefficient caused by self-heating. The worst-case self-heating occurs when the operating voltage attains its maximum value. Approximate the result of power dissipation under this condition as:

$$P_{DISS} = \frac{(V_{MAX})^2}{R} = \frac{(40V)^2}{10k\Omega} = 160mW$$

The thermal resistance from junction to ambient, θ_{J-A} , for a 5-pin SOT23 package is 141°C/W. Calculate the resulting temperature rise as:

$$\Delta T = 160mW \times 141^\circ C/W = 22.5^\circ C$$

If the ratio temperature coefficient is 1.5ppm/°C (typ), the total error introduced by self-heating is:

$$22.5^\circ C \times 1.5ppm/^\circ C = 33.75ppm$$

10kΩ Precision-Matched Resistor-Divider in SOT23

How to Order

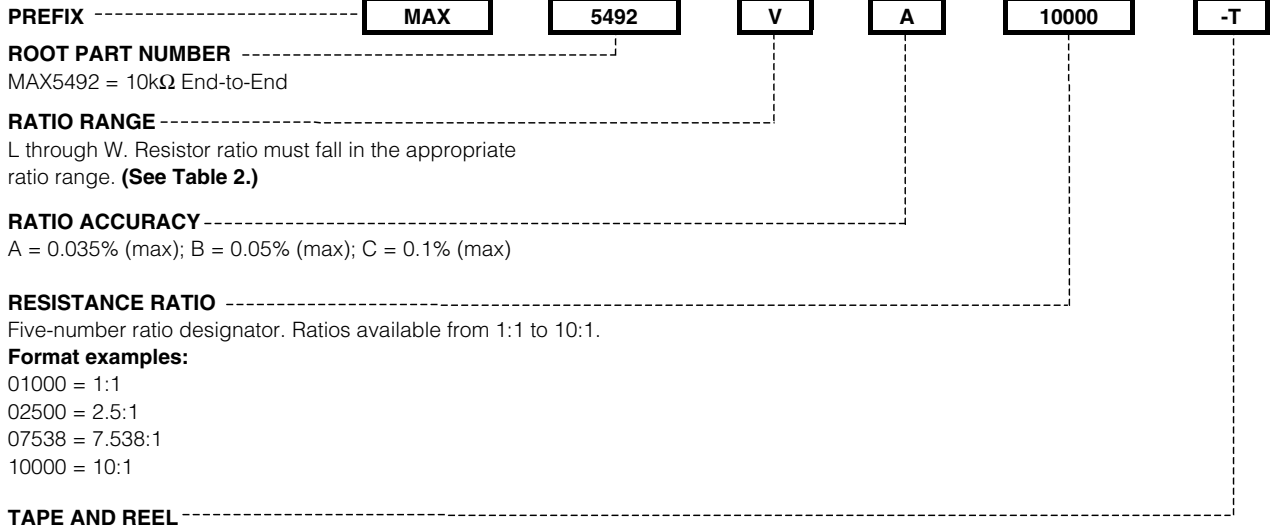

Example Part Numbers

PART NUMBER	RESISTOR-RATIO RANGE	RESISTOR-RATIO ACCURACY (% MAX)	RESISTOR RATIO
MAX5492PA02500-T	2.000 to 2.999	0.035	2.5:1
MAX5492RB03000-T	3.000 to 3.999	0.05	3:1
MAX5492UA07538-T	7.538 to 10.0	0.035	7.538:1

10k Ω Precision-Matched Resistor-Divider in SOT23

MAX5492

Table 1. Standard Ratios*

PART NUMBER	RESISTOR RATIO	RESISTOR-RATIO SUFFIX	RESISTOR-RATIO ACCURACY (% MAX)	TOP MARK
MAX5492RA01100-T	1.1:1	01100	0.035	AERA
MAX5492RB01100-T	1.1:1	01100	0.05	AERC
MAX5492RC01100-T	1.1:1	01100	0.1	AERE
MAX5492PA01500-T	1.5:1	01500	0.035	AEQU
MAX5492PB01500-T	1.5:1	01500	0.05	AEQW
MAX5492PC01500-T	1.5:1	01500	0.1	AEQY
MAX5492PA03200-T	3.2:1	03200	0.035	AEVE
MAX5492PB03200-T	3.2:1	03200	0.05	AEVF
MAX5492PC03200-T	3.2:1	03200	0.1	AEVG
MAX5492LA07538-T	7.538:1	07538	0.035	AEQB
MAX5492LB07538-T	7.538:1	07538	0.05	AEQD
MAX5492LC07538-T	7.538:1	07538	0.1	AEQF
MAX5492LA10000-T	10:1	10000	0.035	AEQC
MAX5492LB10000-T	10:1	10000	0.05	AEQE
MAX5492LC10000-T	10:1	10000	0.1	AEQG

*Standard ratios are available for ordering in any quantity. Nonstandard ratios are also available for values from 1:1 to 10:1. A minimum order quantity of 10,000 units is required for nonstandard ratios. Contact factory for more information.

Table 2. Ratio Ranges

LETTER SUFFIX	RESISTOR-RATIO RANGE
R	1.0 to 1.399
P	1.4 to 1.999
N	2.0 to 2.999
M	3.0 to 7.537
L	7.538 to 10

Chip Information

TRANSISTOR COUNT: 0
PROCESS: BiCMOS

10kΩ Precision-Matched Resistor-Divider in SOT23

Package Information

(The package drawing(s) in this data sheet may not reflect the most current specifications. For the latest package outline information, go to www.maxim-ic.com/packages.)

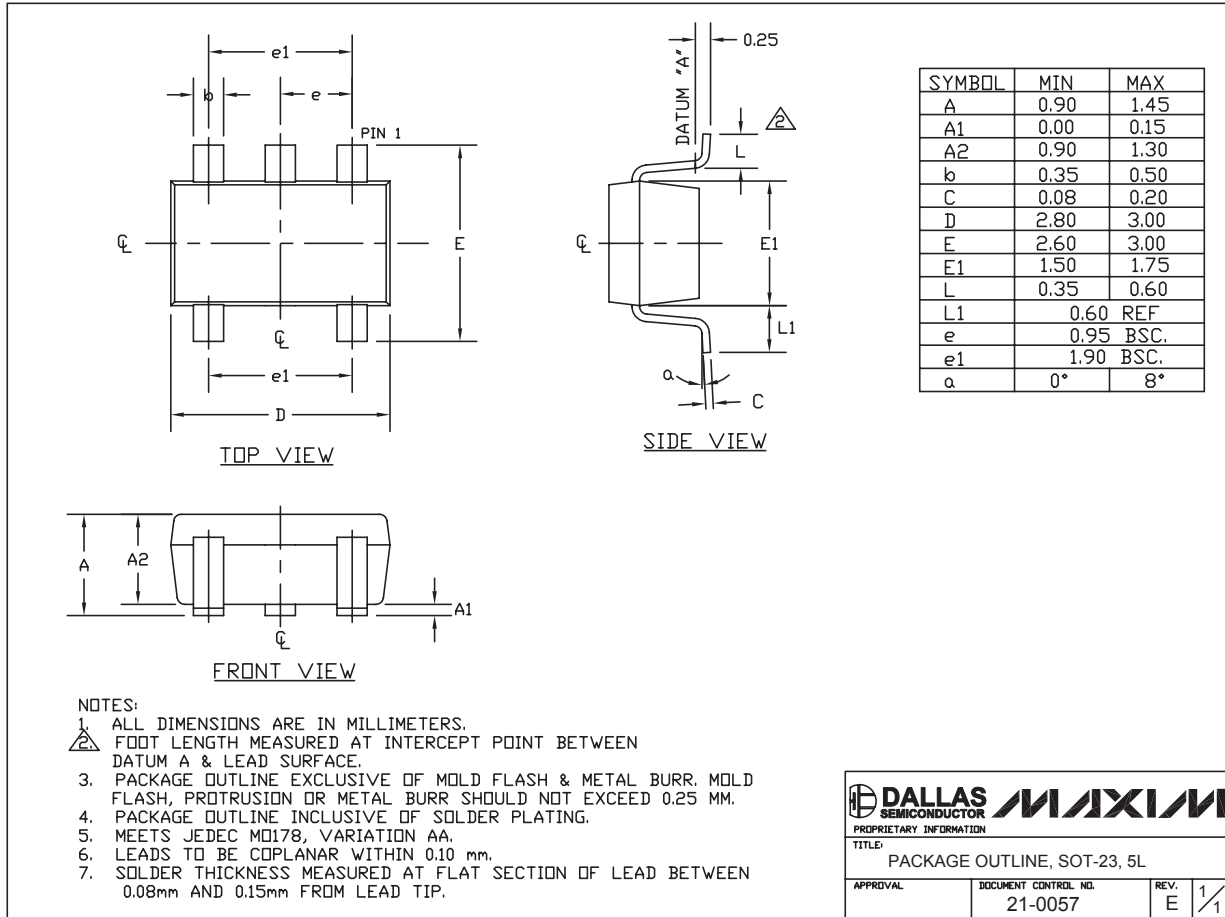

SOT-23 5L .EPS

DALLAS SEMICONDUCTOR **MAXIM**

PROPRIETARY INFORMATION

TITLE: PACKAGE OUTLINE, SOT-23, 5L

APPROVAL	DOCUMENT CONTROL NO. 21-0057	REV. E	1/1
----------	---------------------------------	-----------	-----

Maxim cannot assume responsibility for use of any circuitry other than circuitry entirely embodied in a Maxim product. No circuit patent licenses are implied. Maxim reserves the right to change the circuitry and specifications without notice at any time.

8 Maxim Integrated Products, 120 San Gabriel Drive, Sunnyvale, CA 94086 408-737-7600