

X9110

Dual Supply/Low Power/1024-Tap/SPI Bus, Single Digitally-Controlled (XDCP™) Potentiometer

FN8158
Rev 5.00
October 28, 2016

The [X9110](#) integrates a Single Digitally Controlled Potentiometer (XDCP) on a monolithic CMOS integrated circuit.

The digital controlled potentiometer is implemented using 1023 resistive elements in a series array. Between each element are tap points connected to the wiper terminal through switches. The position of the wiper on the array is controlled by the user through the SPI bus interface. The potentiometer has associated with it a volatile Wiper Counter Register (WCR) and four nonvolatile data registers that can be directly written to, and read by, the user. The contents of the WCR controls the position of the wiper on the resistor array through the switches. Power-up recalls the contents of the default data register (DRO) to the WCR.

The XDCP can be used as a three-terminal potentiometer or as a two terminal variable resistor in a wide variety of applications including control, parameter adjustments, and signal processing.

Related Literature

- For a full list of related documents, visit our website - [X9110](#) product page

Features

- 1024 resistor taps – 10-bit resolution
- SPI serial interface for write, read, and transfer operations of the potentiometer
- Wiper resistance, 40Ω typical at 5V
- Four nonvolatile data registers
- Nonvolatile storage of multiple wiper positions
- Power-on recall, loads saved wiper position on power-up
- Standby current <5μA maximum
- System V_{CC}: 2.7V to 5.5V operation
- Analog V₊/V₋: -5V to +5V
- 100kΩ end-to-end resistance
- 100 year data retention
- Endurance: 100,000 data changes per bit per register
- 14 Ld TSSOP
- Dual supply version of the X9111
- Low power CMOS
- Pb-free (RoHS compliant)

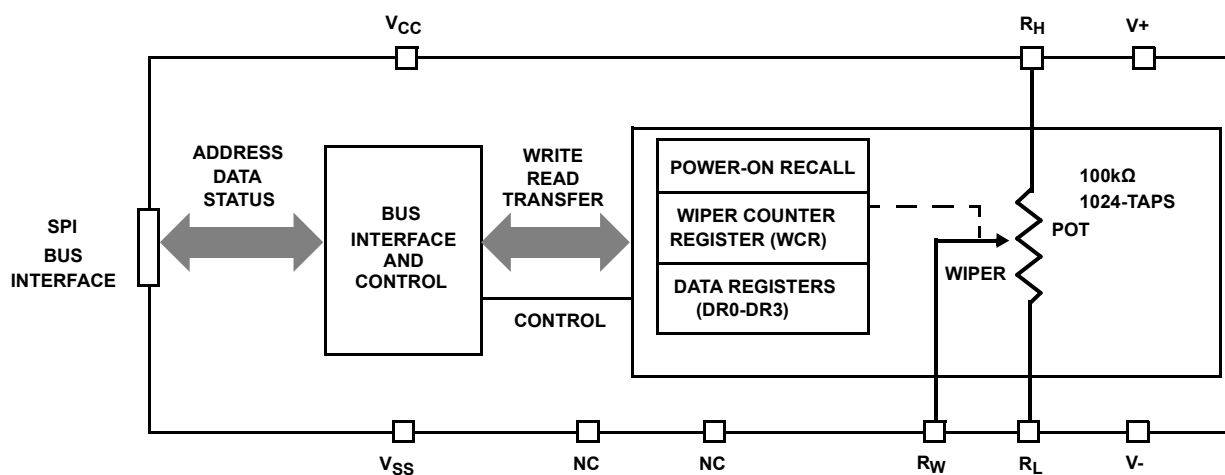

FIGURE 1. FUNCTIONAL DIAGRAM

Applications

Circuit Level Applications

- Vary the gain of a voltage amplifier
- Provide programmable DC reference voltages for comparators and detectors
- Control the volume in audio circuits
- Trim out the offset voltage error in a voltage amplifier circuit
- Set the output voltage of a voltage regulator
- Trim the resistance in Wheatstone bridge circuits
- Control the gain, characteristic frequency and Q-factor in filter circuits
- Set the scale factor and zero point in sensor signal conditioning circuits
- Vary the frequency and duty cycle of timer ICs
- Vary the DC biasing of a pin diode attenuator in RF circuits
- Provide a control variable (I, V, or R) in feedback circuits

System Level Applications

- Adjust the contrast in LCD displays
- Control the power level of LED transmitters in communication systems
- Set and regulate the DC biasing point in an RF power amplifier in wireless systems
- Control the gain in audio and home entertainment systems
- Provide the variable DC bias for tuners in RF wireless systems
- Set the operating points in temperature control systems
- Control the operating point for sensors in industrial systems
- Trim offset and gain errors in artificial intelligent systems

Ordering Information

PART NUMBER (Notes 2, 3)	PART MARKING	V _{CC} LIMITS (V)	POTENTIOMETER RANGE (kΩ)	TEMP RANGE (°C)	PACKAGE (RoHS COMPLIANT)	PKG. DWG. #
X9110TV14Z (Note 1)	X9110 TVZ	5 ±10	100	0 to +70	14 Ld TSSOP	M14.173
X9110TV14IZ	X9110 TVZI			-40 to +85	14 Ld TSSOP	M14.173
X9110TV14Z-2.7	X9110 TVZF	2.7 to 5.5		0 to +70	14 Ld TSSOP	M14.173
X9110TV14IZ-2.7 (Note 1)	X9110 TVZG			-40 to +85	14 Ld TSSOP	M14.173

NOTES:

1. Add "T1" suffix for 2.5k unit tape and reel option.
2. These Intersil Pb-free plastic packaged products employ special Pb-free material sets, molding compounds/die attach materials, and 100% matte tin plate plus anneal (e3 termination finish, which is RoHS compliant and compatible with both SnPb and Pb-free soldering operations). Intersil Pb-free products are MSL classified at Pb-free peak reflow temperatures that meet or exceed the Pb-free requirements of IPC/JEDEC J STD-020.
3. For Moisture Sensitivity Level (MSL), see product information page for [X9110](#). For more information on MSL, see tech brief [TB363](#).

Detailed Functional Diagram

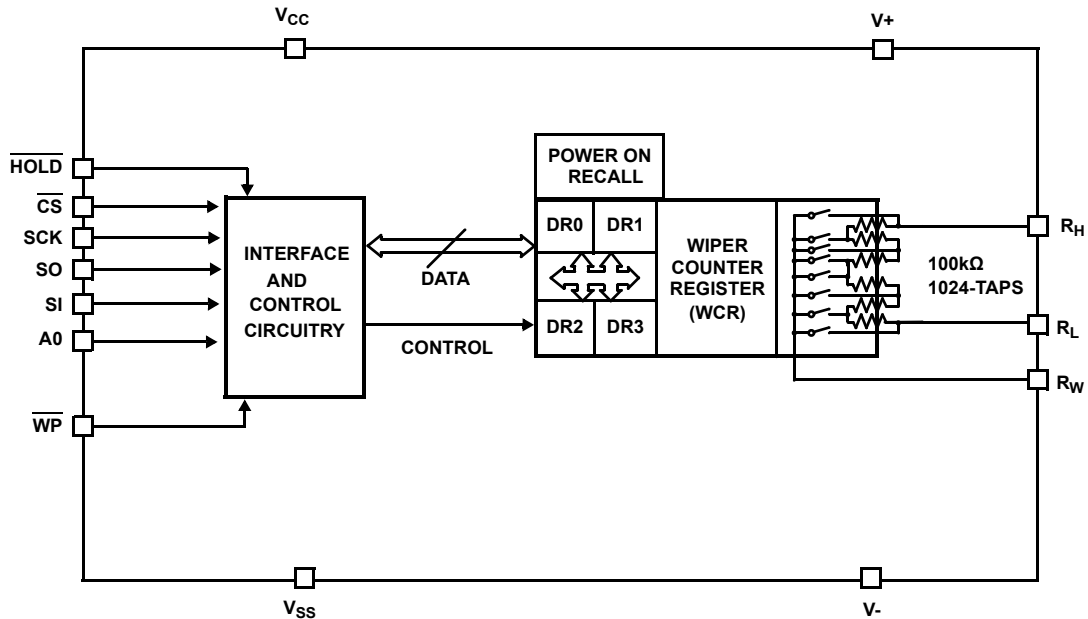
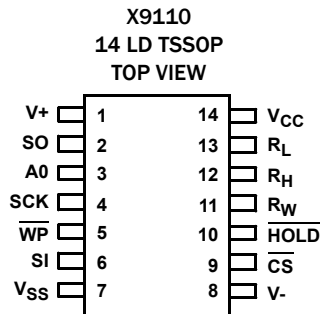

FIGURE 2. DETAILED FUNCTIONAL DIAGRAM

Pin Configuration



Pin Descriptions

PIN (TSSOP)	SYMBOL	FUNCTION
1	V+	Analog Supply Voltage
2	SO	Serial Data Output
3	A0	Device Address
4	SCK	Serial Clock
5	WP	Hardware Write Protect
6	SI	Serial Data Input
7	V _{SS}	System Ground
8	V-	Analog Supply Voltage
9	CS	Chip Select
10	HOLD	Device Select. Pause the Serial Bus

Pin Descriptions (Continued)

PIN (TSSOP)	SYMBOL	FUNCTION
11	R _W	Wiper Terminal of the Potentiometer
12	R _H	High Terminal of the Potentiometer
13	R _L	Low Terminal of the Potentiometer
14	V _{CC}	System Supply Voltage

Bus Interface Pins

SERIAL OUTPUT (SO)

SO is a serial data output pin. During a read cycle, data is shifted out on this pin. Data is clocked out on the falling edge of the serial clock.

SERIAL INPUT (SI)

SI is the serial data input pin. All opcodes, byte addresses and data to be written to the potentiometer pot registers are input on this pin. Data is latched by the rising edge of the serial clock.

SERIAL CLOCK (SCK)

The SCK input is used to clock data into and out of the X9110.

HOLD (HOLD)

HOLD is used in conjunction with the CS pin to select the device. Once the part is selected and a serial sequence is underway, HOLD may be used to pause the serial communication with the controller without resetting the serial sequence. To pause, HOLD must be brought LOW while SCK is LOW. To resume communication, HOLD is brought HIGH, again while SCK is LOW.

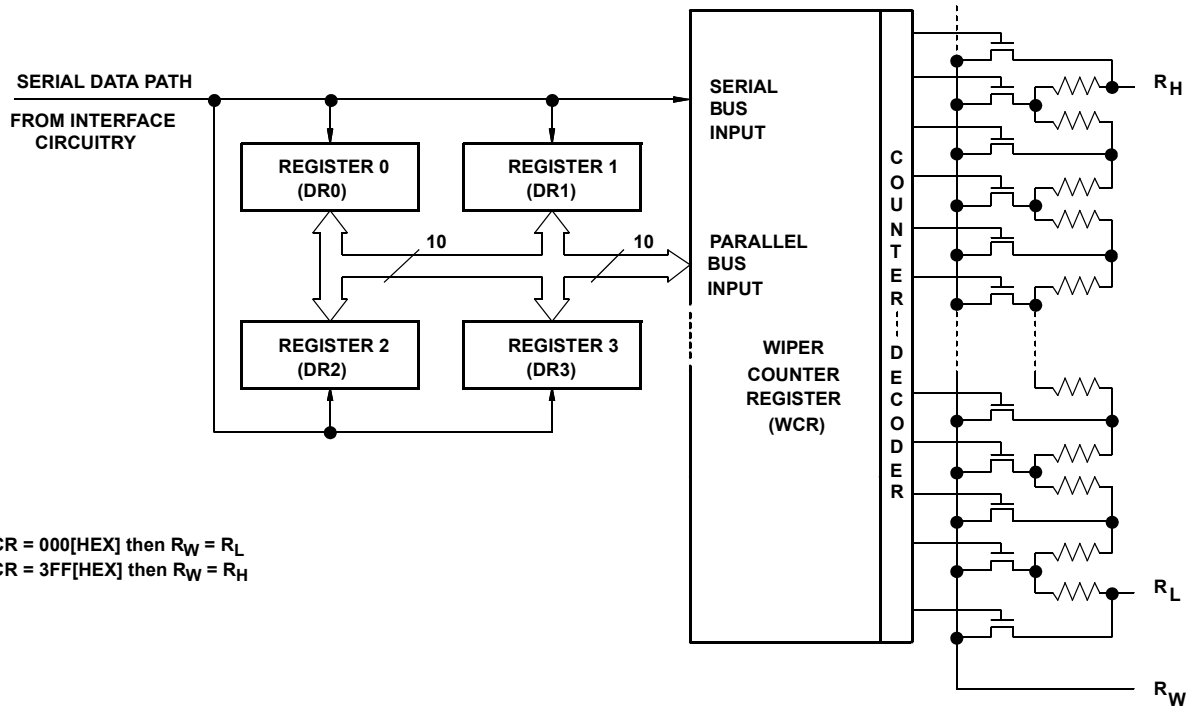

FIGURE 3. DETAILED POTENTIOMETER BLOCK DIAGRAM

If the pause feature is not used, $\overline{\text{HOLD}}$ should be held HIGH at all times.

DEVICE ADDRESS (A0)

The address input is used to set the 8-bit slave address. A match in the slave address serial data stream A0 must be made with the address input (A0) in order to initiate communication with the X9110.

CHIP SELECT ($\overline{\text{CS}}$)

When $\overline{\text{CS}}$ is HIGH, the X9110 is deselected and the SO pin is at high impedance, and (unless an internal write cycle is underway) the device will be in the standby state. $\overline{\text{CS}}$ LOW enables the X9110, placing it in the active power mode. It should be noted that after a power-up, a HIGH to LOW transition on $\overline{\text{CS}}$ is required prior to the start of any operation.

HARDWARE WRITE PROTECT INPUT ($\overline{\text{WP}}$)

The $\overline{\text{WP}}$ pin when LOW prevents nonvolatile writes to the Data Registers.

Potentiometer Pins

R_H , R_L

The R_H and R_L pins are equivalent to the terminal connections on a mechanical potentiometer.

R_W

The wiper pin are equivalent to the wiper terminal of a mechanical potentiometer.

Bias Supply Pins

SYSTEM SUPPLY VOLTAGE (V_{CC}) AND SUPPLY GROUND (V_{SS})

The V_{CC} pin is the system supply voltage. The V_{SS} pin is the system ground.

ANALOG SUPPLY VOLTAGES ($V+$ AND $V-$)

These supplies are the analog voltage supplies for the potentiometer. The $V+$ supply is tied to the wiper switches while the $V-$ supply is used to bias the switches and the internal P+ substrate of the integrated circuit. Both of these supplies set the voltage limits of the potentiometer.

Principles of Operation

Device Description

SERIAL INTERFACE

The X9110 supports the SPI interface hardware conventions. The device is accessed via the SI input with data clocked-in on the rising SCK. $\overline{\text{CS}}$ must be LOW and the $\overline{\text{HOLD}}$ and $\overline{\text{WP}}$ pins must be HIGH during the entire operation.

The SO and SI pins can be connected together, since they have three state outputs. This can help to reduce system pin count.

ARRAY DESCRIPTION

The X9110 is comprised of a resistor array (Figure 3). The array contains the equivalent of 1023 discrete resistive segments that are connected in series. The physical ends of each array are equivalent to the fixed terminals of a mechanical potentiometer (R_H and R_L inputs).

At both ends of each array and between each resistor segment is a CMOS switch connected to the wiper (R_W) output. Within the individual array only one switch may be turned on at a time.

These switches are controlled by a Wiper Counter Register (WCR). The 10-bits of the WCR (WCR[9:0]) are decoded to select, and enable, one of 1024 switches.

WIPER COUNTER REGISTER (WCR)

The X9110 contains a Wiper Counter Register (see Table 1) for the XDCP potentiometer. The WCR is equivalent to a serial-in, parallel-out register/counter with its outputs decoded to select one of 1024 switches along its resistor array. The content of the WCR can be altered in one of three ways: (1) it may be written directly by the host via the write Wiper Counter Register instruction (serial load); (2) it may be written indirectly by transferring the content of one of four associated Data Registers via the XFR Data Register; (3) it is loaded with the content of its data register zero (DR0) upon power-up.

The Wiper Counter Register is a volatile register; that is, its content is lost when the X9110 is powered-down. Although the register is automatically loaded with the value in DR0 upon power-up, this may be different from the value present at power-down. Power-up guidelines are recommended to ensure proper loadings of the DR0 value into the WCR.

DATA REGISTERS (DR)

The potentiometer has four 10-bit nonvolatile Data Registers. These can be read or written directly by the host. Data can also be transferred between any of the four Data Registers and the Wiper Counter Register. All operations changing data in one of the Data Registers is a nonvolatile operation and will take a maximum of 10ms.

If the application does not require storage of multiple settings for the potentiometer, the Data Registers can be used as regular memory locations for system parameters or user preference data.

DR[9:0] is used to store one of the 1024 wiper position (0~1023) (see Table 2).

STATUS REGISTER (SR)

This 1-bit status register is used to store the system status (see Table 3).

WIP: Write In Progress status bit, read only.

- When WIP = 1, indicates that high-voltage write cycle is in progress.
- When WIP = 0, indicates that no high-voltage write cycle is in progress.

TABLE 1. WIPER CONTROL REGISTER, WCR (10-BIT), WCR9–WCR0: Used to store the current wiper position (Volatile, V)

WCR9	WCR8	WCR7	WCR6	WCR5	WCR4	WCR3	WCR2	WCR1	WCR0
V	V	V	V	V	V	V	V	V	V
(MSB)									(LSB)

TABLE 2. DATA REGISTER, DR (10-BIT), BIT 9–BIT 0: Used to store wiper positions or data (Nonvolatile, NV)

BIT 9	BIT 8	BIT 7	BIT 6	BIT 5	BIT 4	BIT 3	BIT 2	BIT 1	BIT 0
NV	NV	NV	NV	NV	NV	NV	NV	NV	NV
(MSB)									(LSB)

TABLE 3. STATUS REGISTER, SR (1-BIT)

WIP
(LSB)

TABLE 4. IDENTIFICATION BYTE FORMAT

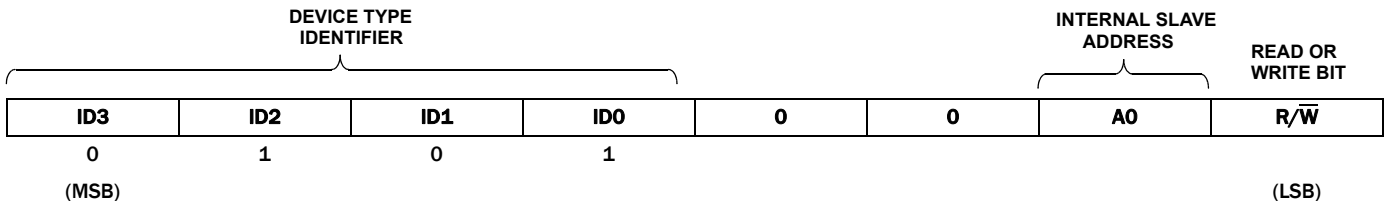
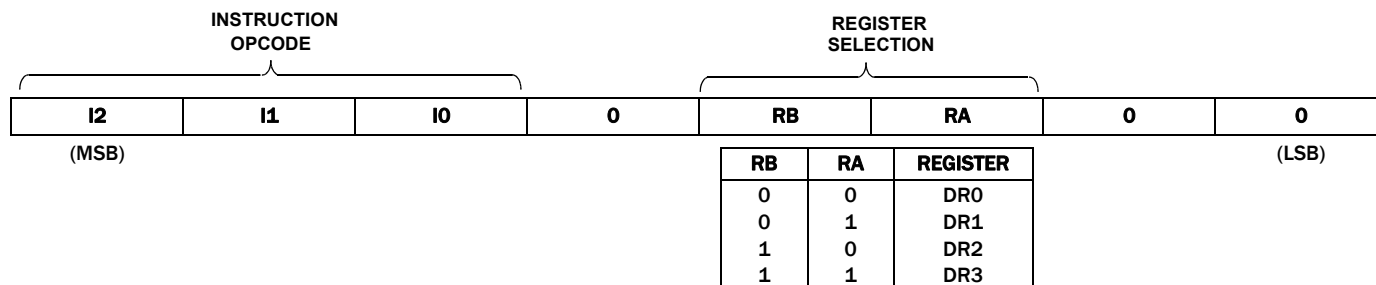

TABLE 5. INSTRUCTION BYTE FORMAT



Device Instructions

Identification Byte (ID and A)

The first byte sent to the X9110 from the host, following a \overline{CS} going HIGH to LOW, is called the Identification byte. The most significant four bits of the slave address are a device type identifier. The ID[3:0] bits is the device ID for the X9110; this is fixed as 0101[B] (refer to [Table 4](#)).

The A0 bit in the ID byte is the internal slave address. The physical device address is defined by the state of the A0 input pin. The slave address is externally specified by the user. The X9110 compares the serial data stream with the address input state; a successful compare of the address bit is required for the X9110 to successfully continue the command sequence. Only the device whose slave address matches the incoming device address sent by the master executes the instruction. The A0 input can be actively driven by CMOS input signals or tied to V_{CC} or V_{SS} . The R/W bit is used to set the device to either read or write mode.

Instruction Byte and Register Selection

The next byte sent to the X9110 contains the instruction and register pointer information. The three most significant bits are used provide the instruction opcode (I[2:0]). The RB and RA bits point to one of the four registers. The format is shown in [Table 5](#).

Five of the seven instructions are four bytes in length. These instructions are:

1. **Read Wiper Counter Register** – This register reads the current wiper position of the selected pot.
2. **Write Wiper Counter Register** – This register changes current wiper position of the selected pot.
3. **Read Data Register** – This register reads the contents of the selected data register.
4. **Write Data Register** – This register writes a new value to the selected data register.
5. **Read Status** – This command returns the contents of the WIP bit, which indicates if the internal write cycle is in progress.

The basic sequence of the four byte instructions is illustrated in [Figure 5 on page 7](#). These four-byte instructions exchange data between the WCR and one of the Data Registers. A transfer from a Data Register to a WCR is essentially a write to a static RAM, with the static RAM controlling the wiper position. The response of the wiper to this action will be delayed by t_{WRL} . A transfer from the WCR (current wiper position), to a Data Register is a write to nonvolatile memory and takes a minimum of t_{WR} to complete. The transfer can occur between the potentiometer and

one of its associated registers. The Read Status Register instruction is the only unique format (see [Figure 6 on page 7](#)).

Two instructions require a two-byte sequence to complete (see [Figure 4 on page 7](#)). These instructions transfer data between the host and the X9110; either between the host and one of the Data Registers or directly between the host and the Wiper Counter Register. These instructions are:

1. **XFR Data Register to Wiper Counter Register** – This register transfers the content of one specified Data Register to the associated Wiper Counter Register.
2. **XFR Wiper Counter Register to Data Register** – This register transfers the content of the specified Wiper Counter Register to the specified associated Data Register.

See [“Instruction Format” on page 8](#) for more details.

Write in Process (WIP bit)

The content of the Data Registers are saved to nonvolatile memory when the \overline{CS} pin goes from LOW to HIGH after a complete write sequence is received by the device. The progress of this internal write operation can be monitored by a Write In Process (WIP) bit. The WIP bit is read with a Read Status command (see [Figure 6](#)).

Power-Up and Power-Down Requirements

At all times, the $V+$ voltage must be greater than or equal to the voltage at R_H or R_L , and the voltage at R_H or R_L must be greater than or equal to the voltage at $V-$. During power-up and power-down, V_{CC} , $V+$, and $V-$ must reach their final values within 1ms of each other.

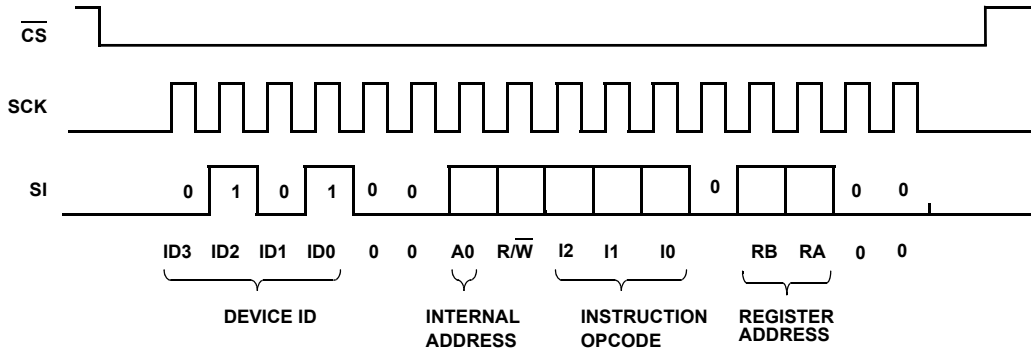

FIGURE 4. TWO-BYTE INSTRUCTION SEQUENCE

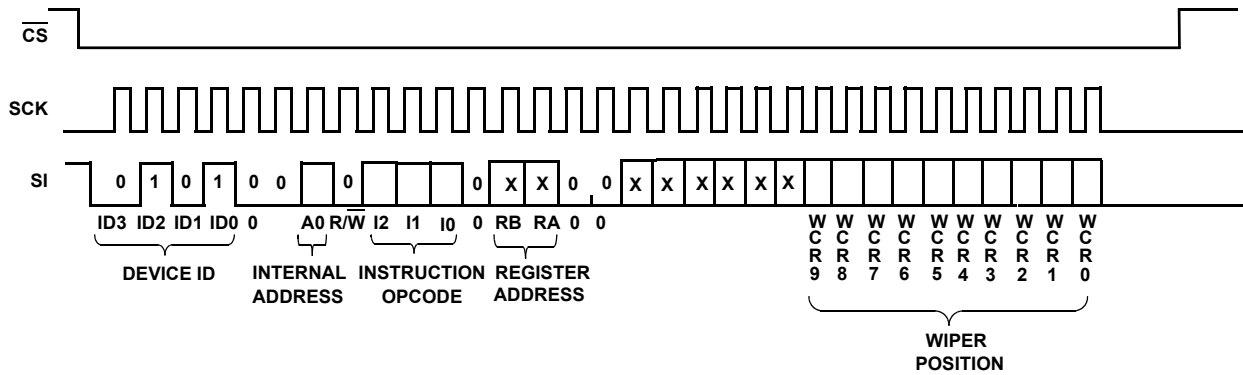

FIGURE 5. FOUR-BYTE INSTRUCTION SEQUENCE (WRITE OR READ FOR WCR OR DATA REGISTERS)

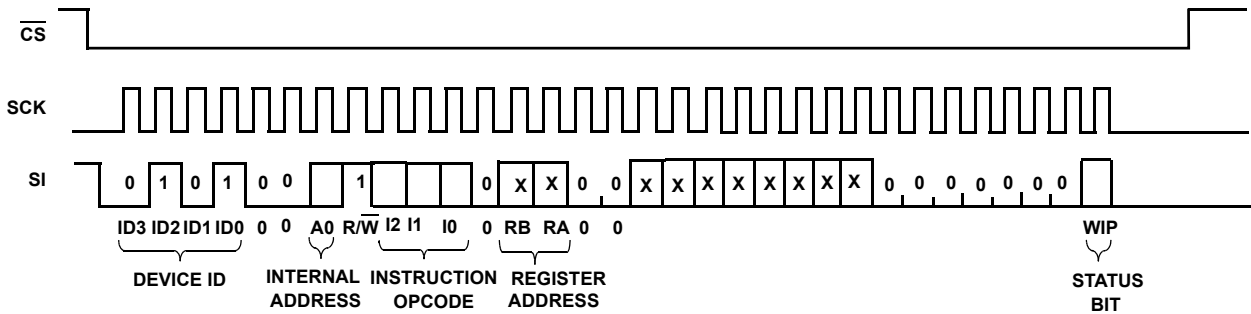

FIGURE 6. FOUR-BYTE INSTRUCTION SEQUENCE (READ STATUS REGISTERS)

TABLE 6. INSTRUCTION SET

INSTRUCTION	INSTRUCTION SET									OPERATION
	R/ \overline{W}	I ₂	I ₁	I ₀	0	RB	RA	0	0	
Read Wiper Counter Register	1	1	0	0	0	0	0	0	0	Read the contents of the Wiper Counter Register
Write Wiper Counter Register	0	1	0	1	0	0	0	0	0	Write new value to the Wiper Counter Register
Read Data Register	1	1	0	1	0	1/0	1/0	0	0	Read the contents of the Data Register pointed to RB-RA
Write Data Register	0	1	1	0	0	1/0	1/0	0	0	Write new value to the Data Register pointed to RB-RA
XFR Data Register to Wiper Counter Register	1	1	1	0	0	1/0	1/0	0	0	Transfer the contents of the Data Register pointed to by RB-RA to the Wiper Counter Register
XFR Wiper Counter Register to Data Register	0	1	1	1	0	1/0	1/0	0	0	Transfer the contents of the Wiper Counter Register to the Data Register pointed to by RB-RA
Read Status (WIP bit)	1	0	1	0	0	0	0	0	1	Read the status of the internal write cycle, by checking the WIP bit (read status register).

NOTE: 1/0 = data is one or zero

Instruction Format

Read Wiper Counter Register (WCR)

\overline{CS} Falling Edge	Device Type Identifier		Device Addresses				R/ \overline{W} = 1	Instruction Opcode				Register Addresses				Wiper Position (Sent by X9110 on SO)								\overline{CS} Rising Edge								
	0	1	0	1	0	0		A0	1	0	0	0	0	0	0	0	X	X	X	X	X	X	W		W	W	W	W	W	W	W	W
																						C	C	C	C	C	C	C	C	C	C	C
																						R	R	R	R	R	R	R	R	R	R	R
																						9	8	7	6	5	4	3	2	1	0	

Write Wiper Counter Register (WCR)

\overline{CS} Falling Edge	Device Type Identifier		Device Addresses				R/ \overline{W} = 0	Instruction Opcode				Register Addresses				Wiper Position (Sent by Master on SI)								\overline{CS} Rising Edge								
	0	1	0	1	0	0		A0	1	0	1	0	0	0	0	0	X	X	X	X	X	X	W		W	W	W	W	W	W	W	W
																						C	C	C	C	C	C	C	C	C	C	C
																						R	R	R	R	R	R	R	R	R	R	R
																						9	8	7	6	5	4	3	2	1	0	

Read Data Register (DR)

\overline{CS} Falling Edge	Device Type Identifier		Device Addresses				R/ \overline{W} = 1	Instruction Opcode				Register Addresses				Wiper Position (Sent by X9110 on SO)								\overline{CS} Rising Edge								
	0	1	0	1	0	0		A0	1	0	1	0	RB	RA	0	0	X	X	X	X	X	X	W		W	W	W	W	W	W	W	W
																						C	C	C	C	C	C	C	C	C	C	C
																						R	R	R	R	R	R	R	R	R	R	R
																						9	8	7	6	5	4	3	2	1	0	

Absolute Maximum Ratings

Voltage on SCK any Address Input with Respect to V_{SS}	-1V to +7V
Voltage on V+ (referenced to V_{SS}) (Note 11)	10V
Voltage on V- (referenced to V_{SS}) (Note 11)	-10V
(V+) - (V-)	12V
Any Voltage on R_H/R_L	V+
Any Voltage on R_L/R_H	V-
I_W (10s)	±6mA

Thermal Information

Thermal Resistance (Typical, Note 7)	θ_{JA} (°C/W)
14 Lead TSSOP	90
Temperature Under Bias	-65°C to +135°C
Storage Temperature	-65°C to +150°C
Pb-Free Reflow Profile	see TB493

Recommended Operating Conditions

Temperature Range	
Commercial	0°C to +70°C
Industrial	-40°C to +85°C
Supply Voltage (V_{CC}) Limits (Note 11)	
X91105V ±10%
X9110-2.7	2.7V to 5.5V

CAUTION: Do not operate at or near the maximum ratings listed for extended periods of time. Exposure to such conditions may adversely impact product reliability and result in failures not covered by warranty.

NOTE:

- θ_{JA} is measured with the component mounted on a high effective thermal conductivity test board in free air. See Tech Brief [TB379](#) for details.

Analog Specifications

Over recommended industrial (2.7V) operation conditions, unless otherwise stated.

SYMBOL	PARAMETER	TEST CONDITIONS	MIN (Note 16)	TYP	MAX (Note 16)	UNIT
R_{TOTAL}	End-to-End Resistance			100		k Ω
	End-to-End Resistance Tolerance				±20	%
	Power Rating	+25°C, each potentiometer			50	mW
I_W	Wiper Current				±3	mA
R_W	Wiper Resistance	Wiper current = ±3mA, V_{CC} = 3V		150	500	Ω
R_W	Wiper Resistance	I_W = ±3mA, V_{CC} = 5V			100	Ω
Vv+	Voltage on V+ Pin	X9110 (Note 11)	+4.5		+5.5	V
		X9110-2.7 (Note 11)	+2.7		+5.5	V
Vv-	Voltage on V- Pin	X9110 (Note 11)	-5.5		-4.5	V
		X9110-2.7 (Note 11)	-5.5		-2.7	V
V_{TERM}	Voltage on any R_H or R_L Pin	V_{SS} = 0V	V-		V+	V
	Noise	Reference: 1V		-120		dBV
	Resolution			0.1		%
	Absolute Linearity (Note 8)	$R_{W(n)(actual)} - R_{W(n)(expected)}$, where n = 8 to 1006			±1	MI (Note 10)
		$R_{W(n)(actual)} - R_{W(n)(expected)}$ (Note 12)			±1.5	MI (Note 10)
	Relative Linearity (Note 9)	$R_{W(m+1)} - [R_{W(m)} + MI]$, where m = 8 to 1006			±0.5	MI (Note 10)
		$R_{W(m+1)} - [R_{W(m)} + MI]$ (Note 12)			±1	MI (Note 10)
	Temperature Coefficient of R_{TOTAL}			±300		ppm/°C
	Ratiometric Temperature Coefficient				20	ppm/°C
$C_H/C_L/C_W$	Potentiometer Capacitances	See macromodel		10/10/25		pF

NOTES:

- Absolute linearity is utilized to determine actual wiper voltage versus expected voltage as determined by wiper position when used as a potentiometer.
- Relative linearity is utilized to determine the actual change in voltage between two successive tap positions when used as a potentiometer. It is a measure of the error in step size.
- $MI = RTOT/1023$ or $(R_H - R_L)/1023$, single pot
- V_{CC} , V+, V- must reach their final values within 1ms of each other.
- n = 0, 1, 2, ..., 1023; m = 0, 1, 2, ..., 1022.

DC Operating Specifications

Over the recommended operating conditions unless otherwise specified.

SYMBOL	PARAMETER	TEST CONDITIONS	MIN (Note 16)	TYP	MAX (Note 16)	UNIT
I _{CC1}	V _{CC} Supply Current (active)	f _{SCK} = 2.5MHz, SO = Open, V _{CC} = 5.5V Other inputs = V _{SS}			400	μA
I _{CC2}	V _{CC} Supply Current (nonvolatile write)	f _{SCK} = 2.5MHz, SO = Open, V _{CC} = 5.5V Other inputs = V _{SS}		1	5	mA
I _{SB}	V _{CC} Current (standby)	SCK = SI = V _{SS} , Address = V _{SS} , CS = V _{CC} = 5.5V			5	μA
I _{LI}	Input Leakage Current	V _{IN} = V _{SS} to V _{CC}			10	μA
I _{LO}	Output Leakage Current	V _{OUT} = V _{SS} to V _{CC}			10	μA
V _{IH}	Input HIGH Voltage		V _{CC} × 0.7		V _{CC} + 1	V
V _{IL}	Input LOW Voltage		-1		V _{CC} × 0.3	V
V _{OL}	Output LOW Voltage	I _{OL} = 3mA			0.4	V
V _{OH}	Output HIGH Voltage	I _{OH} = -1mA, V _{CC} ≥ +3V	V _{CC} - 0.8			V
V _{OH}	Output HIGH Voltage	I _{OH} = -0.4mA, V _{CC} ≤ +3V	V _{CC} - 0.4			V

Endurance and Data Retention

PARAMETER	MIN	UNITS
Minimum Endurance	100,000	Data changes per bit per register
Data Retention	100	years

Capacitance

SYMBOL	TEST	TEST CONDITIONS	MAX	UNIT
C _{IN/OUT} (Notes 11, 13)	Input/Output Capacitance (SI)	V _{OUT} = 0V	8	pF
C _{OUT} (Note 13)	Output Capacitance (SO)	V _{OUT} = 0V	8	pF
C _{IN} (Note 13)	Input Capacitance (AO, CS, WP, HOLD, and SCK)	V _{IN} = 0V	6	pF

Power-up Timing

SYMBOL	PARAMETER	MIN	MAX	UNIT
t _r V _{CC} (Note 13)	V _{CC} Power-Up Rate	0.2	50	V/ms
t _{PUR} (Notes 13, 14)	Power-Up to Initiation of Read Operation		1	ms
t _{PUW} (Note 14)	Power-Up to Initiation of Write Operation		50	ms

NOTES:

- Limits established by characterization and are not production tested.
- t_{PUR} and t_{PUW} are the delays required from the time the (last) power supply (V_{CC}) is stable until the specific instruction can be issued.
- ESD Rating on R_H, R_L, R_W pins is 1.5kV (HBM, 1.0μA leakage maximum), ESD rating on all other pins is 2.0kV.
- Parts are 100% tested at +25°C. Over-temperature limits established by characterization and are not production tested.

AC Test Conditions

Input Pulse Levels	V _{CC} × 0.1 to V _{CC} × 0.9
Input Rise and Fall Times	10ns
Input and Output Timing Level	V _{CC} × 0.5

Equivalent A.C. Load Circuit

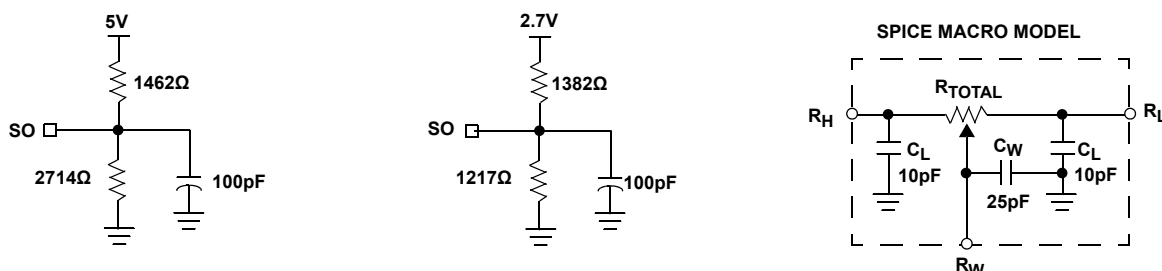

AC Timing

SYMBOL	PARAMETER	MIN	MAX	UNIT
f_{SCK}	SSI/SPI Clock Frequency		2.5	MHz
t_{CYC}	SSI/SPI Clock Cycle Time	400		ns
t_{WH}	SSI/SPI Clock High Time	150		ns
t_{WL}	SSI/SPI Clock Low Time	150		ns
t_{LEAD}	Lead Time	150		ns
t_{LAG}	Lag Time	150		ns
t_{SU}	SI, SCK, \overline{HOLD} and \overline{CS} Input Set-Up Time	50		ns
t_H	SI, SCK, \overline{HOLD} and \overline{CS} Input Hold Time	50		ns
t_{RI}	SI, SCK, \overline{HOLD} and \overline{CS} Input Rise Time		50	ns
t_{FI}	SI, SCK, \overline{HOLD} and \overline{CS} Input Fall Time		50	ns
t_{DIS}	SO Output Disable Time	0	500	ns
t_V	SO Output Valid Time		100	ns
t_{HO}	SO Output Hold Time	0		ns
t_{RO}	SO Output Rise Time		50	ns
t_{FO}	SO Output Fall Time		50	ns
t_{HOLD}	\overline{HOLD} Time	400		ns
t_{HSU}	\overline{HOLD} Set-Up Time	50		ns
t_{HH}	\overline{HOLD} Hold Time	50		ns
t_{HZ}	\overline{HOLD} Low to Output in High Z		100	ns
t_{LZ}	\overline{HOLD} High to Output in Low Z		100	ns
T_I	Noise Suppression Time Constant at SI, SCK, \overline{HOLD} and \overline{CS} Inputs		20	ns
t_{CS}	\overline{CS} Deselect Time	100		ns
t_{WPASU}	\overline{WP} , A0 Set-Up Time	0		ns
t_{WPAH}	\overline{WP} , A0 Hold Time	0		ns

High-Voltage Write Cycle Timing

SYMBOL	PARAMETER	TYP	MAX	UNIT
t_{WR}	High-Voltage Write Cycle Time (store instructions)	5	10	ms

XDCP Timing

SYMBOL	PARAMETER	MIN	MAX	UNIT
t_{WRP0}	Wiper Response Time After the Third (Last) Power Supply is Stable	5	10	μs
t_{WRL}	Wiper Response Time After Instruction Issued (All Load Instructions)	5	10	μs

Symbol Table

WAVEFORM	INPUTS	OUTPUTS
	Must be steady	Will be steady
	May change from LOW to HIGH	Will change from LOW to HIGH
	May change from HIGH to LOW	Will change from HIGH to LOW
	Don't Care: Changes Allowed	Changing: State Not Known
	N/A	Center Line is High Impedance

Timing Diagrams

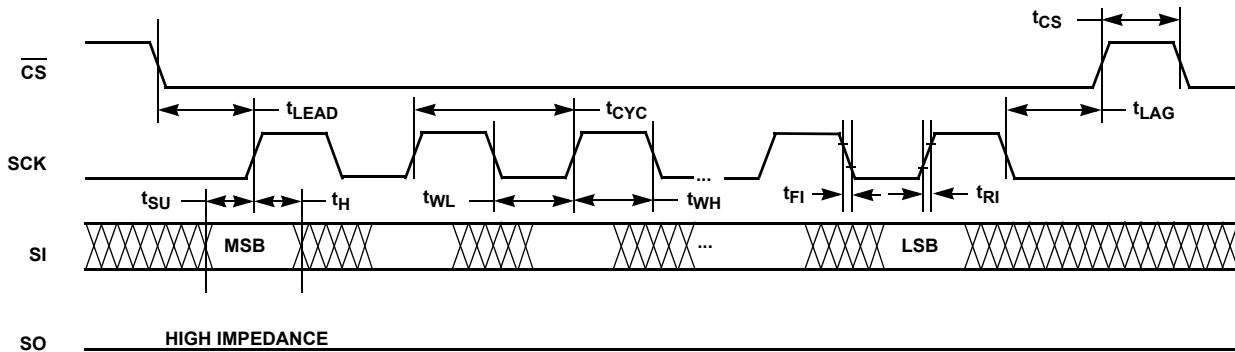

FIGURE 7. INPUT TIMING

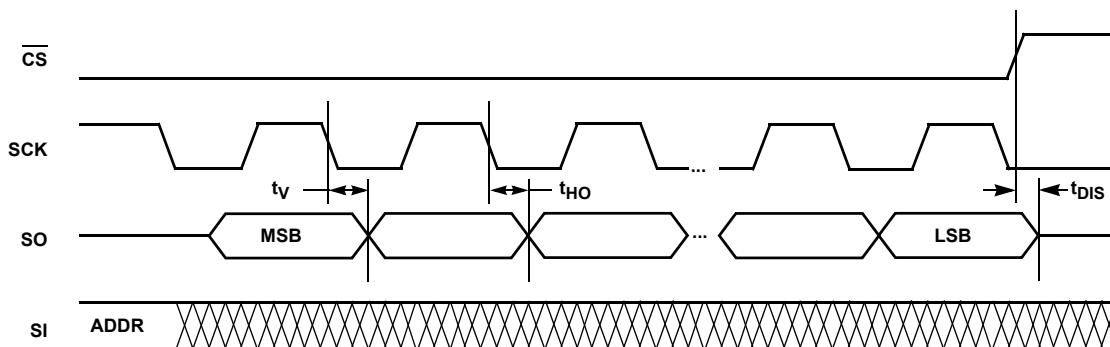

FIGURE 8. OUTPUT TIMING

Timing Diagrams (Continued)

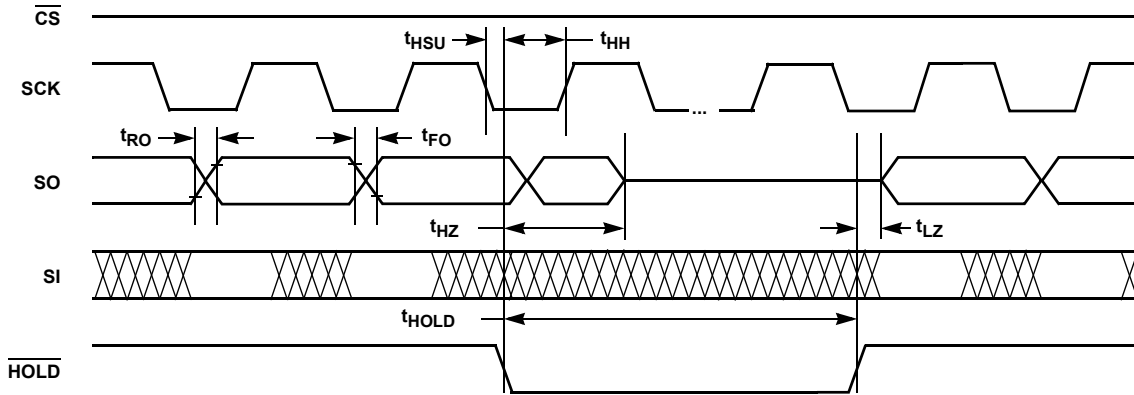

FIGURE 9. HOLD TIMING

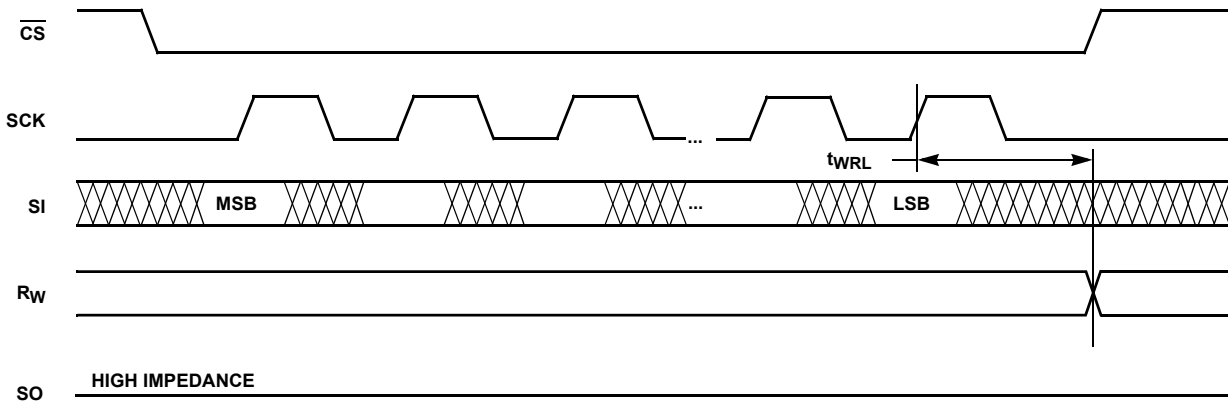

FIGURE 10. XDCP TIMING (FOR ALL LOAD INSTRUCTIONS)

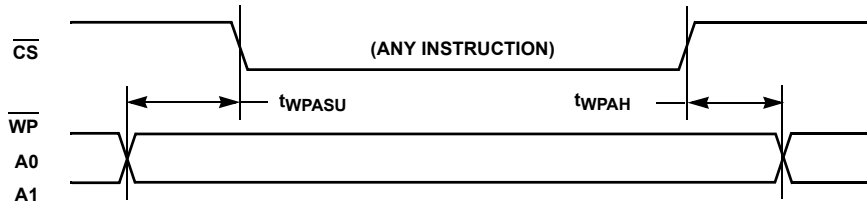

FIGURE 11. WRITE PROTECT AND DEVICE ADDRESS PINS TIMING

Applications information

Basic Configurations of Electronic Potentiometers

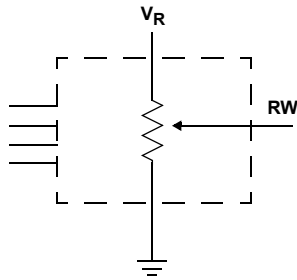

FIGURE 12. THREE TERMINAL POTENTIOMETER;
VARIABLE VOLTAGE DIVIDER

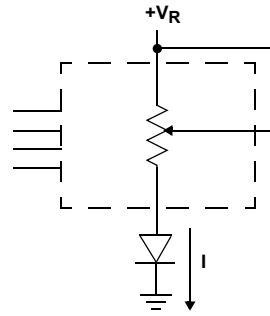
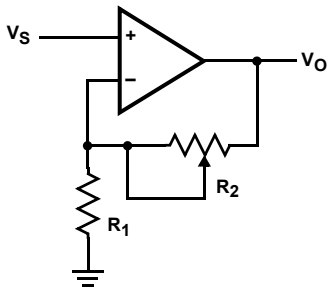

FIGURE 13. TWO TERMINAL VARIABLE RESISTOR;
VARIABLE CURRENT

Application Circuits



$$V_O = (1 + R_2/R_1)V_S$$

FIGURE 14. NONINVERTING AMPLIFIER

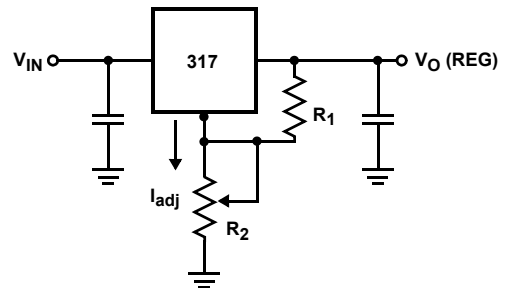

$$V_O \text{ (REG)} = 1.25V (1 + R_2/R_1) + I_{adj} R_2$$

FIGURE 15. VOLTAGE REGULATOR

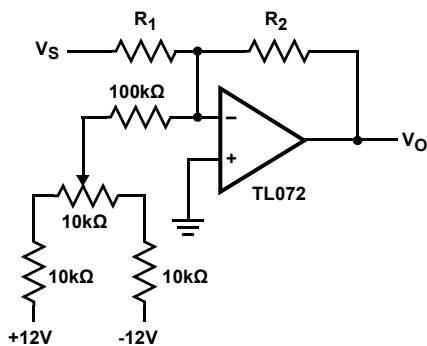
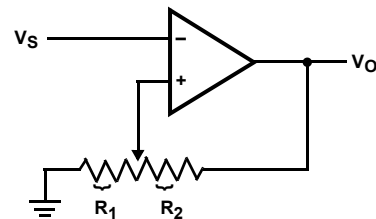

FIGURE 16. OFFSET VOLTAGE ADJUSTMENT



$$V_{UL} = \{R_1/(R_1 + R_2)\} V_O(\text{max})$$

$$R_{LL} = \{R_1/(R_1 + R_2)\} V_O(\text{min})$$

FIGURE 17. COMPARATOR WITH HYSTERESIS

Application Circuits (continued)

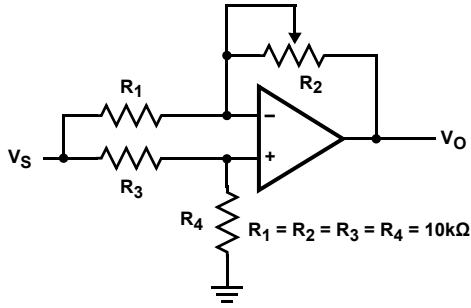

$$V_O = G V_S$$

$$-1/2 \leq G \leq +1/2$$

FIGURE 18. ATTENUATOR

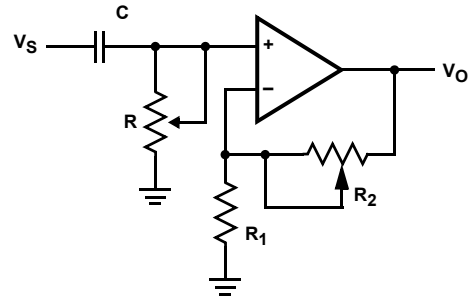

$$G_O = 1 + R_2/R_1$$

$$f_c = 1/(2\pi RC)$$

FIGURE 19. FILTER

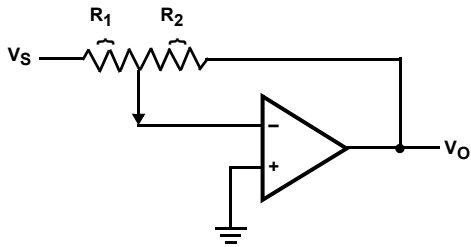

$$V_O = G V_S$$

$$G = -R_2/R_1$$

FIGURE 20. INVERTING AMPLIFIER

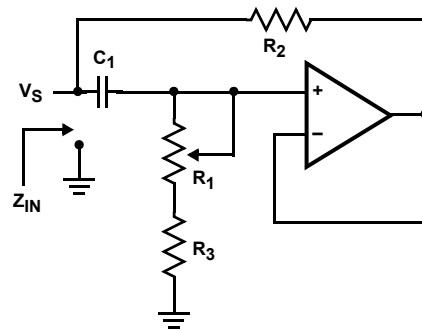

$$Z_{IN} = R_2 + s R_2 (R_1 + R_3) \quad C_1 = R_2 + s L_{eq}$$

$$(R_1 + R_3) \gg R_2$$

FIGURE 21. EQUIVALENT L-R CIRCUIT

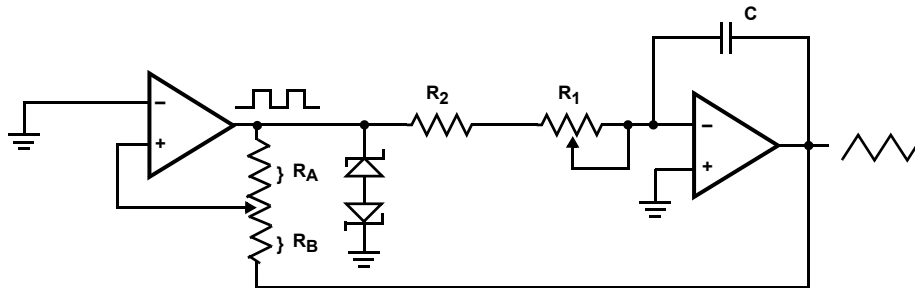

$$\text{frequency} \propto R_1, R_2, C$$

$$\text{amplitude} \propto R_A, R_B$$

FIGURE 22. FUNCTION GENERATOR

Revision History The revision history provided is for informational purposes only and is believed to be accurate, however, not warranted. Please visit our website to make sure that you have the latest revision.

DATE	REVISION	CHANGE
October 28, 2016	FN8158.5	Added Related Literature section on page 1. Updated f_{SCK} maximum specification on page 12.
August 3, 2016	FN8158.4	Updated entire datasheet applying Intersil's new standards. Updated Note 1 and added Note 3. Changed the maximum limit for parameter Vcc Current (standby) ISB from 3 μ A to 5 μ A on page 11. Added Revision History and About Intersil sections. Updated POD to latest revision changes are as follows: Updated drawing to remove table and added land pattern.

About Intersil

Intersil Corporation is a leading provider of innovative power management and precision analog solutions. The company's products address some of the largest markets within the industrial and infrastructure, mobile computing and high-end consumer markets.

For the most updated datasheet, application notes, related documentation and related parts, please see the respective product information page found at www.intersil.com.

You may report errors or suggestions for improving this datasheet by visiting www.intersil.com/ask.

Reliability reports are also available from our website at www.intersil.com/support.

© Copyright Intersil Americas LLC 2005-2016. All Rights Reserved.
All trademarks and registered trademarks are the property of their respective owners.

For additional products, see www.intersil.com/en/products.html

Intersil products are manufactured, assembled and tested utilizing ISO9001 quality systems as noted in the quality certifications found at www.intersil.com/en/support/qualandreliability.html

Intersil products are sold by description only. Intersil may modify the circuit design and/or specifications of products at any time without notice, provided that such modification does not, in Intersil's sole judgment, affect the form, fit or function of the product. Accordingly, the reader is cautioned to verify that datasheets are current before placing orders. Information furnished by Intersil is believed to be accurate and reliable. However, no responsibility is assumed by Intersil or its subsidiaries for its use; nor for any infringements of patents or other rights of third parties which may result from its use. No license is granted by implication or otherwise under any patent or patent rights of Intersil or its subsidiaries.

For information regarding Intersil Corporation and its products, see www.intersil.com

Package Outline Drawing

M14.173

14 LEAD THIN SHRINK SMALL OUTLINE PACKAGE (TSSOP)

Rev 3, 10/09

For the most recent package outline drawing, see [M14.173](#).

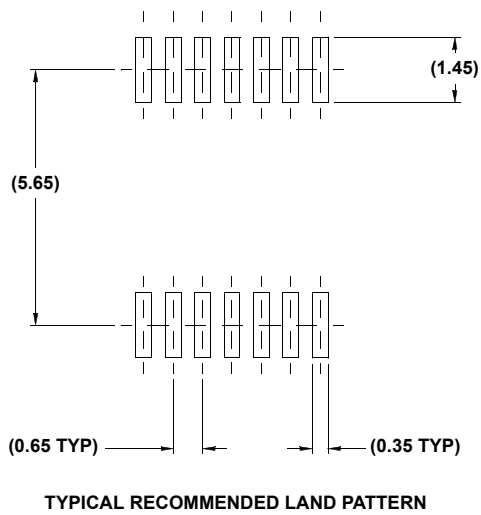
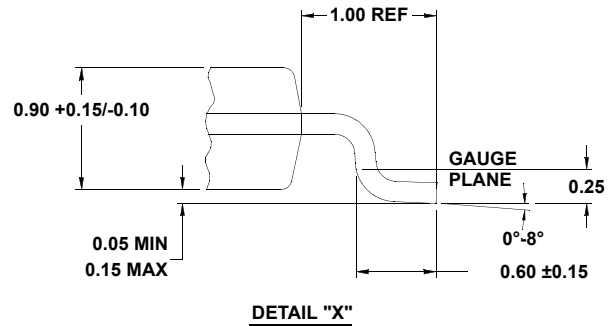
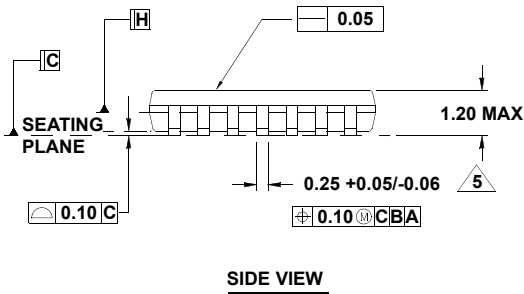
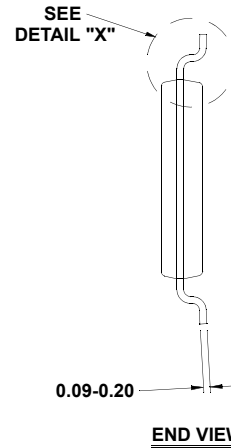
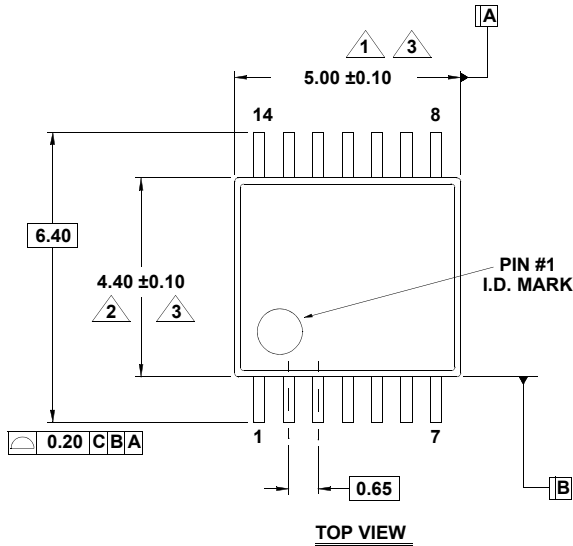

NOTES:

1. Dimension does not include mold flash, protrusions or gate burrs. Mold flash, protrusions or gate burrs shall not exceed 0.15 per side.
2. Dimension does not include interlead flash or protrusion. Interlead flash or protrusion shall not exceed 0.25 per side.
3. Dimensions are measured at datum plane H.
4. Dimensioning and tolerancing per ASME Y14.5M-1994.
5. Dimension does not include dambar protrusion. Allowable protrusion shall be 0.80mm total in excess of dimension at maximum material condition. Minimum space between protrusion and adjacent lead is 0.07mm.
6. Dimension in () are for reference only.
7. Conforms to JEDEC MO-153, variation AB-1.