

## X9428 Low Noise/Low Power/2-Wire Bus

Single Digitally Controlled Potentiometer (XDCP™)

FN8197  
Rev 1.00  
April 26, 2006

### FEATURES

- **Solid state potentiometer**
- **2-wire serial interface**
- **Register oriented format**
  - Direct Read/Write/Transfer wiper position
  - Store as many as four positions per potentiometer
- **Power supplies**
  - $V_{CC} = 2.7V$  to  $5.5V$
  - $V+ = 2.7V$  to  $5.5V$
  - $V- = -2.7V$  to  $-5.5V$
- **Low power CMOS**
  - Standby current  $< 1\mu A$
  - Ideal for battery operated applications
- **High reliability**
  - Endurance—100,000 Data changes per bit per register
  - Register data retention—100 years
- **4-bytes of nonvolatile memory**
- **10k $\Omega$  resistor array**
- **Resolution: 64 taps each potentiometer**
- **16 Ld SOIC, 14 Ld TSSOP packages**
- **Pb-free plus anneal available (RoHS compliant)**

### DESCRIPTION

The X9428 integrates a digitally controlled potentiometers (XDCP) on a monolithic CMOS integrated microcircuit.

The digitally controlled potentiometer is implemented using 63 resistive elements in a series array. Between each element are tap points connected to the wiper terminal through switches. The position of the wiper on the array is controlled by the user through the 2-wire bus interface. Each potentiometer has associated with it a volatile Wiper Counter Register (WCR) and 4 nonvolatile Data Registers (DR0:DR3) that can be directly written to and read by the user. The contents of the WCR controls the position of the wiper on the resistor array through the switches. Power-up recalls the contents of DR0 to the WCR.

The XDCP can be used as a three-terminal potentiometer or as a two-terminal variable resistor in a wide variety of applications including control, parameter adjustments, and signal processing.

### BLOCK DIAGRAM

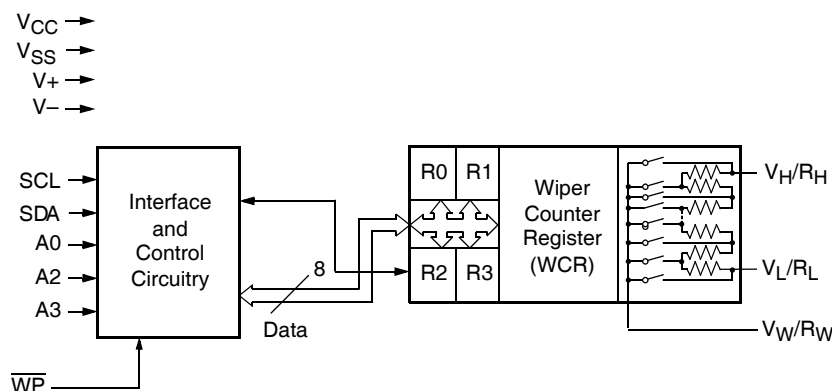

**Ordering Information**

PART NUMBER	PART MARKING	V <sub>CC</sub> LIMITS (V)	POTENTIOMETER ORGANIZATION (k $\Omega$ )	TEMP. RANGE (°C)	PACKAGE	PKG. DWG. #		
X9428WS16*	X9428WS	5 to $\pm$ 10%	10	0 to +70	16 Ld SOIC (300 mil)	M16.3		
X9428WS16Z* (Note)	X9428WS Z			0 to +70	16 Ld SOIC (300 mil) (Pb-free)	M16.3		
X9428WS16I*	X9428WS I			-40 to +85	16 Ld SOIC (300 mil)	M16.3		
X9428WS16IZ* (Note)	X9428WS ZI			-40 to +85	16 Ld SOIC (300 mil) (Pb-free)	M16.3		
X9428WV14*	X9428 W			0 to +70	14 Ld TSSOP (4.4mm)	M14.173		
X9428WV14Z* (Note)	X9428 Z			0 to +70	14 Ld TSSOP (4.4mm) (Pb-free)	M14.173		
X9428WV14I*	X9428 WI			-40 to +85	14 Ld TSSOP (4.4mm)	M14.173		
X9428WV14IZ* (Note)	X9428 ZI			-40 to +85	14 Ld TSSOP (4.4mm) (Pb-free)	M14.173		
X9428YS16*	X9428YS			2.7 to 5.5	10	0 to +70	16 Ld SOIC (300 mil)	M16.3
X9428YS16Z* (Note)	X9428YS Z					0 to +70	16 Ld SOIC (300 mil) (Pb-free)	M16.3
X9428YS16I*	X9428YS I					-40 to +85	16 Ld SOIC (300 mil)	M16.3
X9428YS16IZ* (Note)	X9428YS ZI					-40 to +85	16 Ld SOIC (300 mil) (Pb-free)	M16.3
X9428YV14*	X9428 Y					0 to +70	14 Ld TSSOP (4.4mm)	M14.173
X9428YV14Z* (Note)	X9428 YZ					0 to +70	14 Ld TSSOP (4.4mm) (Pb-free)	M14.173
X9428YV14I*	X9428 YI	-40 to +85	14 Ld TSSOP (4.4mm)			M14.173		
X9428YV14IZ* (Note)	X9428 YZI	-40 to +85	14 Ld TSSOP (4.4mm) (Pb-free)			M14.173		
X9428WS16-2.7*	X9428WS F	2	2			0 to +70	16 Ld SOIC (300 mil)	M16.3
X9428WS16Z-2.7* (Note)	X9428WS ZF					0 to +70	16 Ld SOIC (300 mil) (Pb-free)	M16.3
X9428WS16I-2.7*	X9428WS G					-40 to +85	16 Ld SOIC (300 mil)	M16.3
X9428WS16IZ-2.7* (Note)	X9428WS ZG					-40 to +85	16 Ld SOIC (300 mil) (Pb-free)	M16.3
X9428WV14-2.7*	X9428 WF					0 to +70	14 Ld TSSOP (4.4mm)	M14.173
X9428WV14Z-2.7* (Note)	X9428 ZF					0 to +70	14 Ld TSSOP (4.4mm) (Pb-free)	M14.173
X9428WV14I-2.7*	X9428 WG			-40 to +85	14 Ld TSSOP (4.4mm)	M14.173		
X9428WV14IZ-2.7* (Note)	X9428 ZG			-40 to +85	14 Ld TSSOP (4.4mm) (Pb-free)	M14.173		
X9428YS16-2.7*	X9428YS F			0 to +70	16 Ld SOIC (300 mil)	M16.3		
X9428YS16Z-2.7* (Note)	X9428YS ZF			0 to +70	16 Ld SOIC (300 mil) (Pb-free)	M16.3		

**Ordering Information** (Continued)

PART NUMBER	PART MARKING	V <sub>CC</sub> LIMITS (V)	POTENTIOMETER ORGANIZATION (k $\Omega$ )	TEMP. RANGE (°C)	PACKAGE	PKG. DWG. #
X9428YS16I-2.7*	X9428YS G	2.7 to 5.5	2	-40 to +85	16 Ld SOIC (300 mil)	M16.3
X9428YS16IZ-2.7* (Note)	X9428YS ZG			-40 to +85	16 Ld SOIC (300 mil) (Pb-free)	M16.3
X9428YV14-2.7*	X9428 YF			0 to +70	14 Ld TSSOP (4.4mm)	M14.173
X9428YV14Z-2.7* (Note)	X9428 YZF			0 to +70	14 Ld TSSOP (4.4mm) (Pb-free)	M14.173
X9428YV14I-2.7*	X9428 YG			-40 to +85	14 Ld TSSOP (4.4mm)	M14.173
X9428YV14IZ-2.7* (Note)	X9428 YZG			-40 to +85	14 Ld TSSOP (4.4mm) (Pb-free)	M14.173

\*Add "T1" suffix for tape and reel.

NOTE: Intersil Pb-free plus anneal products employ special Pb-free material sets; molding compounds/die attach materials and 100% matte tin plate termination finish, which are RoHS compliant and compatible with both SnPb and Pb-free soldering operations. Intersil Pb-free products are MSL classified at Pb-free peak reflow temperatures that meet or exceed the Pb-free requirements of IPC/JEDEC J STD-020.

## PIN DESCRIPTIONS

### Host Interface Pins

#### Serial Clock (SCL)

The SCL input is used to clock data into and out of the X9428.

#### Serial Data (SDA)

SDA is a bidirectional pin used to transfer data into and out of the device. It is an open drain output and may be wire-ORed with any number of open drain or open collector outputs. An open drain output requires the use of a pull-up resistor. For selecting typical values, refer to the guidelines for calculating typical values on the bus pull-up resistors graph.

#### Device Address (A<sub>0</sub>, A<sub>2</sub>, A<sub>3</sub>)

The Address inputs are used to set the least significant 3 bits of the 8-bit slave address. A match in the slave address serial data stream must be made with the Address input in order to initiate communication with the X9428. A maximum of 8 devices may occupy the 2-wire serial bus.

### Potentiometer Pins

#### R<sub>H</sub>/V<sub>H</sub>, R<sub>L</sub>/V<sub>L</sub>

The R<sub>H</sub>/V<sub>H</sub> and R<sub>L</sub>/V<sub>L</sub> inputs are equivalent to the terminal connections on either end of a mechanical potentiometer.

#### R<sub>W</sub>/V<sub>W</sub>

The wiper outputs are equivalent to the wiper output of a mechanical potentiometer.

#### Hardware Write Protect Input $\overline{WP}$

The  $\overline{WP}$  pin when low prevents nonvolatile writes to the Data Registers.

#### Analog Supply V<sub>+</sub>, V<sub>-</sub>

The Analog Supply V<sub>+</sub>, V<sub>-</sub> are the supply voltages for the XDCP analog section.

## PIN CONFIGURATION

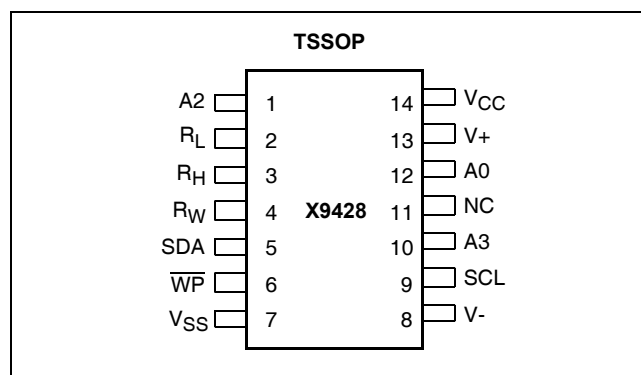
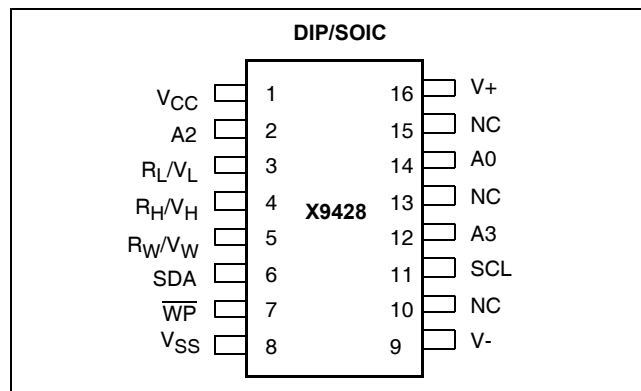

## PIN NAMES

Symbol	Description
SCL	Serial clock
SDA	Serial data
A0, A2, A3	Device address
R <sub>H</sub> /V <sub>H</sub> , V <sub>L</sub> /R <sub>H</sub>	Potentiometer Pins (terminal equivalent)
R <sub>W</sub> /V <sub>W</sub>	Potentiometer Pin (wiper equivalent)
$\overline{WP}$	Hardware write protection
V <sub>+</sub> , V <sub>-</sub>	Analog and voltage follower
V <sub>CC</sub>	System supply voltage
V <sub>SS</sub>	System ground
NC	No connection

## PRINCIPLES OF OPERATION

The X9428 is a highly integrated microcircuit incorporating a resistor array and its associated registers and counters and the serial interface logic providing direct communication between the host and the XDCP potentiometers.

### Serial Interface

The X9428 supports a bidirectional bus oriented protocol. The protocol defines any device that sends data onto the bus as a transmitter and the receiving device as the receiver. The device controlling the transfer is a master and the device being controlled is the slave. The master will always initiate data transfers and provide the clock for both transmit and receive operations. Therefore, the X9428 will be considered a slave device in all applications.

### Clock and Data Conventions

Data states on the SDA line can change only during SCL LOW periods ( $t_{LOW}$ ). SDA state changes during SCL HIGH are reserved for indicating start and stop conditions.

### Start Condition

All commands to the X9428 are preceded by the start condition, which is a HIGH to LOW transition of SDA while SCL is HIGH ( $t_{HIGH}$ ). The X9428 continuously monitors the SDA and SCL lines for the start condition and will not respond to any command until this condition is met.

### Stop Condition

All communications must be terminated by a stop condition, which is a LOW to HIGH transition of SDA while SCL is HIGH.

### Acknowledge

Acknowledge is a software convention used to provide a positive handshake between the master and slave devices on the bus to indicate the successful receipt of data. The transmitting device, either the master or the slave, will release the SDA bus after transmitting eight bits. The master generates a ninth clock cycle and during this period the receiver pulls the SDA line LOW to acknowledge that it successfully received the eight bits of data.

The X9428 will respond with an acknowledge after recognition of a start condition and its slave address and once again after successful receipt of the command byte. If the command is followed by a data byte the X9428 will respond with a final acknowledge.

### Array Description

The X9428 is comprised of a resistor array. The array contains 63 discrete resistive segments that are connected in series. The physical ends of the array are equivalent to the fixed terminals of a mechanical potentiometer ( $V_H/R_H$  and  $V_L/R_L$  inputs).

At both ends of the array and between each resistor segment is a CMOS switch connected to the wiper ( $V_W/R_W$ ) output. Within each individual array only one switch may be turned on at a time. These switches are controlled by the Wiper Counter Register (WCR). The six bits of the WCR are decoded to select, and enable, one of sixty-four switches.

The WCR may be written directly, or it can be changed by transferring the contents of one of four associated Data Registers into the WCR. These Data Registers and the WCR can be read and written by the host system.

### Device Addressing

Following a start condition the master must output the address of the slave it is accessing. The most significant four bits of the slave address are the device type identifier (refer to Figure 1 below). For the X9428 this is fixed as 0101[B].

**Figure 1. Slave Address**

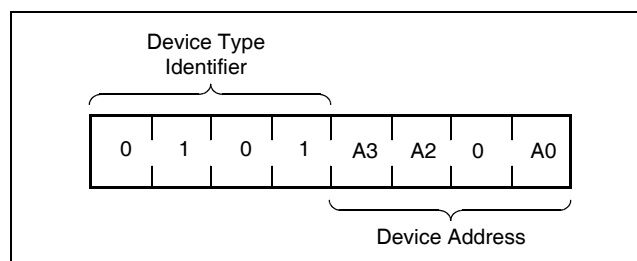

The next four bits of the slave address are the device address. The physical device address is defined by the state of the  $A_0$ ,  $A_2$ ,  $A_3$  inputs. The X9428 compares the serial data stream with the address input state; a successful compare of all four address bits is required for the X9428 to respond with an acknowledge. The  $A_0$ ,  $A_2$ ,  $A_3$  inputs can be actively driven by CMOS input signals or tied to  $V_{CC}$  or  $V_{SS}$ .

**Acknowledge Polling**

The disabling of the inputs, during the internal nonvolatile write operation, can be used to take advantage of the typical 5ms EEPROM write cycle time. Once the stop condition is issued to indicate the end of the nonvolatile write command the X9428 initiates the internal write cycle. ACK polling can be initiated immediately. This involves issuing the start condition followed by the device slave address. If the X9428 is still busy with the write operation no ACK will be returned. If the X9428 has completed the write operation an ACK will be returned, and the master can then proceed with the next operation.

**Flow 1. ACK Polling Sequence**

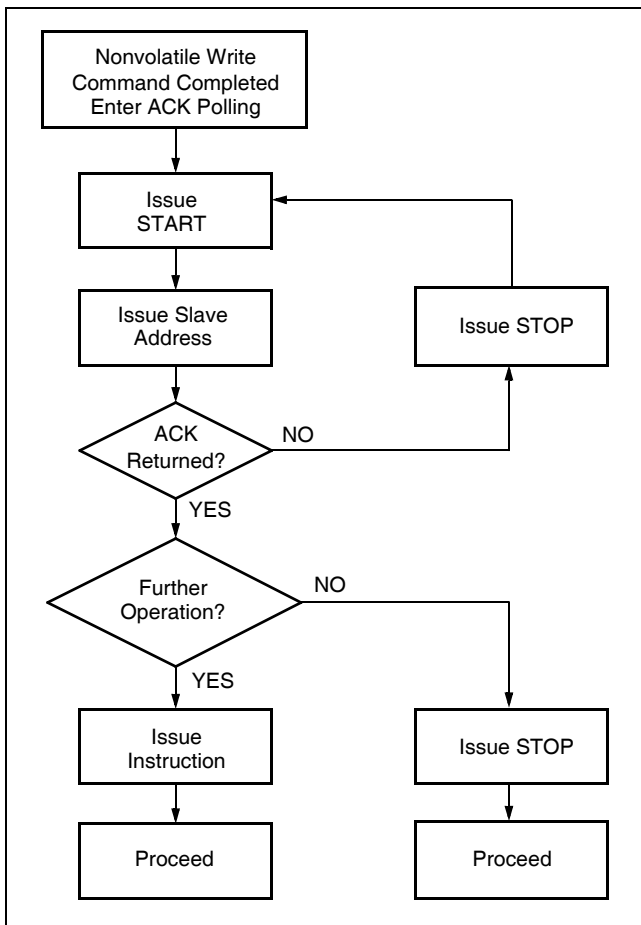

**Instruction Structure**

The next byte sent to the X9428 contains the instruction and register pointer information. The four most significant bits are the instruction. The next four bits point to one of four associated registers. The format is shown below in Figure 2.

**Figure 2. Instruction Byte Format**

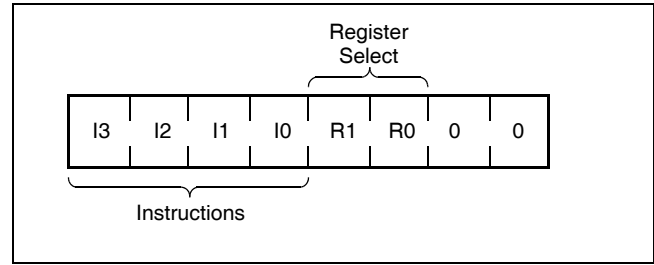

The four high order bits define the instruction. The next two bits (R1 and R0) select one of the four registers that is to be acted upon when a register oriented instruction is issued. Bits 0 and 1 are defined to be 0.

Four of the seven instructions end with the transmission of the instruction byte. The basic sequence is illustrated in Figure 3. These two-byte instructions exchange data between the Wiper Counter Register and one of the Data Registers. A transfer from a Data Register to a Wiper Counter Register is essentially a write to a static RAM. The response of the wiper to this action will be delayed  $t_{WRL}$ . A transfer from the Wiper Counter Register (current wiper position), to a Data Register is a write to nonvolatile memory and takes a minimum of  $t_{WR}$  to complete.

Four instructions require a three-byte sequence to complete. These instructions transfer data between the host and the X9428; either between the host and one of the Data Registers or directly between the host and the Wiper Counter Register. These instructions are: Read Wiper Counter Register (read the current wiper position of the selected pot), write Wiper Counter Register (change current wiper position of the selected pot), read Data Register (read the contents of the selected nonvolatile register) and write Data Register (write a new value to the selected Data Register). The sequence of operations is shown in Figure 4.

**Figure 3. Two-Byte Instruction Sequence**

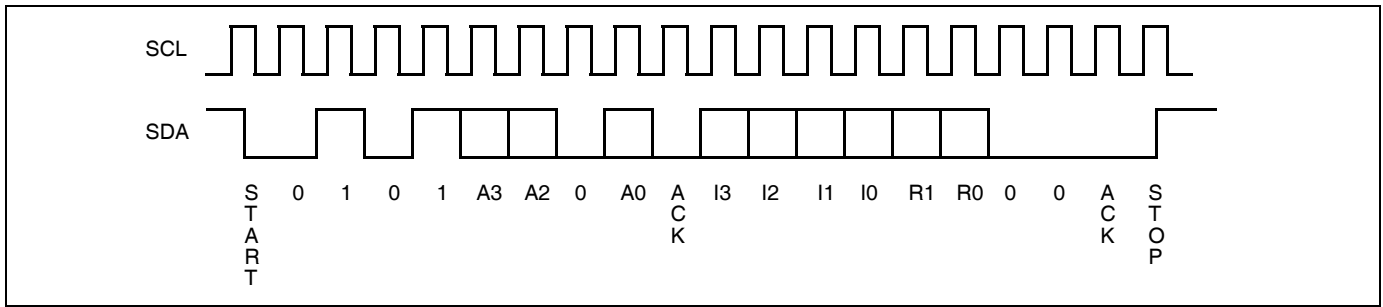

The Increment/Decrement command is different from the other commands. Once the command is issued and the X9428 has responded with an acknowledge, the master can clock the selected wiper up and/or down in one segment steps; thereby, providing a fine tuning capability to the host. For each SCL clock pulse ( $t_{HIGH}$ ) while SDA is HIGH, the selected wiper will move one

resistor segment towards the  $V_H/R_H$  terminal. Similarly, for each SCL clock pulse while SDA is LOW, the selected wiper will move one resistor segment towards the  $V_L/R_L$  terminal. A detailed illustration of the sequence and timing for this operation are shown in Figures 5 and 6 respectively.

**Table 1. Instruction Set**

Instruction	Instruction Set								Operation
	I <sub>3</sub>	I <sub>2</sub>	I <sub>1</sub>	I <sub>0</sub>	R <sub>1</sub>	R <sub>0</sub>	X <sub>1</sub>	X <sub>0</sub>	
Read Wiper Counter Register	1	0	0	1	0	0	0	0	Read the contents of the Wiper Counter Register
Write Wiper Counter Register	1	0	1	0	0	0	0	0	Write new value to the Wiper Counter Register
Read Data Register	1	0	1	1	1/0	1/0	0	0	Read the contents of the Data Register pointed to by R <sub>1</sub> - R <sub>0</sub>
Write Data Register	1	1	0	0	1/0	1/0	0	0	Write new value to the Data Register pointed to by R <sub>1</sub> - R <sub>0</sub>
XFR Data Register to Wiper Counter Register	1	1	0	1	1/0	1/0	0	0	Transfer the contents of the Data Register pointed to by R <sub>1</sub> - R <sub>0</sub> to its Wiper Counter Register
XFR Wiper Counter Register to Data Register	1	1	1	0	1/0	1/0	0	0	Transfer the contents of the Wiper Counter Register to the Data Register pointed to by R <sub>1</sub> - R <sub>0</sub>
Increment/Decrement Wiper Counter Register	0	0	1	0	0	0	0	1/0	Enable Increment/decrement of the Wiper Counter Register

Note: (7) 1/0 = data is one or zero

**Figure 4. Three-Byte Instruction Sequence**

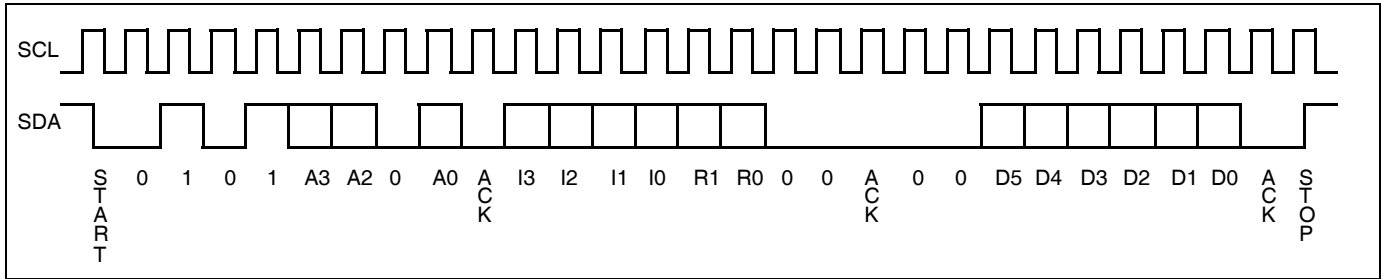

**Figure 5. Increment/Decrement Instruction Sequence**

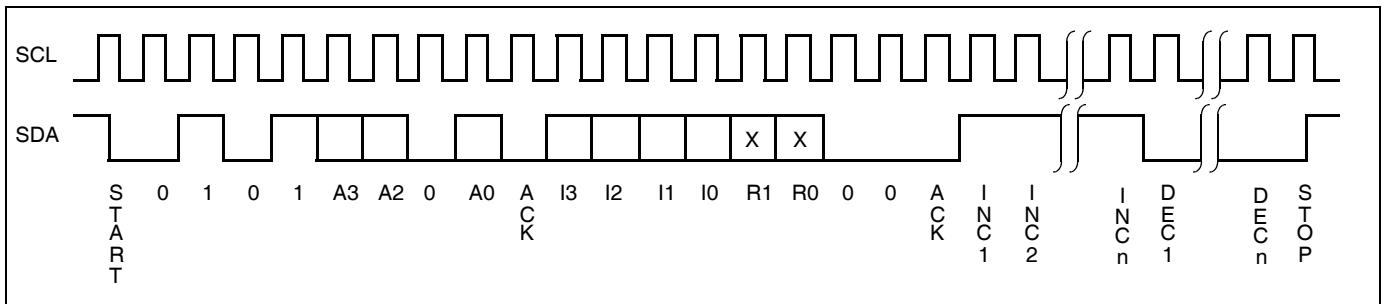

**Figure 6. Increment/Decrement Timing Limits**

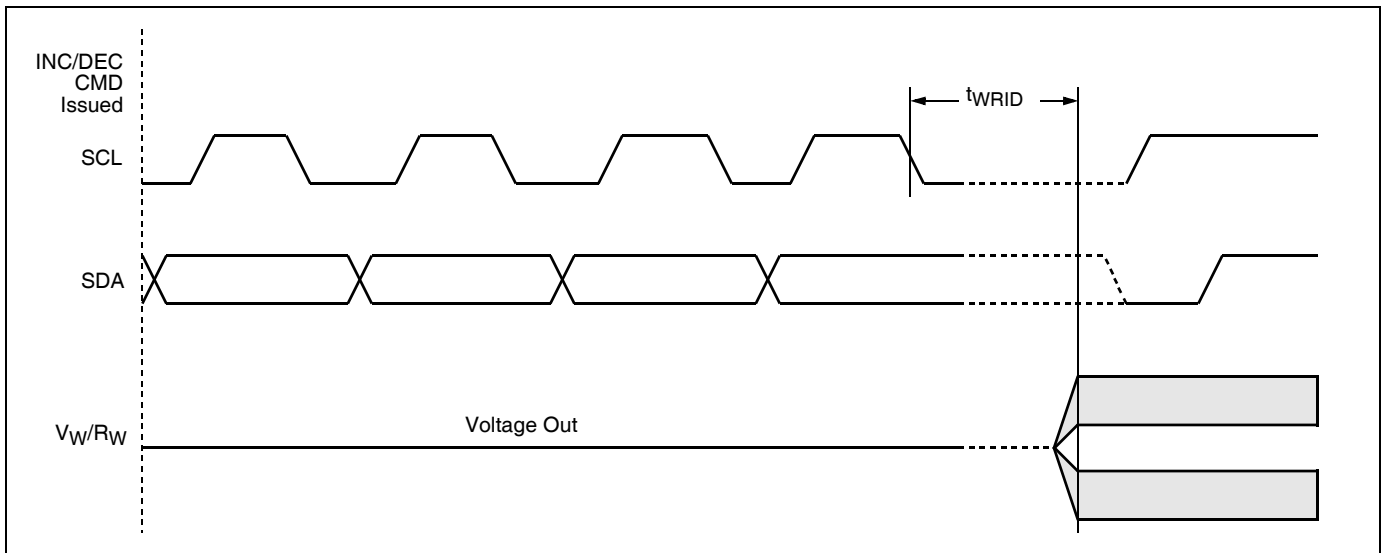



Figure 7. Acknowledge Response from Receiver

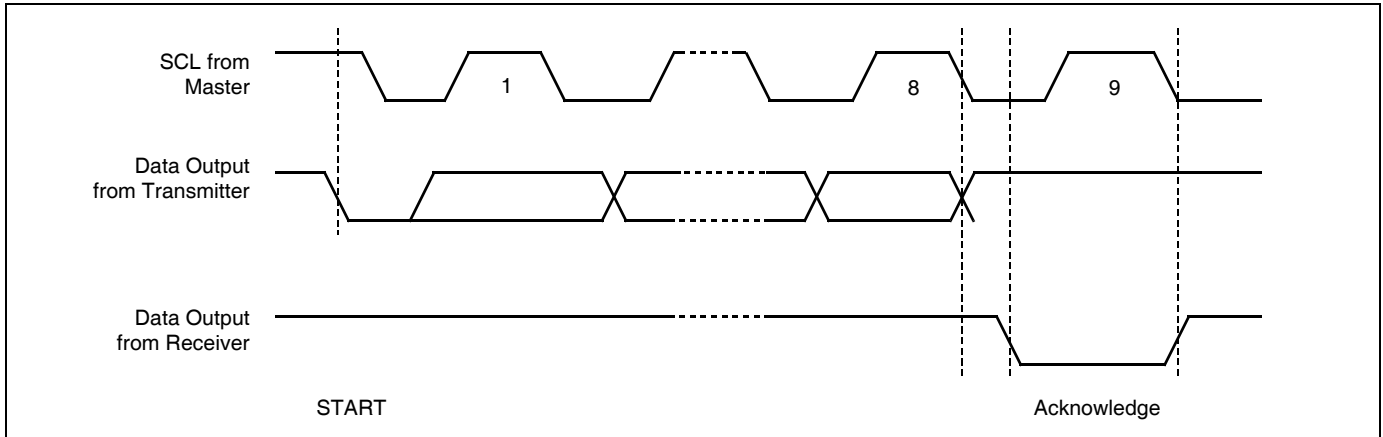
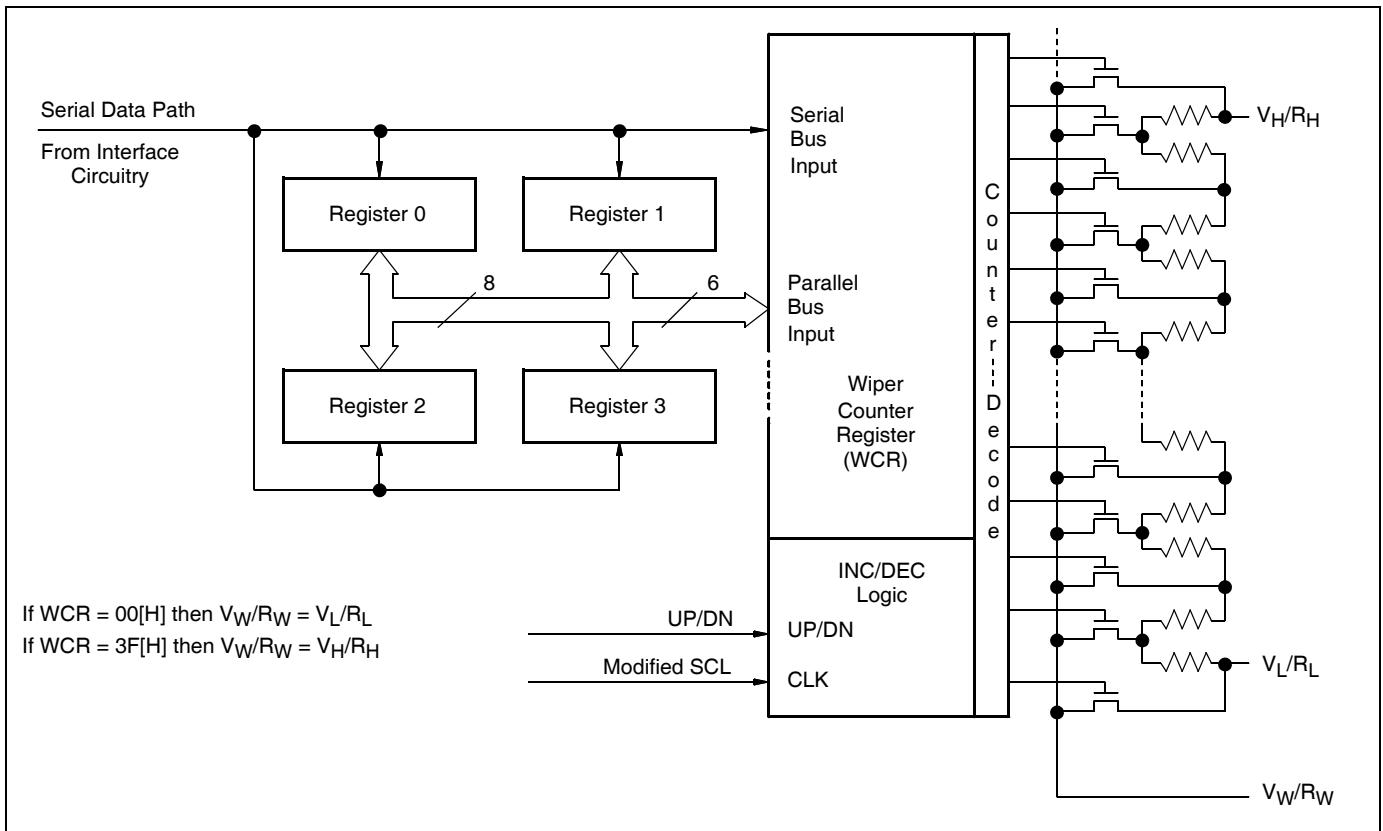

Figure 8. Detailed Potentiometer Block Diagram



## DETAILED OPERATION

The potentiometer has a Wiper Counter Register and four Data Registers. A detailed discussion of the register organization and array operation follows.

### Wiper Counter Register

The X9428 contains a Wiper Counter Register. The Wiper Counter Register can be envisioned as a 6-bit parallel and serial load counter with its outputs decoded to select one of sixty-four switches along its resistor array. The contents of the WCR can be altered in four ways: it may be written directly by the host via the write Wiper Counter Register instruction (serial load); it may be written indirectly by transferring the contents of one of four associated Data Registers via the XFR Data Register instruction (parallel load); it can be modified one step at a time by the Increment/Decrement instruction. Finally, it is loaded with the contents of its Data Register zero (DR0) upon power-up.

The WCR is a volatile register; that is, its contents are lost when the X9428 is powered-down. Although the register is automatically loaded with the value in DR0 upon power-up, it should be noted this may be different from the value present at power-down.

### Data Registers

The potentiometer has four nonvolatile Data Registers. These can be read or written directly by the host and data can be transferred between any of the four Data Registers and the Wiper Counter Register. It should be noted all operations changing data in one of these registers is a nonvolatile operation and will take a maximum of 10ms.

If the application does not require storage of multiple settings for the potentiometer, these registers can be used as regular memory locations that could possibly store system parameters or user preference data.

## Register Descriptions

### Data Registers, (6-Bit), Nonvolatile

D5	D4	D3	D2	D1	D0
NV	NV	NV	NV	NV	NV
(MSB)			(LSB)		

Four 6-bit Data Registers for each XDCP. (eight 6-bit registers in total).

- {D5~D0}: These bits are for general purpose not volatile data storage or for storage of up to four different wiper values. The contents of Data Register 0 are automatically moved to the Wiper Counter Register on power-up.

### Wiper Counter Register, (6-Bit), Volatile

WP5	WP4	WP3	WP2	WP1	WP0
V	V	V	V	V	V
(MSB)			(LSB)		

One 6-bit wiper counter register for each XDCP. (Four 6-bit registers in total.)

- {D5~D0}: These bits specify the wiper position of the respective XDCP. The Wiper Counter Register is loaded on power-up by the value in Data Register 0. The contents of the WCR can be loaded from any of the other Data Register or directly. The contents of the WCR can be saved in a DR.

**Instruction Format**

- Notes: (1) "MACK"/"SACK": stands for the acknowledge sent by the master/slave.  
 (2) "A3 ~ A0": stands for the device addresses sent by the master.  
 (3) "X": indicates that it is a "0" for testing purpose but physically it is a "don't care" condition.  
 (4) "I": stands for the increment operation, SDA held high during active SCL phase (high).  
 (5) "D": stands for the decrement operation, SDA held low during active SCL phase (high).

**Read Wiper Counter Register (WCR)**

S T A R T	device type identifier				device addresses				S A C K	instruction opcode								S A C K	wiper position (sent by slave on SDA)							M A C K	S T O P	
	0	1	0	1	A3	A2	0	A0		1	0	0	1	0	0	0	0		0	0	W P 5	W P 4	W P 3	W P 2	W P 1			W P 0
	0	1	0	1	A3	A2	0	A0		1	0	0	1	0	0	0	0		0	0	W P 5	W P 4	W P 3	W P 2	W P 1	W P 0		

**Write Wiper Counter Register (WCR)**

S T A R T	device type identifier				device addresses				S A C K	instruction opcode								S A C K	wiper position (sent by master on SDA)							S A C K	S T O P	
	0	1	0	1	A3	A2	0	A0		1	0	1	0	0	0	0	0		0	0	W P 5	W P 4	W P 3	W P 2	W P 1			W P 0
	0	1	0	1	A3	A2	0	A0		1	0	1	0	0	0	0	0		0	0	W P 5	W P 4	W P 3	W P 2	W P 1	W P 0		

**Read Data Register (DR)**

S T A R T	device type identifier				device addresses				S A C K	instruction opcode				register addresses				S A C K	wiper position/data (sent by slave on SDA)							M A C K	S T O P	
	0	1	0	1	A3	A2	0	A0		1	0	1	1	R1	R0	0	0		0	0	W P 5	W P 4	W P 3	W P 2	W P 1			W P 0
	0	1	0	1	A3	A2	0	A0		1	0	1	1	R1	R0	0	0		0	0	W P 5	W P 4	W P 3	W P 2	W P 1	W P 0		

**Write Data Register (DR)**

S T A R T	device type identifier				device addresses				S A C K	instruction opcode				register addresses				S A C K	wiper position/data (sent by master on SDA)							S A C K	S T O P	HIGH-VOLTAGE WRITE CYCLE	
	0	1	0	1	A3	A2	0	A0		1	1	0	0	R1	R0	0	0		0	0	W P 5	W P 4	W P 3	W P 2	W P 1				W P 0
	0	1	0	1	A3	A2	0	A0		1	1	0	0	R1	R0	0	0		0	0	W P 5	W P 4	W P 3	W P 2	W P 1	W P 0			

**XFR Data Register (DR) to Wiper Counter Register (WCR)**

S T A R T	device type identifier				device addresses				S A C K	instruction opcode				register addresses				S A C K	S T O P
	0	1	0	1	A3	A2	0	A0		1	1	0	1	R1	R0	0	0		
	0	1	0	1	A3	A2	0	A0		1	1	0	1	R1	R0	0	0		





**XFR Wiper Counter Register (WCR) to Data Register (DR)**

START	device type identifier				device addresses				ACK	instruction opcode				register addresses				ACK	STOP	HIGH-VOLTAGE WRITE CYCLE
	0	1	0	1	A <sub>3</sub>	A <sub>2</sub>	0	A <sub>0</sub>		1	1	1	0	R <sub>1</sub>	R <sub>0</sub>	0	0			

**Increment/Decrement Wiper Counter Register (WCR)**

START	device type identifier				device addresses				ACK	instruction opcode				increment/decrement (sent by master on SDA)				STOP					
	0	1	0	1	A <sub>3</sub>	A <sub>2</sub>	0	A <sub>0</sub>		0	0	1	0	0	0	0	0		I/D	I/D	·	·	·

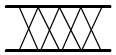
**SYMBOL TABLE**

WAVEFORM	INPUTS	OUTPUTS
	Must be steady	Will be steady
	May change from Low to High	Will change from Low to High
	May change from High to Low	Will change from High to Low
	Don't Care: Changes Allowed	Changing: State Not Known
	N/A	Center Line is High Impedance

**Guidelines for Calculating Typical Values of Bus Pull-Up Resistors**

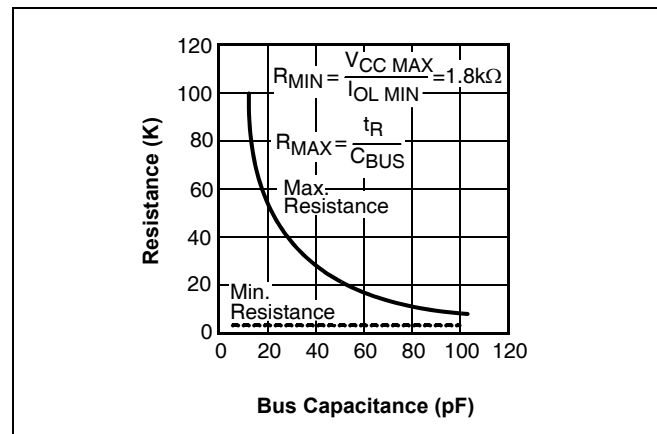

**ABSOLUTE MAXIMUM RATINGS**

Temperature under bias .....	-65°C to +135°C
Storage temperature .....	-65°C to +150°C
Voltage on SDA, SCL or any address input with respect to $V_{SS}$ .....	-1V to +7V
Voltage on V+ (referenced to $V_{SS}$ ) .....	10V
Voltage on V- (referenced to $V_{SS}$ ) .....	-10V
(V+) - (V-) .....	12V
Any $V_H/R_H$ .....	V+
Any $V_L/R_L$ .....	V-
Lead temperature (soldering, 10 seconds) .....	300°C
$I_W$ (10 seconds) .....	±12mA

**COMMENT**

Stresses above those listed under “Absolute Maximum Ratings” may cause permanent damage to the device. This is a stress rating only; functional operation of the device (at these or any other conditions above those listed in the operational sections of this specification) is not implied. Exposure to absolute maximum rating conditions for extended periods may affect device reliability.

**RECOMMENDED OPERATING CONDITIONS**

Temp	Min.	Max.
Commercial	0°C	+70°C
Industrial	-40°C	+85°C

Device	Supply Voltage ( $V_{CC}$ ) Limits
X9428	5V ± 10%
X9428-2.7	2.7V to 5.5V

**ANALOG CHARACTERISTICS** (Over recommended operating conditions unless otherwise stated.)

Symbol	Parameter		Limits				Test Conditions
			Min.	Typ.	Max.	Unit	
	End to end resistance tolerance				±20	%	
	Power rating				50	mW	25°C, each pot
$I_W$	Wiper current				±6	mA	
$R_W$	Wiper resistance			150	250	Ω	Wiper current = ± 1mA, $V_{CC}$ = 3V
				40	100	Ω	Wiper current = ± 1mA, $V_{CC}$ = 5V
V+	Voltage on V+ pin	X9428	+4.5		+5.5	V	
		X9428-2.7	+2.7		+5.5		
V-	Voltage on V- pin	X9428	-5.5		-4.5	V	
		X9428-2.7	-5.5		-2.7		
$V_{TERM}$	Voltage on any $V_H/R_H$ or $V_L/R_L$ pin		V-		V+	V	
	Noise			-140		dBV	Ref: 1kHz
	Resolution <sup>(4)</sup>			1.6		%	
	Absolute linearity <sup>(1)</sup>				±1	MI <sup>(3)</sup>	$V_{w(n)}(\text{actual}) - V_{w(n)}(\text{expected})$
	Relative linearity <sup>(2)</sup>				±0.2	MI <sup>(3)</sup>	$V_{w(n+1)} - [V_{w(n)} + MI]$
	Temperature Coefficient of $R_{TOTAL}$			±300		ppm/°C	
	Ratiometric Temperature Coefficient				±20	ppm/°C	
$C_H/C_L/C_W$	Potentiometer Capacitances			10/10/25		pF	See Circuit #3, Spice Macromodel

**D.C. OPERATING CHARACTERISTICS** (Over the recommended operating conditions unless otherwise specified.)

Symbol	Parameter	Limits				Test Conditions
		Min.	Typ.	Max.	Unit	
I <sub>CC1</sub>	V <sub>CC</sub> supply current (nonvolatile write)			1	mA	f <sub>SCL</sub> = 400kHz, SDA = Open, Other Inputs = V <sub>SS</sub>
I <sub>CC2</sub>	V <sub>CC</sub> supply current (move wiper, write, read)			100	μA	f <sub>SCL</sub> = 400kHz, SDA = Open, Other Inputs = V <sub>SS</sub>
I <sub>SB</sub>	V <sub>CC</sub> current (standby)			1	μA	SCL = SDA = V <sub>CC</sub> , Addr. = V <sub>SS</sub>
I <sub>LI</sub>	Input leakage current			10	μA	V <sub>IN</sub> = V <sub>SS</sub> to V <sub>CC</sub>
I <sub>LO</sub>	Output leakage current			10	μA	V <sub>OUT</sub> = V <sub>SS</sub> to V <sub>CC</sub>
V <sub>IH</sub>	Input HIGH voltage	V <sub>CC</sub> × 0.7		V <sub>CC</sub> × 0.5	V	
V <sub>IL</sub>	Input LOW voltage	-0.5		V <sub>CC</sub> × 0.1	V	
V <sub>OL</sub>	Output LOW voltage			0.4	V	I <sub>OL</sub> = 3mA

- Notes: (1) Absolute linearity is utilized to determine actual wiper voltage versus expected voltage as determined by wiper position when used as a potentiometer.  
(2) Relative linearity is utilized to determine the actual change in voltage between two successive tap positions when used as a potentiometer. It is a measure of the error in step size.  
(3) MI = RTOT/63 or (R<sub>H</sub> - R<sub>L</sub>)/63, single pot  
(4) Max. = all four arrays cascaded together, Typical = individual array resolutions.

**ENDURANCE AND DATA RETENTION**

Parameter	Min.	Unit
Minimum endurance	100,000	Data changes per bit per register
Data retention	100	Years

**CAPACITANCE**

Symbol	Test	Max.	Unit	Test Conditions
C <sub>I/O</sub> <sup>(5)</sup>	Input/output capacitance (SDA)	8	pF	V <sub>I/O</sub> = 0V
C <sub>IN</sub> <sup>(5)</sup>	Input capacitance (A0, A1, A2, A3, and SCL)	6	pF	V <sub>IN</sub> = 0V

**POWER-UP TIMING**

Symbol	Parameter	Min.	Typ.	Max.	Unit
t <sub>PUR</sub> <sup>(6)</sup>	Power-up to initiation of read operation			1	ms
t <sub>PUW</sub> <sup>(6)</sup>	Power-up to initiation of write operation			5	ms
t <sub>R</sub> V <sub>CC</sub> <sup>(7)</sup>	V <sub>CC</sub> Power-up ramp rate	0.2		50	V/msec

**POWER-UP AND POWER-DOWN**

There are no restrictions on the power-up or power-down sequencing of the bias supplies V<sub>CC</sub>, V<sub>+</sub>, and V<sub>-</sub> provided that all three supplies reach their final values within 1msec of each other. However, at all times, the voltages on the potentiometer pins must be less than V<sub>+</sub> and more than V<sub>-</sub>. The recall of the wiper position from nonvolatile memory is not in effect until all supplies reach their final value.

- Notes: (5) This parameter is periodically sampled and not 100% tested  
(6) t<sub>PUR</sub> and t<sub>PUW</sub> are the delays required from the time the third (last) power supply (V<sub>CC</sub>, V<sub>+</sub> or V<sub>-</sub>) is stable until the specific instruction can be issued. These parameters are periodically sampled and not 100% tested.  
(7) Sample tested only.

**A.C. TEST CONDITIONS**

Input pulse levels	$V_{CC} \times 0.1$ to $V_{CC} \times 0.9$
Input rise and fall times	10ns
Input and output timing level	$V_{CC} \times 0.5$

**EQUIVALENT A.C. LOAD CIRCUIT**

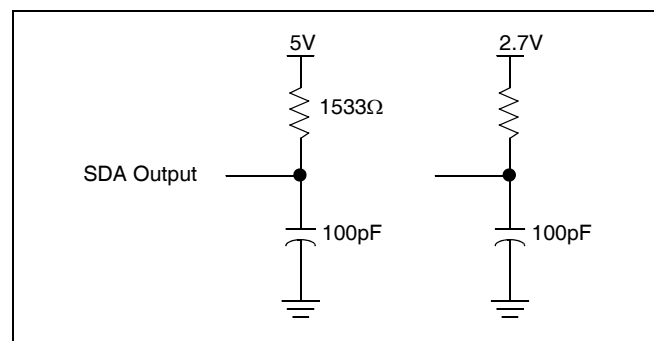

**Circuit #3 SPICE Macro Model**

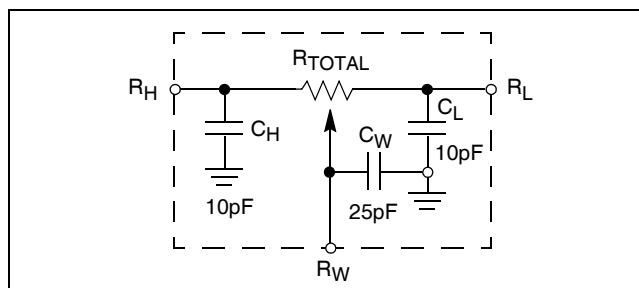

**AC TIMING** (over recommended operating conditions)

Symbol	Parameter	Min.	Max.	Unit
$f_{SCL}$	Clock frequency	100	400	kHz
$t_{CYC}$	Clock cycle time	2500		ns
$t_{HIGH}$	Clock high time	600		ns
$t_{LOW}$	Clock low time	1300		ns
$t_{SU:STA}$	Start setup time	600		ns
$t_{HD:STA}$	Start hold time	600		ns
$t_{SU:STO}$	Stop setup time	600		ns
$t_{SU:DAT}$	SDA data input setup time	100		ns
$t_{HD:DAT}$	SDA data input hold time	30		ns
$t_R$	SCL and SDA rise time		300	ns
$t_F$	SCL and SDA fall time		300	ns
$t_{AA}$	SCL low to SDA data output valid time		900	ns
$t_{DH}$	SDA data output hold time	50		ns
$T_I$	Noise suppression time constant at SCL and SDA inputs	50		ns
$t_{BUF}$	Bus free time (prior to any transmission)	1300		ns
$t_{SU:WPA}$	$\overline{WP}$ , A0, A1, A2 and A3 setup time	0		ns
$t_{HD:WPA}$	$\overline{WP}$ , A0, A1, A2 and A3 hold time	0		ns

### HIGH-VOLTAGE WRITE CYCLE TIMING

Symbol	Parameter	Typ.	Max.	Unit
$t_{WR}$	High-voltage write cycle time (store instructions)	5	10	ms

### XDCP TIMING

Symbol	Parameter	Min.	Max.	Unit
$t_{WRPO}$	Wiper response time after the third (last) power supply is stable		10	$\mu$ s
$t_{WRL}$	Wiper response time after instruction issued (all load instructions)		10	$\mu$ s
$t_{WRID}$	Wiper response time from an active SCL/SCK edge (increment/decrement instruction)		10	$\mu$ s

Note: (8) A device must internally provide a hold time of at least 300ns for the SDA signal in order to bridge the undefined region of the falling edge of SCL.

### TIMING DIAGRAMS

#### START and STOP Timing

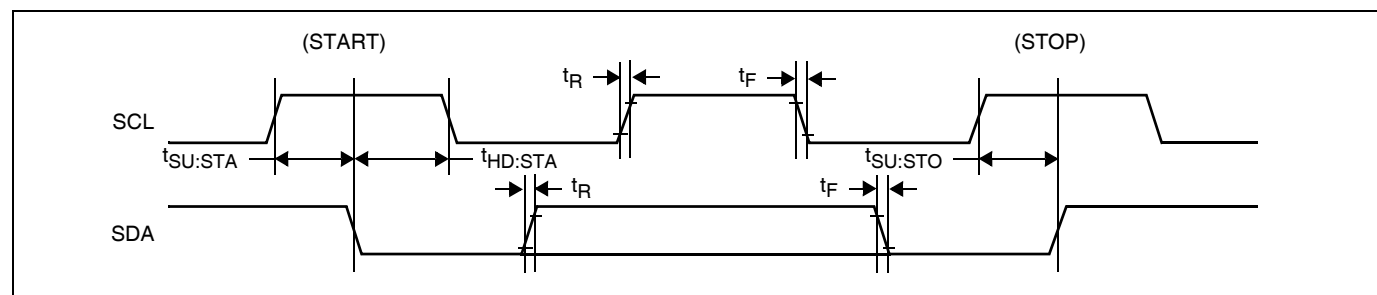

#### Input Timing

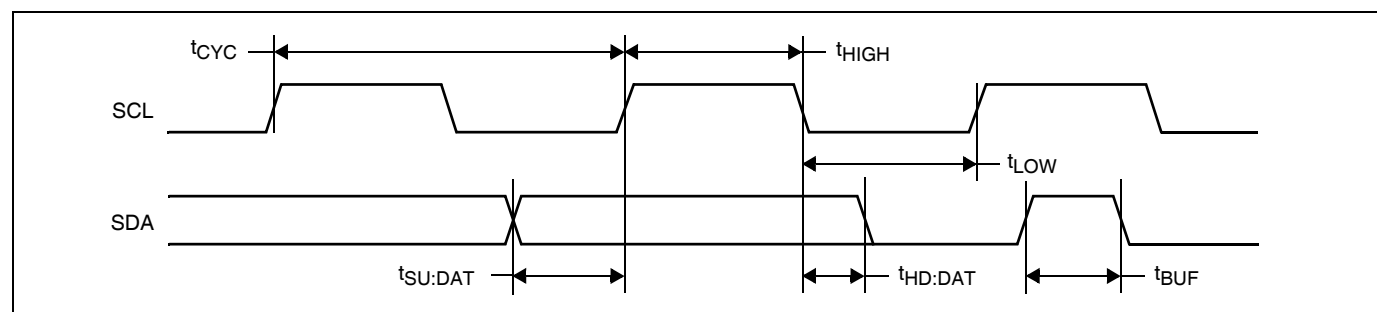

#### Output Timing

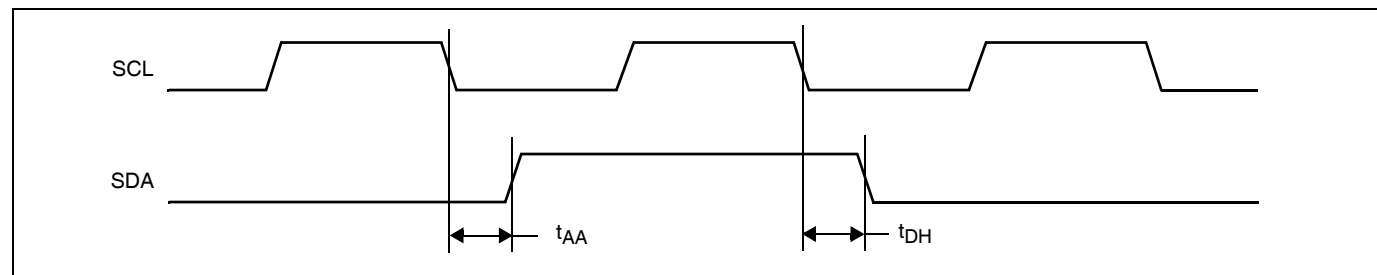



**XDCP Timing (for All Load Instructions)**

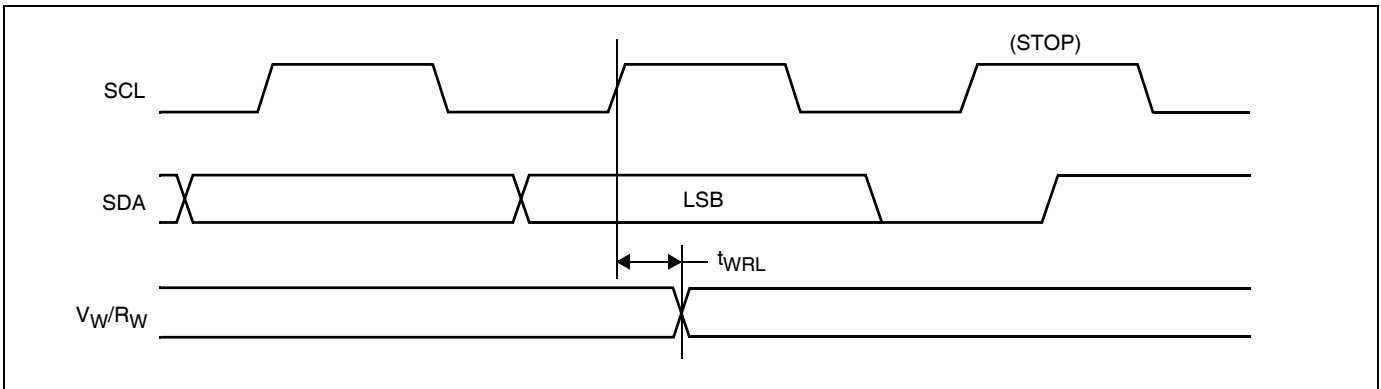

**XDCP Timing (for Increment/Decrement Instruction)**

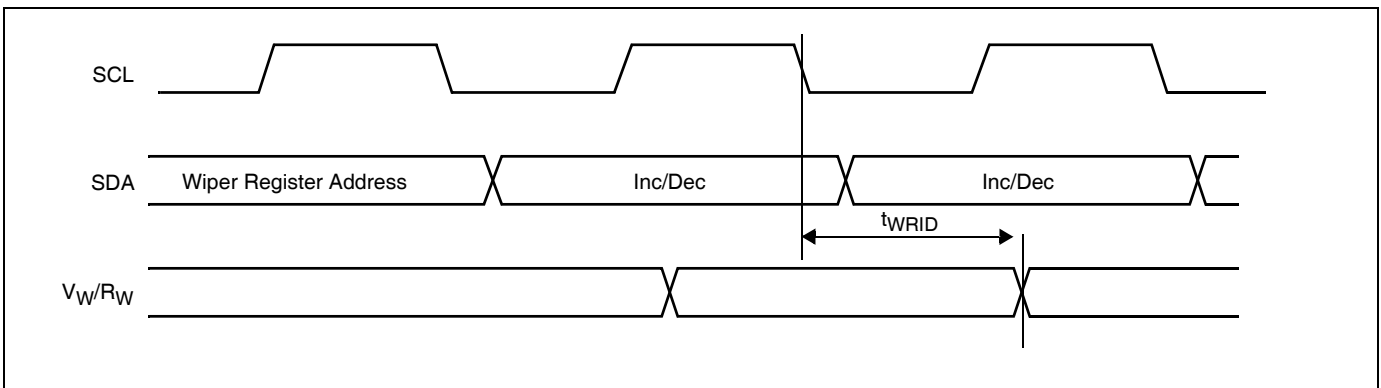

**Write Protect and Device Address Pins Timing**

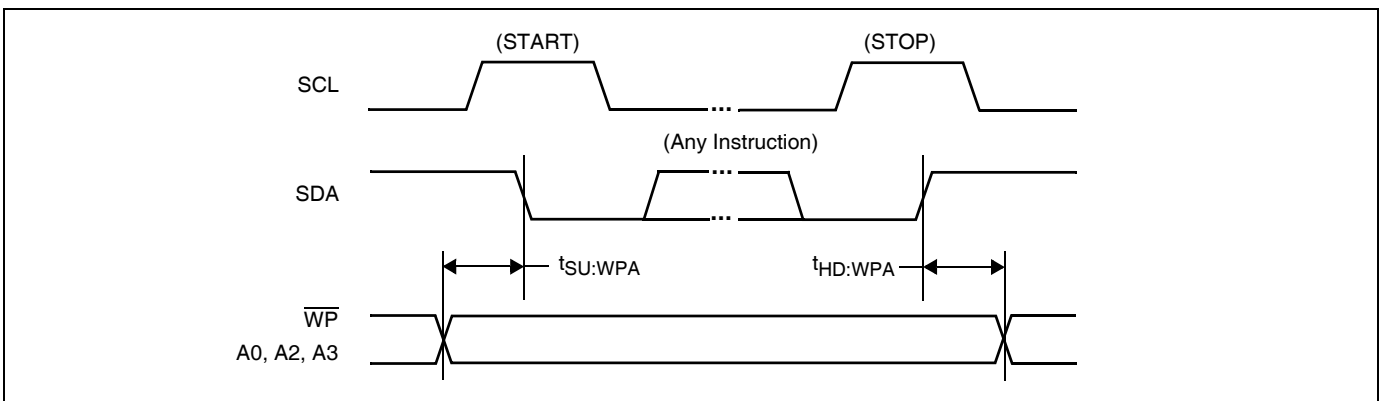

**APPLICATIONS INFORMATION**

**Basic Configurations of Electronic Potentiometers**

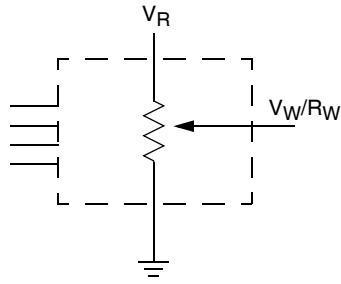

Three terminal Potentiometer;  
Variable voltage divider

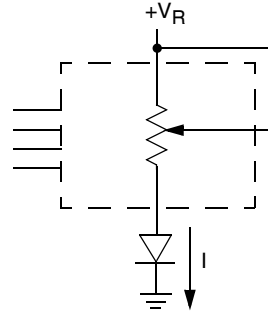

Two terminal Variable Resistor;  
Variable current

**Application Circuits**

**Noninverting Amplifier**

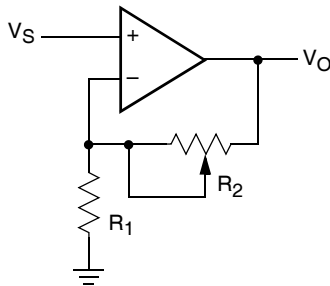

$$V_O = (1 + R_2/R_1)V_S$$

**Voltage Regulator**

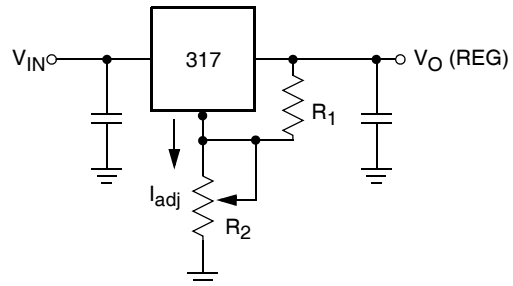

$$V_O (\text{REG}) = 1.25V (1 + R_2/R_1) + I_{\text{adj}} R_2$$

**Offset Voltage Adjustment**

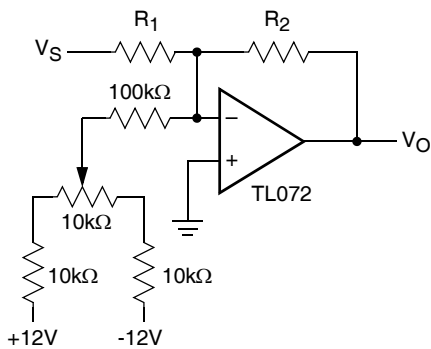

**Comparator with Hysteresis**

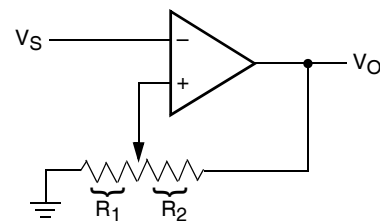

$$V_{UL} = \{R_1/(R_1 + R_2)\} V_O(\text{max})$$

$$V_{LL} = \{R_1/(R_1 + R_2)\} V_O(\text{min})$$

Application Circuits (continued)

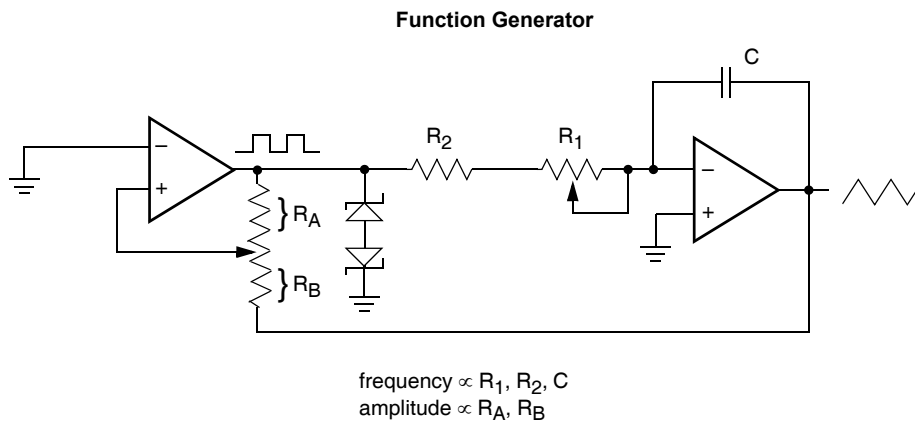
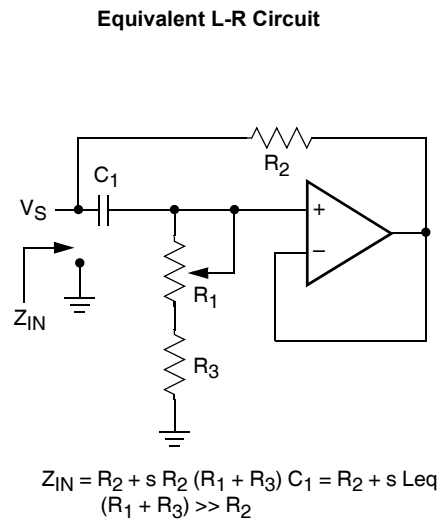
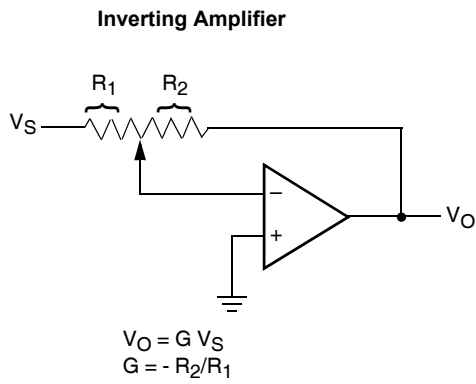
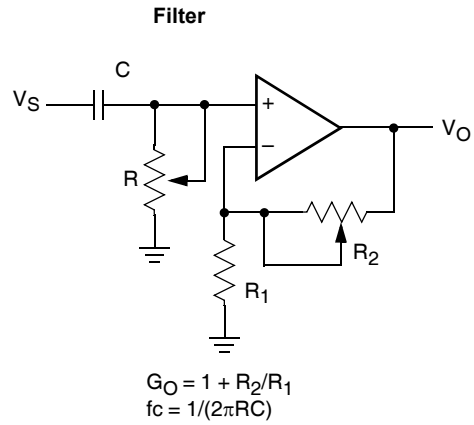
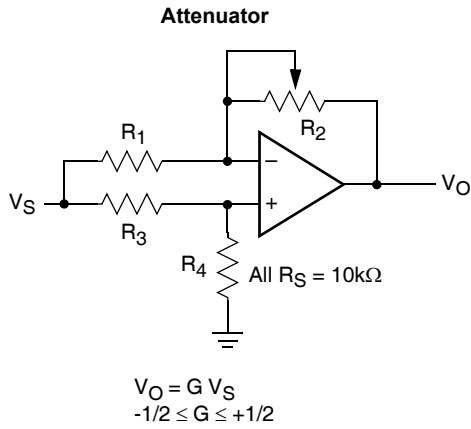

**Thin Shrink Small Outline Plastic Packages (TSSOP)**

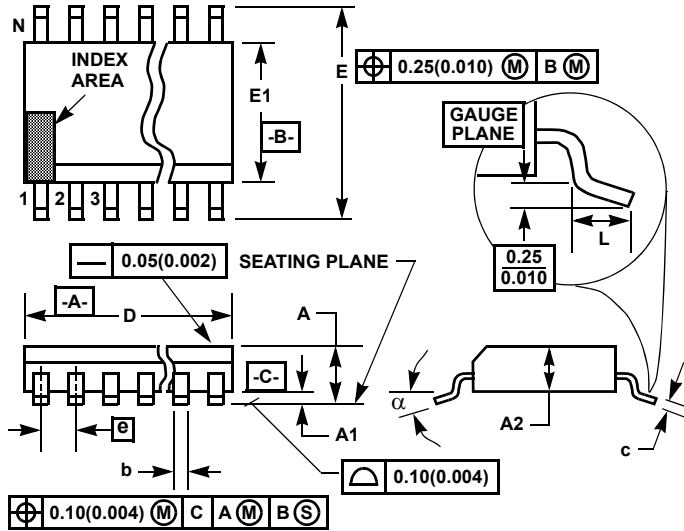

**M14.173**  
**14 LEAD THIN SHRINK SMALL OUTLINE PLASTIC PACKAGE**

SYMBOL	INCHES		MILLIMETERS		NOTES
	MIN	MAX	MIN	MAX	
A	-	0.047	-	1.20	-
A1	0.002	0.006	0.05	0.15	-
A2	0.031	0.041	0.80	1.05	-
b	0.0075	0.0118	0.19	0.30	9
c	0.0035	0.0079	0.09	0.20	-
D	0.195	0.199	4.95	5.05	3
E1	0.169	0.177	4.30	4.50	4
e	0.026 BSC		0.65 BSC		-
E	0.246	0.256	6.25	6.50	-
L	0.0177	0.0295	0.45	0.75	6
N	14		14		7
$\alpha$	0°	8°	0°	8°	-

**NOTES:**

1. These package dimensions are within allowable dimensions of JEDEC MO-153-AC, Issue E.
2. Dimensioning and tolerancing per ANSI Y14.5M-1982.
3. Dimension "D" does not include mold flash, protrusions or gate burrs. Mold flash, protrusion and gate burrs shall not exceed 0.15mm (0.006 inch) per side.
4. Dimension "E1" does not include interlead flash or protrusions. Interlead flash and protrusions shall not exceed 0.15mm (0.006 inch) per side.
5. The chamfer on the body is optional. If it is not present, a visual index feature must be located within the crosshatched area.
6. "L" is the length of terminal for soldering to a substrate.
7. "N" is the number of terminal positions.
8. Terminal numbers are shown for reference only.
9. Dimension "b" does not include dambar protrusion. Allowable dambar protrusion shall be 0.08mm (0.003 inch) total in excess of "b" dimension at maximum material condition. Minimum space between protrusion and adjacent lead is 0.07mm (0.0027 inch).
10. Controlling dimension: MILLIMETER. Converted inch dimensions are not necessarily exact. (Angles in degrees)

Rev. 2 4/06

**Small Outline Plastic Packages (SOIC)**

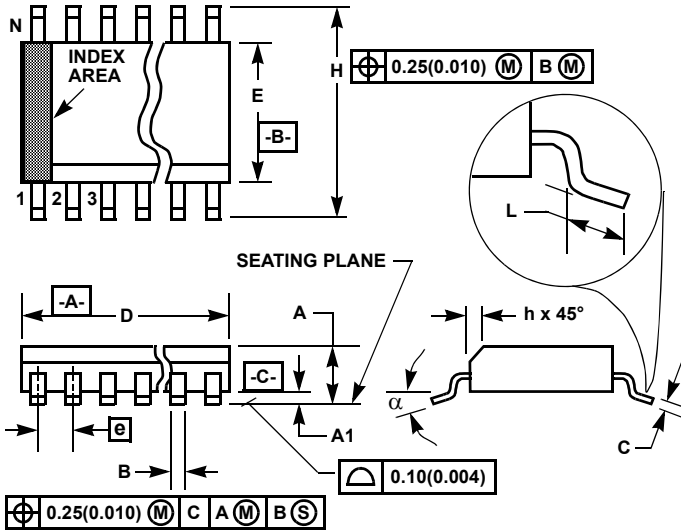

**M16.3 (JEDEC MS-013-AA ISSUE C)  
16 LEAD WIDE BODY SMALL OUTLINE PLASTIC PACKAGE**

SYMBOL	INCHES		MILLIMETERS		NOTES
	MIN	MAX	MIN	MAX	
A	0.0926	0.1043	2.35	2.65	-
A1	0.0040	0.0118	0.10	0.30	-
B	0.013	0.0200	0.33	0.51	9
C	0.0091	0.0125	0.23	0.32	-
D	0.3977	0.4133	10.10	10.50	3
E	0.2914	0.2992	7.40	7.60	4
e	0.050 BSC		1.27 BSC		-
H	0.394	0.419	10.00	10.65	-
h	0.010	0.029	0.25	0.75	5
L	0.016	0.050	0.40	1.27	6
N	16		16		7
$\alpha$	0°	8°	0°	8°	-

**NOTES:**

1. Symbols are defined in the "MO Series Symbol List" in Section 2.2 of Publication Number 95.
2. Dimensioning and tolerancing per ANSI Y14.5M-1982.
3. Dimension "D" does not include mold flash, protrusions or gate burrs. Mold flash, protrusion and gate burrs shall not exceed 0.15mm (0.006 inch) per side.
4. Dimension "E" does not include interlead flash or protrusions. Interlead flash and protrusions shall not exceed 0.25mm (0.010 inch) per side.
5. The chamfer on the body is optional. If it is not present, a visual index feature must be located within the crosshatched area.
6. "L" is the length of terminal for soldering to a substrate.
7. "N" is the number of terminal positions.
8. Terminal numbers are shown for reference only.
9. The lead width "B", as measured 0.36mm (0.014 inch) or greater above the seating plane, shall not exceed a maximum value of 0.61mm (0.024 inch)
10. Controlling dimension: MILLIMETER. Converted inch dimensions are not necessarily exact.

Rev. 1 6/05

© Copyright Intersil Americas LLC 2005-2006. All Rights Reserved.  
All trademarks and registered trademarks are the property of their respective owners.

For additional products, see [www.intersil.com/en/products.html](http://www.intersil.com/en/products.html)

Intersil products are manufactured, assembled and tested utilizing ISO9001 quality systems as noted in the quality certifications found at [www.intersil.com/en/support/qualandreliability.html](http://www.intersil.com/en/support/qualandreliability.html)

Intersil products are sold by description only. Intersil may modify the circuit design and/or specifications of products at any time without notice, provided that such modification does not, in Intersil's sole judgment, affect the form, fit or function of the product. Accordingly, the reader is cautioned to verify that datasheets are current before placing orders. Information furnished by Intersil is believed to be accurate and reliable. However, no responsibility is assumed by Intersil or its subsidiaries for its use; nor for any infringements of patents or other rights of third parties which may result from its use. No license is granted by implication or otherwise under any patent or patent rights of Intersil or its subsidiaries.

For information regarding Intersil Corporation and its products, see [www.intersil.com](http://www.intersil.com)