

### FEATURES

- Single 100-position taper potentiometer
- Nonvolatile (NV) on-demand wiper storage
- Operates from 3V or 5V supplies
- Up/down, increment-controlled interface
- Available in 8-pin (300mil) DIP, 8-pin (150mil) SO, 8-pin (118mil)  $\mu$ SOP, and flip-chip packages
- Operating Temperature:
  - Industrial:  $-40^{\circ}\text{C}$  to  $+85^{\circ}\text{C}$
- Standard Resistance Values:
  - DS1804-010 10k $\Omega$
  - DS1804-050 50k $\Omega$
  - DS1804-100 100k $\Omega$

### PIN ASSIGNMENT

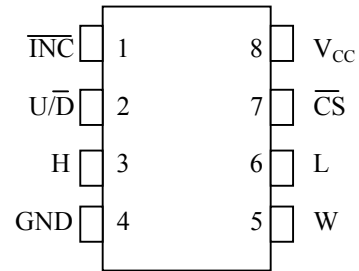

8-Pin DIP (300mil)

8-Pin SO (150mil)

8-Pin  $\mu$ SOP (118mil)

8-Pin Flip-Chip Package

See Mech. Drawings Section

### PIN DESCRIPTION

- H - High-Terminal of Potentiometer
- L - Low-Terminal of Potentiometer
- W - Wiper of Potentiometer
- V<sub>CC</sub> - 3V or 5V Power Supply
- $\overline{\text{CS}}$  - Chip Select
- U/ $\overline{\text{D}}$  - Up/Down Control
- $\overline{\text{INC}}$  - Increment/Decrement Wiper Control
- GND - Ground

### DESCRIPTION

The DS1804 NV trimmer potentiometer is a nonvolatile digital potentiometer that has 100 positions. The device provides an ideal method for low-cost trimming applications using a CPU or manual control input with minimal external circuitry. Wiper position of the DS1804 can be stored in EEPROM memory on demand. The device's wiper position is manipulated by a three-terminal port that provides an increment/decrement counter controlled interface. This port consists of the control inputs  $\overline{\text{CS}}$ ,  $\overline{\text{INC}}$ , and U/ $\overline{\text{D}}$ . The DS1804 is available in three resistor grades, which include a 10k $\Omega$ , 50k $\Omega$ , and 100k $\Omega$ . The device is provided in an industrial temperature grade. Additionally, the DS1804 will operate from 3V or 5V supplies and is ideal for portable application requirements. Three packaging options are available and include the 8-pin (300mil) DIP, 8-pin (150mil) SO, 8-pin (118mil)  $\mu$ SOP, and the flip-chip package.

## OPERATION

The DS1804 is a single nonvolatile potentiometer. The device has a total of 100 tap-points including the L- and H- terminals. A total of 99 resistive segments exist between the L- and H- terminals. These tap-points are accessible to the W-terminal, whose position is controlled via a three-terminal control port. A block diagram of the DS1804 is shown in Figure 1.

The three-terminal port of the DS1804 provides an increment/decrement interface which is activated via a chip-select input. This interface consists of the input signals  $\overline{CS}$ ,  $\overline{INC}$ , and  $U/\overline{D}$ . These input signals control a 7-bit up/down counter. The output of the 7-bit up/down counter controls a 1 of 100 decoder to select wiper position. Additionally, this interface provides for a wiper storage operation using the  $\overline{CS}$  and  $\overline{INC}$  input control pins. The timing diagram for the three-terminal interface control is shown in Figure 2.

## PIN DESCRIPTIONS

**V<sub>CC</sub>** - Power Supply. The DS1804 will support supply voltages ranging from +2.7V to +5.5V.

**GND** - Ground.

**H** - High-Terminal Potentiometer. This is the high terminal of the potentiometer. It is not required that this terminal be connected to a potential greater than the L-terminal. Voltage applied to the H-terminal cannot exceed the power-supply voltage,  $V_{CC}$ , or go below ground.

**L** - Low-Terminal Potentiometer. This is the low terminal of the potentiometer. It is not required that this terminal be connected to a potential less than the H-terminal. Voltage applied to the L-terminal cannot exceed the power-supply voltage,  $V_{CC}$ , or go below ground.

**W** - Wiper of the Potentiometer. This pin is the wiper of the potentiometer. Its position on the resistor array is controlled by the three-terminal control port. Voltage applied to the wiper cannot exceed the power-supply voltage,  $V_{CC}$ , or go below ground.

$\overline{CS}$  - Chip Select. The  $\overline{CS}$  input is used to activate the control port of the DS1804. This input is active low. When in a high-state, activity on the  $\overline{INC}$  and  $U/\overline{D}$  port pins will not affect or change wiper position.

$\overline{INC}$  - Wiper Movement Control. This input provides for wiper position changes when the  $\overline{CS}$  pin is low. Wiper position changes of the W-terminal will occur one position per high-to-low transition of this input signal. Position changes will not occur if the  $\overline{CS}$  pin is in a high state.

$U/\overline{D}$  - Up/Down Control. This input sets the direction of wiper movement. When in a high state and  $\overline{CS}$  is low, any high-to-low transition on  $\overline{INC}$  will cause a one position movement of the wiper towards the H-terminal. When in a low state and  $\overline{CS}$  is low, any high-to-low transitions on  $\overline{INC}$  will cause the position of the wiper to move towards the L-terminal.

## DS1804 BLOCK DIAGRAM Figure 1

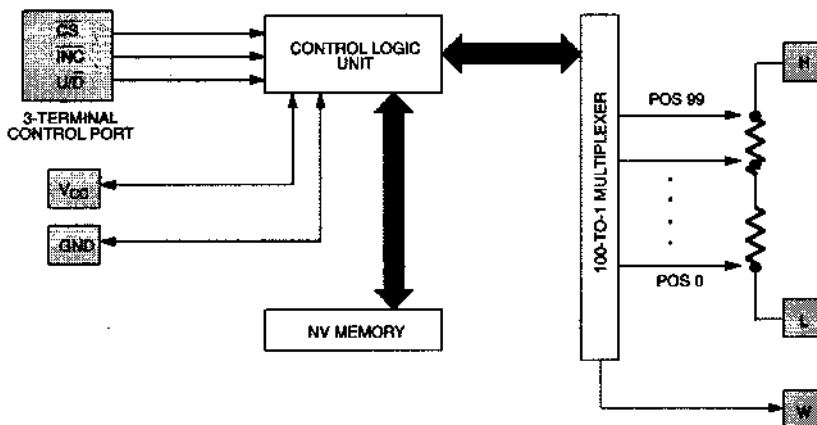

### POWER-UP/POWER-DOWN CONDITIONS

On power-up, the DS1804 will load the value of EEPROM memory into the wiper position register (or 1 of 100 decoder). The value of this register can then be set to another wiper position if desired, by using the three-terminal control port. On power-up, wiper position will be loaded within a maximum time period of 500 $\mu$ s once the power-supply is stable. Additionally, the three-terminal interface port will be active after 50ms.

On power-down, the wiper position register data will be lost. On the next device power-up, the value of EEPROM memory will be loaded into the wiper position register.

On shipment from the factory, Dallas Semiconductor does not guarantee a specified EEPROM memory value. This value should be set by the customer as needed.

### NONVOLATILE WIPER STORAGE

Wiper position of the DS1804 can be stored using the  $\overline{\text{INC}}$  and  $\overline{\text{CS}}$  inputs. Storage of the wiper position takes place whenever the  $\overline{\text{CS}}$  input transitions from low-to-high while the  $\overline{\text{INC}}$  is high. Once this condition has occurred the value of the current wiper position will be written to EEPROM memory.

The DS1804 is specified to accept 50,000 writes to EEPROM before a wear-out condition. After wear-out the DS1804 will still function and wiper position can be changed during powered conditions using the three-terminal control port. However, on power-up the wiper-position will be indeterminate.

### ONE-TIME PROGRAMMABILITY (OTP)

The DS1804 can be easily used as an OTP device. The user of the DS1804 can trim the desired value of the wiper position and set this position for storage as described above. Any activity through the three-terminal port can then be prevented by connecting the  $\overline{\text{CS}}$  input pin to  $V_{\text{CC}}$ . Also, an OTP application does not adversely affect the number of times EEPROM is written, since EEPROM will only be loaded and *not written* during a power-up or power-down condition.

On power-up, the DS1804 will load the current value of EEPROM memory into the wiper position register.

**ABSOLUTE MAXIMUM RATINGS\***

Voltage on Any Pin Relative to Ground	-1.0V to +7.0V
Operating Temperature Range	-40°C to +85°C
Storage Temperature Range	-55°C to +125°C
Soldering Temperature	See IPC/JEDEC J-STD-020A Specification

\* This is a stress rating only and functional operation of the device at these or any other conditions above those indicated in the operation sections of this specification is not implied. Exposure to absolute maximum rating conditions for extended periods of time may affect reliability.

## 1) Insert A (Burn-in Disclaimer)

The Dallas Semiconductor DS1804 is built to the highest quality standards and manufactured for long term reliability. All Dallas Semiconductor devices are made using the same quality materials and manufacturing methods. However, the flip-chip package version of the DS1804 is not exposed to environmental stresses, such as burn-in, that some industrial applications require. For specific reliability information on this product, please contact the factory in Dallas at 972-371-4448.

**RECOMMENDED DC OPERATING CONDITIONS** (-40°C to +85°C)

PARAMETER	SYMBOL	MIN	TYP	MAX	UNITS	NOTES
Supply Voltage	V <sub>CC</sub>	+2.7		5.5	V	1
Input Logic 1	V <sub>IH</sub>	2.0		V <sub>CC</sub> + 0.5	V	1,2
Input Logic 0	V <sub>IL</sub>	-0.5		+0.8 +0.6	V	1,15
Resistor Inputs	L,H,W	GND - 0.5		V <sub>CC</sub> + 0.5	V	1,3

**DC ELECTRICAL CHARACTERISTICS** (-40°C to +85°C; V<sub>CC</sub> = 2.7V to 5.5V)

PARAMETER	SYMBOL	MIN	TYP	MAX	UNITS	NOTES
Supply Current	I <sub>CC</sub>			400	μA	4
Input Leakage	I <sub>LI</sub>	-1		+1	μA	
Wiper Resistance	R <sub>W</sub>		400	1000	Ω	
Wiper Current	I <sub>W</sub>			1	mA	
Standby Current: 3 Volts 5 Volts	I <sub>STBY</sub>		10 20	48	μA μA	5
Wiper Load Time	t <sub>WLT</sub>		500		μs	6
Power-Up Time	t <sub>PU</sub>		50		ms	14

**ANALOG RESISTOR CHARACTERISTICS** (-40°C to +85°C;  $V_{CC}$  = 2.7V to 5.5V)

PARAMETER	SYMBOL	MIN	TYP	MAX	UNITS	NOTES
End-to-End Resistor Tolerance		-20		+20	%	8
Absolute Linearity			±0.6		LSB	9
Relative Linearity			±0.25		LSB	10
-3dB Cutoff Frequency	$f_{\text{cutoff}}$				MHz	11
Temperature Coefficient			750		ppm/°C	

**CAPACITANCE** (25°C;  $V_{CC}$  = 2.7V to 5.5V)

PARAMETER	SYMBOL	MIN	TYP	MAX	UNITS	NOTES
Input Capacitance	$C_{\text{IN}}$			5	pF	12
Output Capacitance	$C_{\text{OUT}}$			7	pF	12

**AC ELECTRICAL CHARACTERISTICS** (-40°C to +85°C;  $V_{CC}$  = 2.7V to 5.5V)

PARAMETER	SYMBOL	MIN	TYP	MAX	UNITS	NOTES
$\overline{\text{CS}}$ to $\overline{\text{INC}}$ Setup	$t_{\text{CI}}$	50			ns	13
$\text{U}/\overline{\text{D}}$ to $\overline{\text{INC}}$ Setup	$t_{\text{DI}}$	100			ns	13
$\overline{\text{INC}}$ Low Period	$t_{\text{IL}}$	50			ns	13
$\overline{\text{INC}}$ High Period	$t_{\text{IH}}$	100			ns	13
$\overline{\text{INC}}$ inactive to $\overline{\text{CS}}$ Inactive	$t_{\text{IC}}$	500			ns	13
$\overline{\text{CS}}$ Deselect Time	$t_{\text{CPH}}$	100			ns	13
Wiper Change to $\overline{\text{INC}}$ Low	$t_{\text{IW}}$			200	ns	13
$\overline{\text{INC}}$ Rise and Fall Times	$t_{\text{R}}, t_{\text{F}}$			500	μs	13
$\overline{\text{INC}}$ Low to $\overline{\text{CS}}$ Inactive	$t_{\text{IK}}$	50			ns	16
Wiper Storage Time	$t_{\text{WST}}$			10	ms	13, 17

**NOTES:**

- 1) All voltages are referenced to ground.
- 2) Valid for  $V_{CC} = 5V$  only.
- 3) Resistor input voltages cannot go below ground or exceed  $V_{CC}$  by the amounts as shown in the table.
- 4) Maximum current specifications are based on the clock rate of  $\overline{INC}$  input. This specification represents the current required when changing the wiper position.
- 5) Standby current levels apply when all inputs are driven to appropriate supply levels.  $\overline{CS}$ ,  $\overline{INC}$ ,  $U/\overline{D} = V_{CC}$ .
- 6) Wiper load time is specified as the time required for the DS1804 to load the wiper position with the contents of nonvolatile memory once  $V_{CC}$  has reached a stable operating voltage equal to or greater than 2.7V.
- 7) The DS1804 is available in three resistor values. These include the DS1804-010, 10k $\Omega$ ; the DS1804-050, 50k $\Omega$ ; and the DS1804-100, 100k $\Omega$ .
- 8) Valid at 25°C only.
- 9) Absolute linearity is used to compare measured wiper voltage versus expected wiper voltage as determined by wiper position. The DS1804 is specified to provide an absolute linearity of  $\pm 0.60$  LSB.
- 10) Relative linearity is used to determine the change in voltage between successive tap positions. The DS1804 is specified to provide a relative linearity specification of  $\pm 0.25$  LSB.
- 11) -3dB cutoff frequency characteristics for the DS1804 depend on potentiometer total resistance. DS1804-010, 1MHz; DS1804-050, 200 kHz; and DS1804-100, 100 kHz.
- 12) Capacitance values apply at 25°C.
- 13) See Figure 2.
- 14) Power-up time is specified as the time required before the three-terminal control becomes active after a stable power supply level has been reached.
- 15) At  $V_{CC} = 2.7V$ ,  $V_{IL} = 0.8V$ .
- 16) The  $\overline{INC}$  low to  $\overline{CS}$  inactive is specified to be 50ns minimum. This is the transition condition which allows the DS1804 three-terminal port to become inactive without writing the EEPROM memory of the part.
- 17) Wiper Storage Time,  $t_{WST}$ , is the time required for the DS1804 to write EEPROM memory for storage of a new wiper position. The maximum time required to accomplish this task is specified at 10ms.

## THREE-TERMINAL INTERFACE TIMING DIAGRAM Figure 2

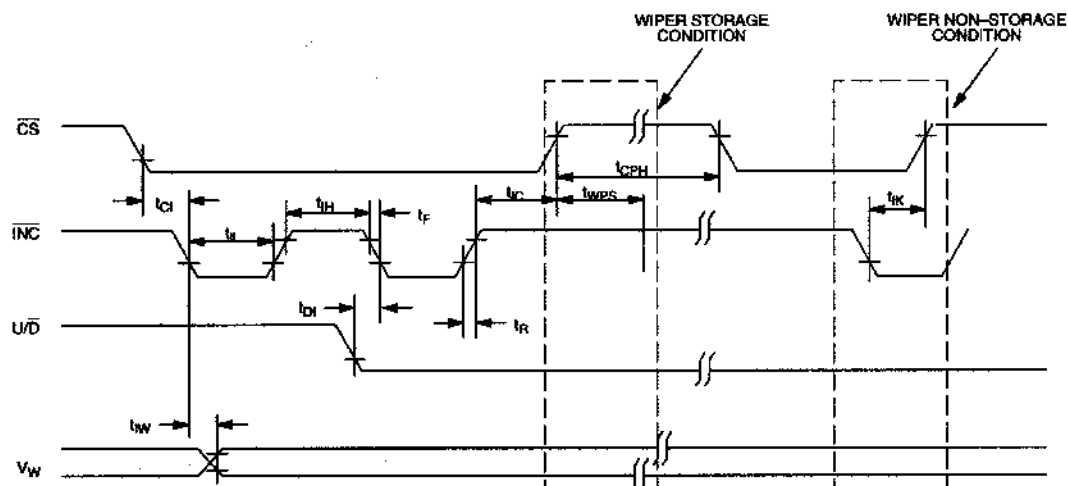

## DS1804 ORDERING INFORMATION

ORDERING NUMBER	PACKAGE	OPERATING TEMPERATURE	VERSION
DS1804-010	8L DIP (300MIL)	-40°C TO +85°C	10kΩ
DS1804-050	8L DIP (300MIL)	-40°C TO +85°C	50kΩ
DS1804-100	8L DIP (300MIL)	-40°C TO +85°C	100kΩ
DS1804Z-010	8L SOIC (150MIL)	-40°C TO +85°C	10kΩ
DS1804Z-050	8L SOIC (150MIL)	-40°C TO +85°C	50kΩ
DS1804Z-100	8L SOIC (150MIL)	-40°C TO +85°C	100kΩ
DS1804U-010	8L μSOP (118MIL)	-40°C TO +85°C	10kΩ
DS1804U-050	8L μSOP (118MIL)	-40°C TO +85°C	50kΩ
DS1804U-100	8L μSOP (118MIL)	-40°C TO +85°C	100kΩ
DS1804X-010	8L FCP (118MIL)	-40°C TO +85°C	10kΩ
DS1804X-050	8L FCP (118MIL)	-40°C TO +85°C	50kΩ
DS1804X-100	8L FCP (118MIL)	-40°C TO +85°C	100kΩ

## BRANDING INFORMATION Figure 3

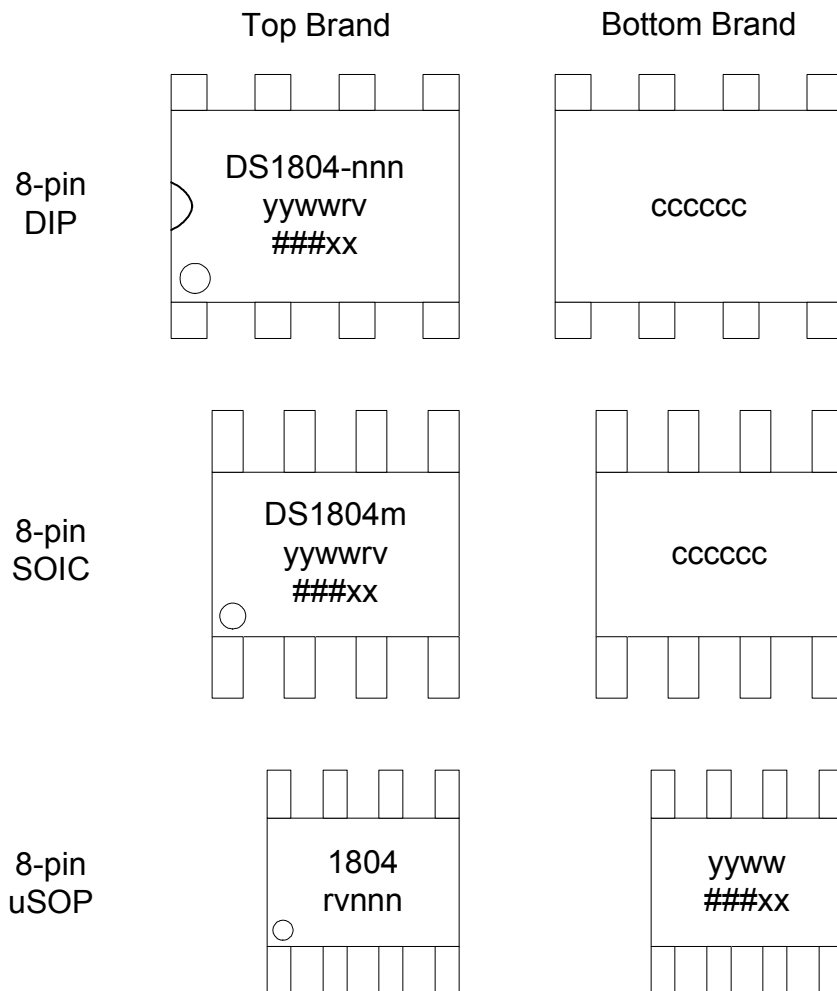

DS1804 Brand Codes		
Code	Description	Values
nnn	Pot Size (DIP/uSOP)	010 10k ohm 050 50k ohm 100 100k ohm
m	Pot Size (SOIC)	X 10k ohm L 50k ohm C 100k ohm
yyww	Date Code. It identifies the year and work week the device was assembled	eg. 0035 is the 35th work week of 2000
rv	Die Revision	Generally this is a letter followed by a number (eg. B2)
###xx	Lot Code	
ccccc	Country of Assembly	



## [DS1804](#)

### Part Number Table

Notes:

1. See the [DS1804 QuickView Data Sheet](#) for further information on this product family or download the [DS1804 full data sheet](#) (PDF, 192kB).
2. Other options and links for purchasing parts are listed at: <http://www.maxim-ic.com/sales>.
3. [Didn't Find What You Need?](#) Ask our applications engineers. Expert assistance in finding parts, usually within one business day.
4. Part number suffixes: T or T&R = tape and reel; + = RoHS/lead-free; # = RoHS/lead-exempt. More: See [full data sheet](#) or [Part Naming Conventions](#).
5. \* Some packages have variations, listed on the drawing. "PkgCode/Variation" tells which variation the product uses.

Part Number	Notes	Free Sample	Buy Direct	Package: TYPE PINS SIZE DRAWING CODE/VAR *	Temp	RoHS/Lead-Free? Materials Analysis
DS1804X-050/T&R	50kohms			FCHIP;15 pin;67 Dwg: <a href="#">56-G7013-001A</a> (PDF) Use pkgcode/variation: BF1522-1*	-40C to +85C	RoHS/Lead-Free: <a href="#">No</a>
DS1804X-100/T&R	100kohms			FCHIP;15 pin;67 Dwg: <a href="#">56-G7013-001A</a> (PDF) Use pkgcode/variation: BF1522-1*	-40C to +85C	RoHS/Lead-Free: <a href="#">No</a>
DS1804X-010/T&R	10kohms			FCHIP;15 pin;67 Dwg: <a href="#">56-G7013-001A</a> (PDF) Use pkgcode/variation: BF1522-1*	-40C to +85C	RoHS/Lead-Free: <a href="#">No</a>
DS1804-050+				PDIP;8 pin;300 Dwg: <a href="#">56-G5005-000A</a> (PDF) Use pkgcode/variation: P8+7*	-40C to +85C	RoHS/Lead-Free: <a href="#">Yes</a> <a href="#">Materials Analysis</a>

DS1804-100	100kohms	PDIP;8 pin;300 Dwg: <a href="#">56-G5005-000A</a> (PDF) Use pkgcode/variation: P8-7*	-40C to +85C RoHS/Lead-Free: <a href="#">No Materials Analysis</a>
DS1804-050	50kohms	PDIP;8 pin;300 Dwg: <a href="#">56-G5005-000A</a> (PDF) Use pkgcode/variation: P8-7*	-40C to +85C RoHS/Lead-Free: <a href="#">No Materials Analysis</a>
DS1804-010	10kohms	PDIP;8 pin;300 Dwg: <a href="#">56-G5005-000A</a> (PDF) Use pkgcode/variation: P8-7*	-40C to +85C RoHS/Lead-Free: <a href="#">No Materials Analysis</a>
DS1804-010+		PDIP;8 pin;300 Dwg: <a href="#">56-G5005-000A</a> (PDF) Use pkgcode/variation: P8+7*	-40C to +85C RoHS/Lead-Free: <a href="#">Yes Materials Analysis</a>
DS1804-100+		PDIP;8 pin;300 Dwg: <a href="#">56-G5005-000A</a> (PDF) Use pkgcode/variation: P8+7*	-40C to +85C RoHS/Lead-Free: <a href="#">Yes Materials Analysis</a>
DS1804Z-100+T&R	100kohms	SOIC;8 pin;150 Dwg: <a href="#">56-G2008-001C</a> (PDF) Use pkgcode/variation: S8+2*	-40C to +85C RoHS/Lead-Free: <a href="#">Yes Materials Analysis</a>
DS1804Z-010+T&R	10kohms	SOIC;8 pin;150 Dwg: <a href="#">56-G2008-001C</a> (PDF) Use pkgcode/variation: S8+2*	-40C to +85C RoHS/Lead-Free: <a href="#">Yes Materials Analysis</a>
DS1804Z-050+	50kohms	SOIC;8 pin;150 Dwg: <a href="#">56-G2008-001C</a> (PDF) Use pkgcode/variation: S8+2*	-40C to +85C RoHS/Lead-Free: <a href="#">Yes Materials Analysis</a>
DS1804Z-100	100kohms	SOIC;8 pin;150 Dwg: <a href="#">56-G2008-001C</a> (PDF) Use pkgcode/variation: S8-2*	-40C to +85C RoHS/Lead-Free: <a href="#">No Materials Analysis</a>
DS1804Z-050	50kohms	SOIC;8 pin;150 Dwg: <a href="#">56-G2008-001C</a> (PDF) Use pkgcode/variation: S8-2*	-40C to +85C RoHS/Lead-Free: <a href="#">No Materials Analysis</a>
DS1804Z-010	10kohms	SOIC;8 pin;150 Dwg: <a href="#">56-G2008-001C</a> (PDF) Use pkgcode/variation: S8-2*	-40C to +85C RoHS/Lead-Free: <a href="#">No Materials Analysis</a>

DS1804Z-050+T&R		SOIC;8 pin;150 Dwg: <a href="#">56-G2008-001C</a> (PDF) Use pkgcode/variation: S8+2*	-40C to +85C RoHS/Lead-Free: <a href="#">Yes</a> <a href="#">Materials Analysis</a>
DS1804Z-100+		SOIC;8 pin;150 Dwg: <a href="#">56-G2008-001C</a> (PDF) Use pkgcode/variation: S8+2*	-40C to +85C RoHS/Lead-Free: <a href="#">Yes</a> <a href="#">Materials Analysis</a>
DS1804Z-010+	10kohms	SOIC;8 pin;150 Dwg: <a href="#">56-G2008-001C</a> (PDF) Use pkgcode/variation: S8+2*	-40C to +85C RoHS/Lead-Free: <a href="#">Yes</a> <a href="#">Materials Analysis</a>
DS1804Z-100/T&R	100kohms	SOIC;8 pin;150 Dwg: <a href="#">56-G2008-001C</a> (PDF) Use pkgcode/variation: S8-2*	-40C to +85C RoHS/Lead-Free: <a href="#">No</a> <a href="#">Materials Analysis</a>
DS1804Z-050/T&R	50kohms	SOIC;8 pin;150 Dwg: <a href="#">56-G2008-001C</a> (PDF) Use pkgcode/variation: S8-2*	-40C to +85C RoHS/Lead-Free: <a href="#">No</a> <a href="#">Materials Analysis</a>
DS1804Z-010/T&R	10kohms	SOIC;8 pin;150 Dwg: <a href="#">56-G2008-001C</a> (PDF) Use pkgcode/variation: S8-2*	-40C to +85C RoHS/Lead-Free: <a href="#">No</a> <a href="#">Materials Analysis</a>
DS1804UR-050/T&R/		uSOP;8 pin;118 Dwg: <a href="#">21-0036J</a> (PDF) Use pkgcode/variation: U8-1*	-40C to +85C RoHS/Lead-Free: <a href="#">No</a> <a href="#">Materials Analysis</a>
DS1804U-100	100kohms	uSOP;8 pin;118 Dwg: <a href="#">21-0036J</a> (PDF) Use pkgcode/variation: U8-3*	-40C to +85C RoHS/Lead-Free: <a href="#">No</a> <a href="#">Materials Analysis</a>
DS1804U-100+T&R	100kohms	uSOP;8 pin;118 Dwg: <a href="#">21-0036J</a> (PDF) Use pkgcode/variation: U8+1*	-40C to +85C RoHS/Lead-Free: <a href="#">Yes</a> <a href="#">Materials Analysis</a>
DS1804U-050+		uSOP;8 pin;118 Dwg: <a href="#">21-0036J</a> (PDF) Use pkgcode/variation: U8+3*	-40C to +85C RoHS/Lead-Free: <a href="#">Yes</a> <a href="#">Materials Analysis</a>
DS1804U-010+T&R		uSOP;8 pin;118 Dwg: <a href="#">21-0036J</a> (PDF) Use pkgcode/variation: U8+3*	-40C to +85C RoHS/Lead-Free: <a href="#">Yes</a> <a href="#">Materials Analysis</a>

DS1804U-010/T&R	10kohms	uSOP;8 pin;118 Dwg: <a href="#">21-0036J</a> (PDF) Use pkgcode/variation: U8-3*	-40C to +85C RoHS/Lead-Free: <a href="#">No Materials Analysis</a>
DS1804U-050+T&R		uSOP;8 pin;118 Dwg: <a href="#">21-0036J</a> (PDF) Use pkgcode/variation: U8+3*	-40C to +85C RoHS/Lead-Free: <a href="#">Yes Materials Analysis</a>
DS1804U-050/T&R	50kohms	uSOP;8 pin;118 Dwg: <a href="#">21-0036J</a> (PDF) Use pkgcode/variation: U8-3*	-40C to +85C RoHS/Lead-Free: <a href="#">No Materials Analysis</a>
DS1804U-100/T&R	100kohms	uSOP;8 pin;118 Dwg: <a href="#">21-0036J</a> (PDF) Use pkgcode/variation: U8-3*	-40C to +85C RoHS/Lead-Free: <a href="#">No Materials Analysis</a>
DS1804UR-050		uSOP;8 pin;118 Dwg: <a href="#">21-0036J</a> (PDF) Use pkgcode/variation: U8-1*	-40C to +85C RoHS/Lead-Free: <a href="#">No Materials Analysis</a>
DS1804U-010	10kohms	uSOP;8 pin;118 Dwg: <a href="#">21-0036J</a> (PDF) Use pkgcode/variation: U8-3*	-40C to +85C RoHS/Lead-Free: <a href="#">No Materials Analysis</a>
DS1804U-010+	10kohms	uSOP;8 pin;118 Dwg: <a href="#">21-0036J</a> (PDF) Use pkgcode/variation: U8+3*	-40C to +85C RoHS/Lead-Free: <a href="#">Yes Materials Analysis</a>
DS1804U-050	50kohms	uSOP;8 pin;118 Dwg: <a href="#">21-0036J</a> (PDF) Use pkgcode/variation: U8-3*	-40C to +85C RoHS/Lead-Free: <a href="#">No Materials Analysis</a>
DS1804U-100+		uSOP;8 pin;118 Dwg: <a href="#">21-0036J</a> (PDF) Use pkgcode/variation: U8+1*	-40C to +85C RoHS/Lead-Free: <a href="#">Yes Materials Analysis</a>

[Didn't Find What You Need?](#)

[CONTACT US: SEND US AN EMAIL](#)