



Terminal Voltage $\pm 5V$, 32 Taps

X9511

Single Digitally-Controlled (XDCP™) Potentiometer (Push Button Controlled)

FEATURES

- Push button controlled
- Low power CMOS
 - Active current, 3mA max
 - Standby current, 200 μ A max
- 31 resistive elements
 - Temperature compensated
 - $\pm 20\%$ end to end resistance range
 - $-5V$ to $+5V$ range
- 32 wiper tap points
 - Wiper positioned via two push button inputs
 - Slow & fast scan modes
 - AUTOSTORE® option
 - Manual store option
 - Wiper position stored in nonvolatile memory and recalled on power-up
- 100 year wiper position data retention
- X9511W = 10K Ω
- Packages
 - 8-lead PDIP
 - 8-lead SOIC

DESCRIPTION

The Xicor X9511 is a push button controlled potentiometer that is ideal for push button controlled resistance trimming.

The X9511 is a resistor array composed of 31 resistive elements. Between each element and at either end are tap points accessible to the wiper element. The position of the wiper element is controlled by the PU and PD inputs. The position of the wiper can be automatically stored in E² memory and then be recalled upon a subsequent power-on operation.

The resolution of the X9511 is equal to the maximum resistance value divided by 31. As an example, for the X9511W (10K Ω) each tap point represents 323 Ω .

All Xicor nonvolatile products are designed and tested for applications requiring extended endurance and data retention.

BLOCK DIAGRAM

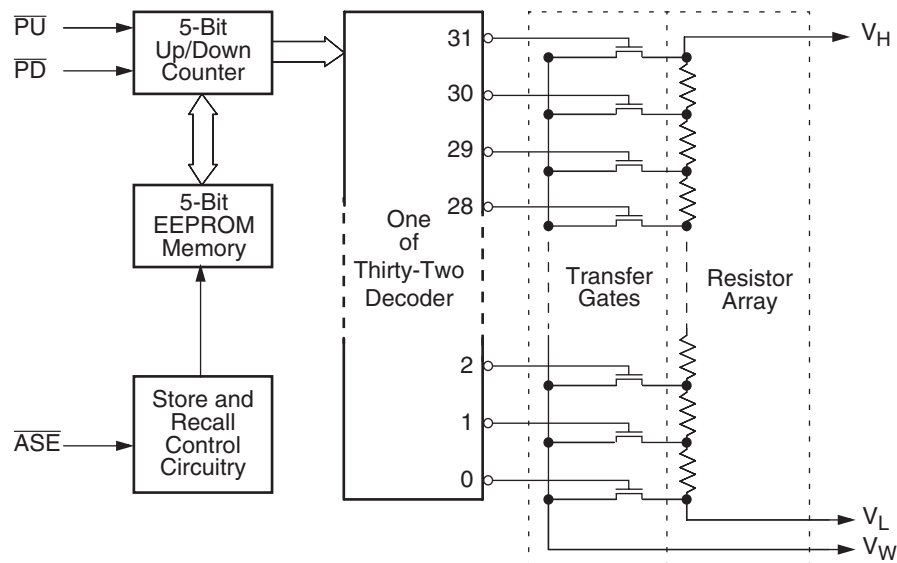

X9511

PIN DESCRIPTIONS

V_H/R_H and V_L/R_L

The high (V_H/R_H) and low (V_L/R_L) terminals of the X9511 are equivalent to the fixed terminals of a mechanical potentiometer. The minimum voltage is $-5V$ and the maximum is $+5V$. It should be noted that the terminology of V_L/R_L and V_H/R_H reference the relative position of the terminal in relation to wiper movement direction selected by the \overline{PU} and \overline{PD} inputs, and not the voltage potential on the terminal.

\overline{PU}

The debounced \overline{PU} input is for incrementing the wiper position. An on-chip pull-up holds the \overline{PU} input HIGH. A switch closure to ground or a LOW logic level will, after a debounce time, move the wiper to the next adjacent higher tap position.

\overline{PD}

The debounced \overline{PD} input is for decrementing the wiper position. An on-chip pull-up holds the \overline{PD} input HIGH. A switch closure to ground or a LOW logic level will, after a debounce time, move the wiper to the next adjacent lower tap position.

\overline{ASE}

The debounced \overline{ASE} (AUTOSTORE enable) pin can be in one of two states:

V_{IL} —AUTOSTORE is enabled. When V_{CC} powers down, an automatic store cycle takes place.

V_{IH} —AUTOSTORE is disabled. A LOW to HIGH will initiate a manual store operation. This is for the user who wishes to connect a push button switch to this pin. For every valid push, the X9511 will store the current wiper position to the EEPROM.

PIN CONFIGURATION

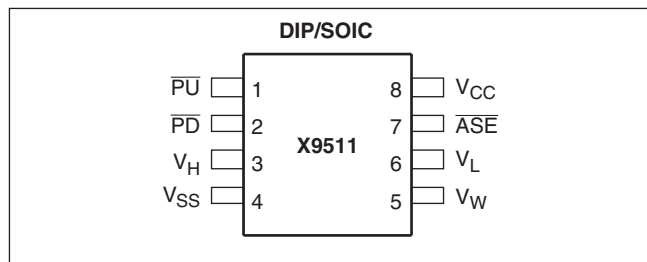

PIN NAMES

Symbol	Description
V_H/R_H	High Terminal
V_W/R_W	Wiper Terminal
V_L/R_L	Low Terminal
V_{SS}	Ground
V_{CC}	Supply Voltage
\overline{PU}	Push Up Input
\overline{PD}	Push Down Input
\overline{ASE}	AUTOSTORE Enable Input

DEVICE OPERATION

There are three sections of the X9511: the input control, counter and decode section; the EEPROM memory; and the resistor array. The input control section operates just like an up/down counter. The output of this counter is decoded to turn on a single electronic switch, connecting a point on the resistor array to the wiper output. Under the proper conditions the contents of the counter can be stored in EEPROM memory and retained for future use. The resistor array is comprised of 31 individual resistors connected in series. At either end of the array and between each resistor is an electronic switch that transfers the potential at that point to the wiper.

The X9511 is designed to interface directly to two push button switches for effectively moving the wiper up or down. The \overline{PU} and \overline{PD} inputs increment or decrement a 5-bit counter respectively. The output of this counter is decoded to select one of the thirty-two wiper positions along the resistive array. The wiper increment input, \overline{PU} and the wiper decrement input, \overline{PD} are both connected to an internal pull-up so that they normally remain HIGH. When pulled LOW by an external push button switch or a logic LOW level input, the wiper will be switched to the next adjacent tap position.

Internal debounce circuitry prevents inadvertent switching of the wiper position if \overline{PU} or \overline{PD} remain LOW for less than 40ms, typical. Each of the buttons can be pushed either once for a single increment/decrement or continuously for a multiple increments/decrements. The number of increments/decrements of the wiper position depend on how long the button is being pushed. When making a continuous push, after the first second, the increment/decrement speed increases. For the first second the device will be in the slow scan mode. Then if the button is held for longer than 1 second the device will go into the fast scan mode. As soon as the button is released the X9511 will return to a standby condition.

X9511

The wiper, when at either fixed terminal, acts like its mechanical equivalent and does not move beyond the last position. That is, the counter does not wrap around when clocked to either extreme.

AUTOSTORE

The value of the counter is stored in EEPROM memory whenever the chip senses a power-down of V_{CC} while \overline{ASE} is enabled (held LOW). When power is restored, the content of the memory is recalled and the counter reset to the last value stored.

If AUTOSTORE is to be implemented, \overline{ASE} is typically hard wired to V_{SS} . If \overline{ASE} is held HIGH during power-up and then taken LOW, the wiper will not respond to the \overline{PU} or \overline{PD} inputs until \overline{ASE} is brought HIGH and held HIGH.

Figure 1. Typical circuit with \overline{ASE} store pin controlled by push button switch

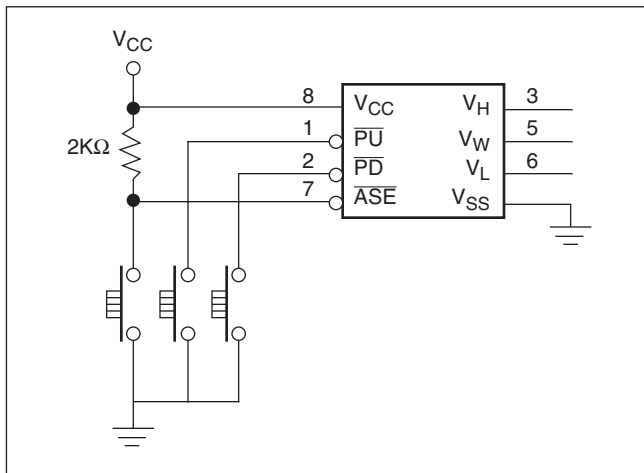

Manual (Push Button) Store

When \overline{ASE} is not enabled (held HIGH) a push button switch may be used to pull \overline{ASE} LOW and released to perform a manual store of the wiper position.

R_{TOTAL} with V_{CC} Removed

The end to end resistance of the array will fluctuate once V_{CC} is removed.

Figure 2. Typical circuit with \overline{ASE} store pin used in AUTOSTORE mode

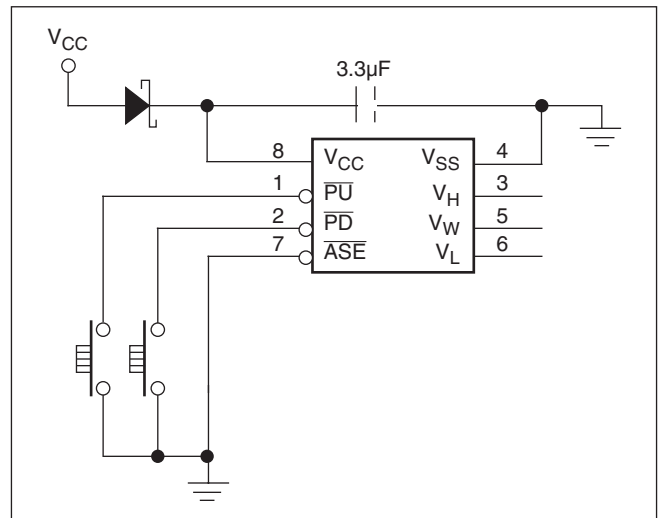

X9511

ABSOLUTE MAXIMUM RATINGS

Temperature under bias-65°C to +135°C
 Storage temperature-65°C to +150°C
 Voltage on \overline{PU} , \overline{PD} , and V_{CC}
 with respect to V_{SS}-1V to +7V
 Voltage on V_H and V_L
 referenced to V_{SS}-8V to +8V
 $\Delta V = |V_H - V_L|$
 X9511W 10V
 Lead temperature (soldering 10 seconds).....300°C
 Wiper current±1mA

ANALOG CHARACTERISTICS

Electrical Characteristics

End-to-end resistance tolerance±20%
 Power rating at 25°C
 X9511W 10mW
 Wiper current±1mA Max.
 Typical wiper resistance40Ω at 1mA
 Typical noise < -120dB/√Hz Ref: 1V

Resolution

Resistance 3%

Linearity

Absolute linearity⁽¹⁾±1.0 MI⁽²⁾
 Relative linearity⁽³⁾±0.2 MI⁽²⁾

Notes: (1) Absolute linearity is utilized to determine actual wiper voltage versus expected voltage = $(V_{W(n)}(\text{actual}) - V_{W(n)}(\text{expected})) = \pm 1 \text{ MI}$ Maximum.
 (2) 1 MI = Minimum Increment = $R_{TOT}/31$.
 (3) Relative linearity is a measure of the error in step size between taps = $V_{W(n+1)} - [V_{W(n)} + \text{MI}] = +0.2 \text{ MI}$

SYMBOL TABLE

WAVEFORM	INPUTS	OUTPUTS
	Must be steady	Will be steady
	May change from Low to High	Will change from Low to High
	May change from High to Low	Will change from High to Low
	Don't Care: Changes Allowed	Changing: State Not Known
	N/A	Center Line is High Impedance

COMMENT

Stresses above those listed under “Absolute Maximum Ratings” may cause permanent damage to the device. This is a stress rating only; functional operation of the device (at these or any other conditions above those listed in the operational sections of this specification) is not implied. Exposure to absolute maximum rating conditions for extended periods may affect device reliability.

Temperature Coefficient

-40°C to +85°C
 X9511W +300 ppm/°C Typical
 Ratiometric temperature coefficient±20 ppm

Wiper Adjustability

Unlimited wiper adjustment..... (Non-Store operation)
 Wiper position store operations..... 100,000 data changes

Physical Characteristics

Marking Includes
 Manufacturer's Trademark
 Resistance Value or Code
 Date Code

X9511

RECOMMENDED OPERATING CONDITIONS

Temperature	Min.	Max.
Commercial	0°C	+70°C
Industrial	-40°C	+85°C

Supply Voltage	Limits
X9511	5V ±10%

D.C. OPERATING CHARACTERISTICS (Over recommended operating conditions unless otherwise specified.)

Symbol	Parameter	Limits			Unit	Test Conditions
		Min.	Typ. ⁽⁴⁾	Max.		
I_{CC}	V_{CC} active current		1	3	mA	\overline{PU} or \overline{PD} held at V_{IL} the other at V_{IH}
I_{SB}	Standby supply current		100	200	μA	$\overline{PU} = \overline{PD} = V_{IH}$
I_{LI}	\overline{PU} , \overline{PD} , \overline{ASE} input leakage current			10	μA	$V_{IN} = V_{SS}$ to V_{CC}
V_{IH}	\overline{PU} , \overline{PD} , \overline{ASE} input HIGH voltage	2		$V_{CC} + 1$	V	
V_{IL}	\overline{PU} , \overline{PD} , \overline{ASE} input LOW voltage	-1		0.8	V	
R_W	Wiper resistance		40	100	Ω	Max. Wiper Current ±1mA
V_{VH}	VH terminal voltage	-5		+5	V	
V_{VL}	VL terminal voltage	-5		+5	V	
$C_{IN}^{(5)}$	\overline{ASE} , \overline{PU} , \overline{PD} input capacitance			10	pF	$V_{CC} = 5V$, $V_{IN} = 0V$, $T_A = 25^\circ C$, $f = 1MHz$

Notes: (4) Typical values are for $T_A = 25^\circ C$ and nominal supply voltage.

(5) This parameter is periodically sampled and not 100% tested.

A.C. OPERATING CHARACTERISTICS (Over recommended operating conditions unless otherwise specified.)

Symbol	Parameter	Limits			Unit
		Min.	Typ. ⁽⁶⁾	Max.	
t_{GAP}	Time between two separate push button events	0			μs
t_{DB}	Debounce time		30	60	ms
$t_{S SLOW}$	After debounce to wiper change on a slow mode	100	250	375	ms
$t_{S FAST}^{(7)}$	Wiper change on a fast mode	25	50	75	ms
$t_{PU}^{(7)}$	Power up to wiper stable			500	μs
$t_R V_{CC}^{(7)}$	V_{CC} power-up rate	0.2		50	mV/μs
$t_{ASTO}^{(7)}$	AUTOSTORE cycle time	2			ms
$V_{ASTH}^{(7)}$	AUTOSTORE threshold voltage		4		V
$V_{ASEND}^{(7)}$	AUTOSTORE cycle end voltage		3.5		V

POWER UP AND DOWN REQUIREMENTS

There are no restrictions on the sequencing of V_{CC} and the voltage applied to the potentiometer pins during power-up or power-down conditions. During power-up, the data sheet parameters for the DCP do not fully apply until 1ms after V_{CC} reaches its final value. The V_{CC} ramp rate spec is always in effect.

AUTOSTORE Cycle Timing Diagram

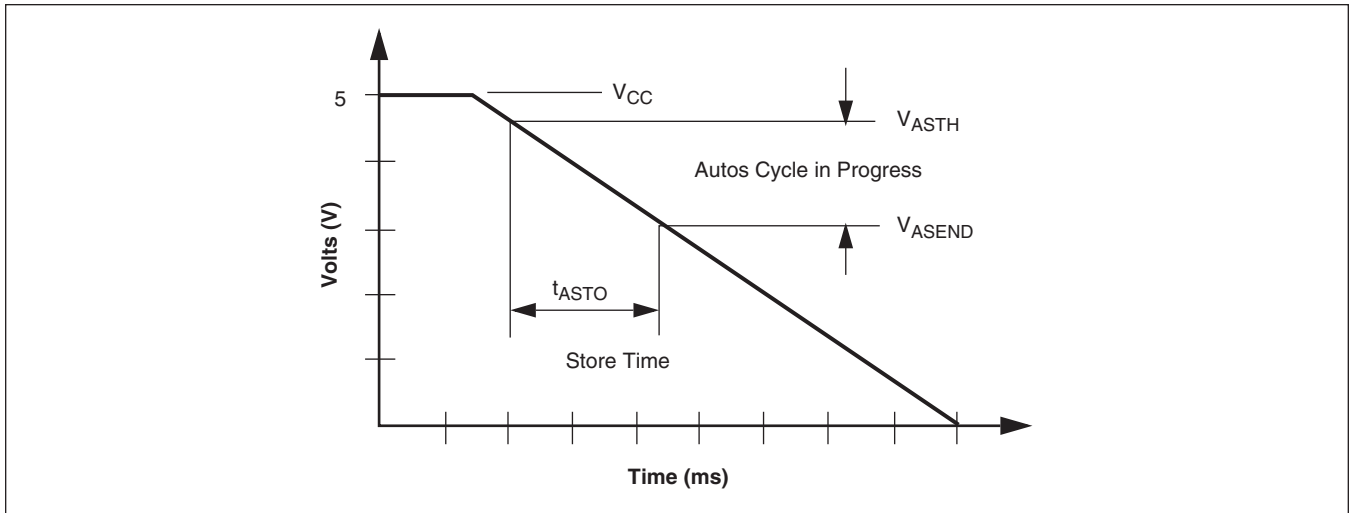

- Notes:** V_{ASTH} —AUTOSTORE threshold voltage
 V_{ASEND} —AUTOSTORE cycle end voltage
 t_{ASTO} —AUTOSTORE cycle time
 (6) Typical values are for $T_A = 25^\circ\text{C}$ and nominal supply voltage.
 (7) This parameter is periodically sampled and not 100% tested.

Slow Mode Timing

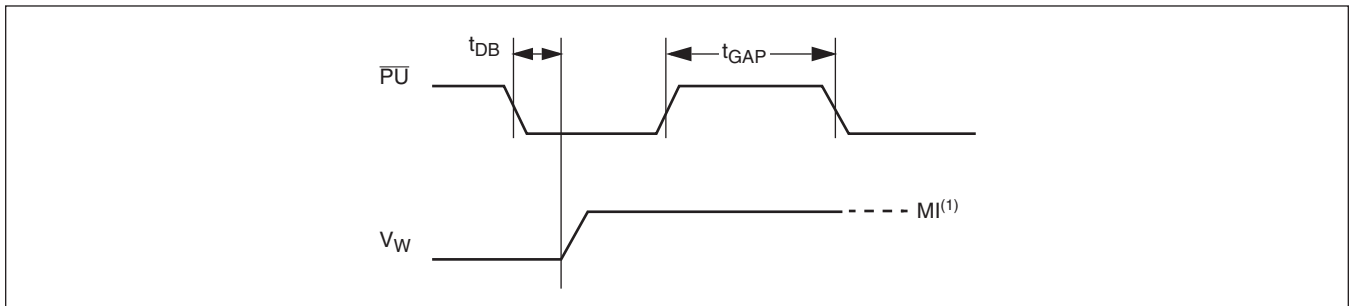

Note: (1) MI in the A.C. timing diagram refers to the minimum incremental change in the wiper voltage.

X9511

Fast Mode Timing

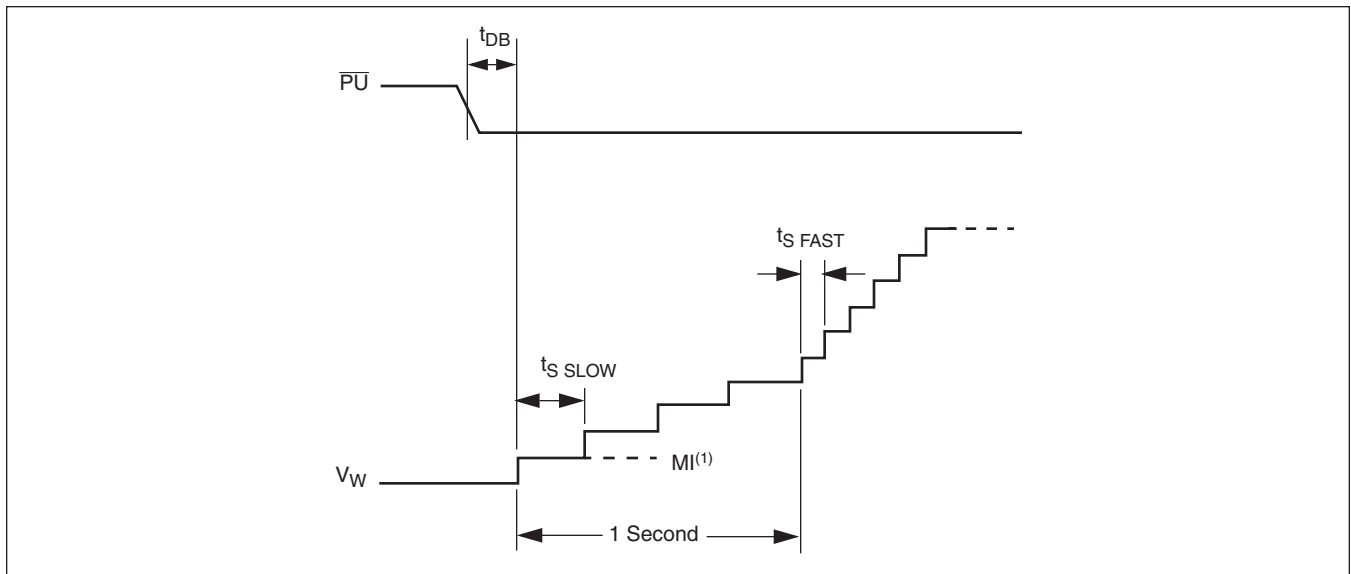

Note: (1) MI in the A.C. timing diagram refers to the minimum incremental change in the wiper voltage.

PACKAGING INFORMATION

8-Lead Plastic Dual In-Line Package Type P

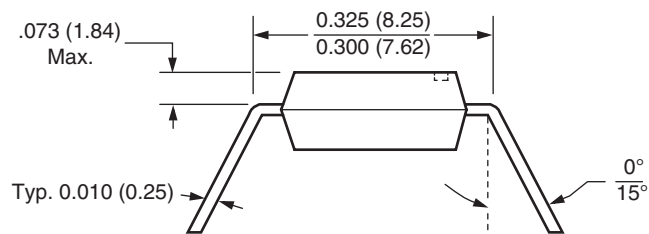
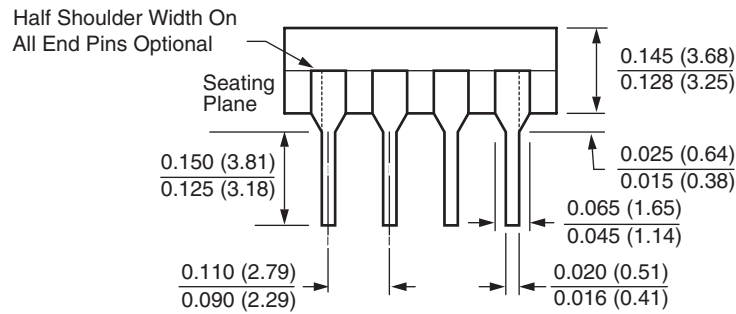
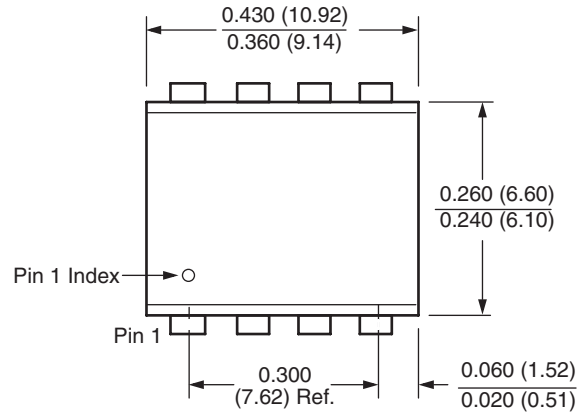

NOTE:

1. ALL DIMENSIONS IN INCHES (IN PARENTHESES IN MILLIMETERS)
2. PACKAGE DIMENSIONS EXCLUDE MOLDING FLASH

PACKAGING INFORMATION

8-Lead Plastic Small Outline Gull Wing Package Type S

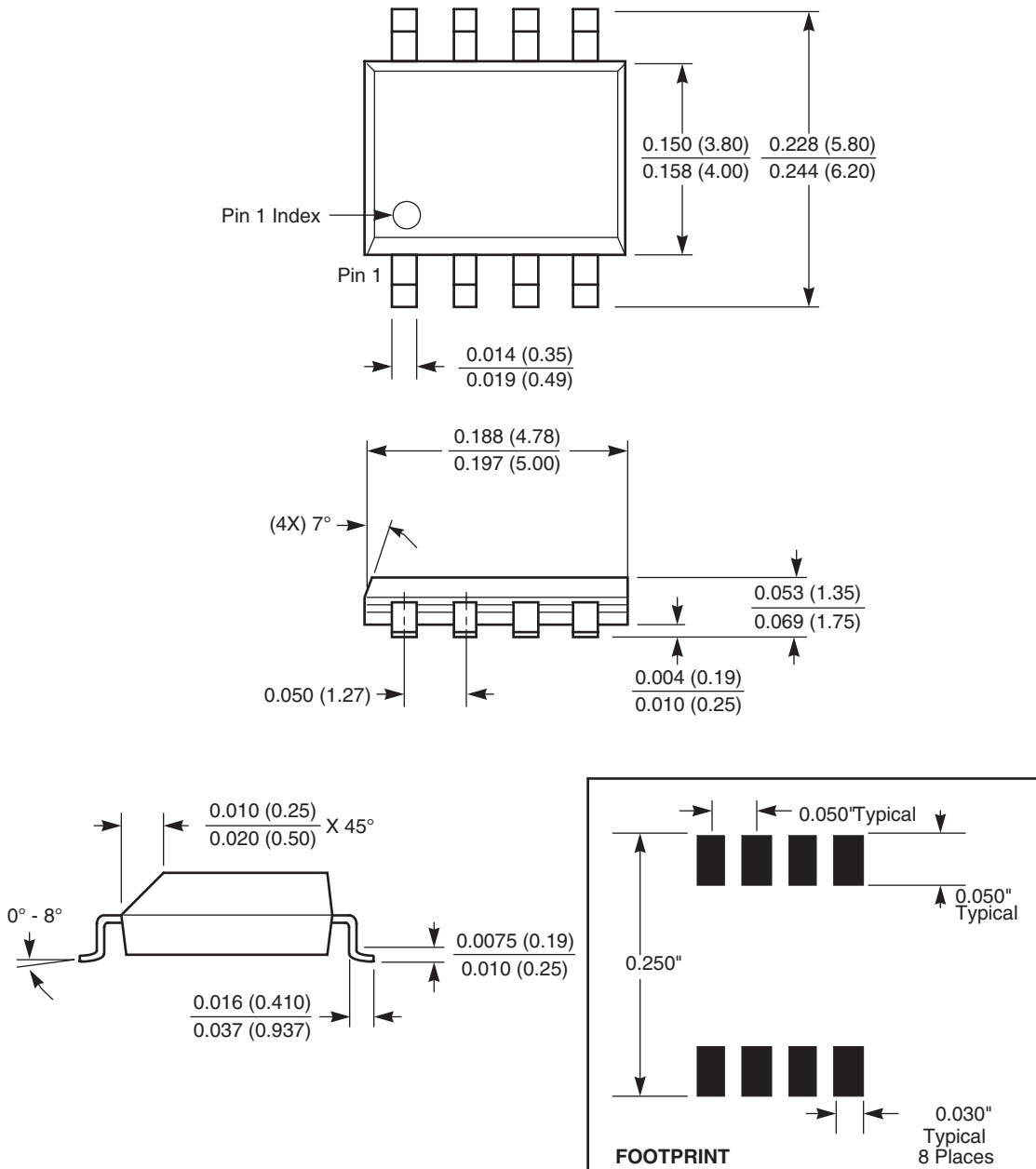

NOTE: ALL DIMENSIONS IN INCHES (IN PARENTHESES IN MILLIMETERS)

X9511

ORDERING INFORMATION

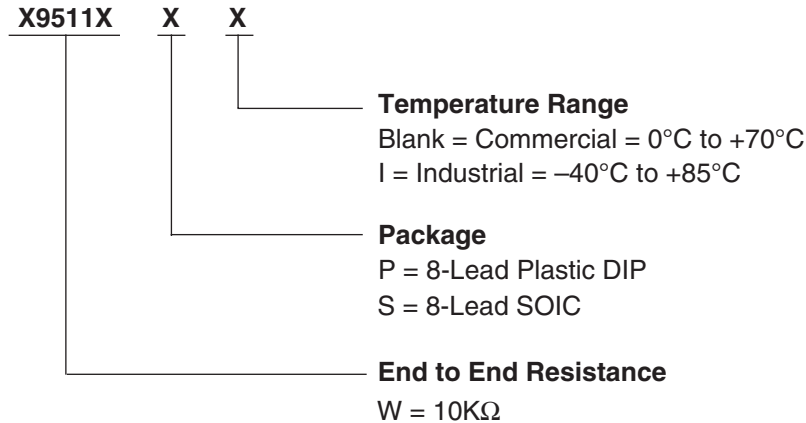

LIMITED WARRANTY

©Xicor, Inc. 2000 Patents Pending

Devices sold by Xicor, Inc. are covered by the warranty and patent indemnification provisions appearing in its Terms of Sale only. Xicor, Inc. makes no warranty, express, statutory, implied, or by description regarding the information set forth herein or regarding the freedom of the described devices from patent infringement. Xicor, Inc. makes no warranty of merchantability or fitness for any purpose. Xicor, Inc. reserves the right to discontinue production and change specifications and prices at any time and without notice.

Xicor, Inc. assumes no responsibility for the use of any circuitry other than circuitry embodied in a Xicor, Inc. product. No other circuits, patents, or licenses are implied.

TRADEMARK DISCLAIMER:

Xicor and the Xicor logo are registered trademarks of Xicor, Inc. AutoStore, Direct Write, Block Lock, SerialFlash, MPS, and XDCP are also trademarks of Xicor, Inc. All others belong to their respective owners.

U.S. PATENTS

Xicor products are covered by one or more of the following U.S. Patents: 4,326,134; 4,393,481; 4,404,475; 4,450,402; 4,486,769; 4,488,060; 4,520,461; 4,533,846; 4,599,706; 4,617,652; 4,668,932; 4,752,912; 4,829,482; 4,874,967; 4,883,976; 4,980,859; 5,012,132; 5,003,197; 5,023,694; 5,084,667; 5,153,880; 5,153,691; 5,161,137; 5,219,774; 5,270,927; 5,324,676; 5,434,396; 5,544,103; 5,587,573; 5,835,409; 5,977,585. Foreign patents and additional patents pending.

LIFE RELATED POLICY

In situations where semiconductor component failure may endanger life, system designers using this product should design the system with appropriate error detection and correction, redundancy and back-up features to prevent such an occurrence.

Xicor's products are not authorized for use in critical components in life support devices or systems.

1. Life support devices or systems are devices or systems which, (a) are intended for surgical implant into the body, or (b) support or sustain life, and whose failure to perform, when properly used in accordance with instructions for use provided in the labeling, can be reasonably expected to result in a significant injury to the user.
2. A critical component is any component of a life support device or system whose failure to perform can be reasonably expected to cause the failure of the life support device or system, or to affect its safety or effectiveness.