

### Single IGBT A-Series Module 600 Amperes/1200 Volts

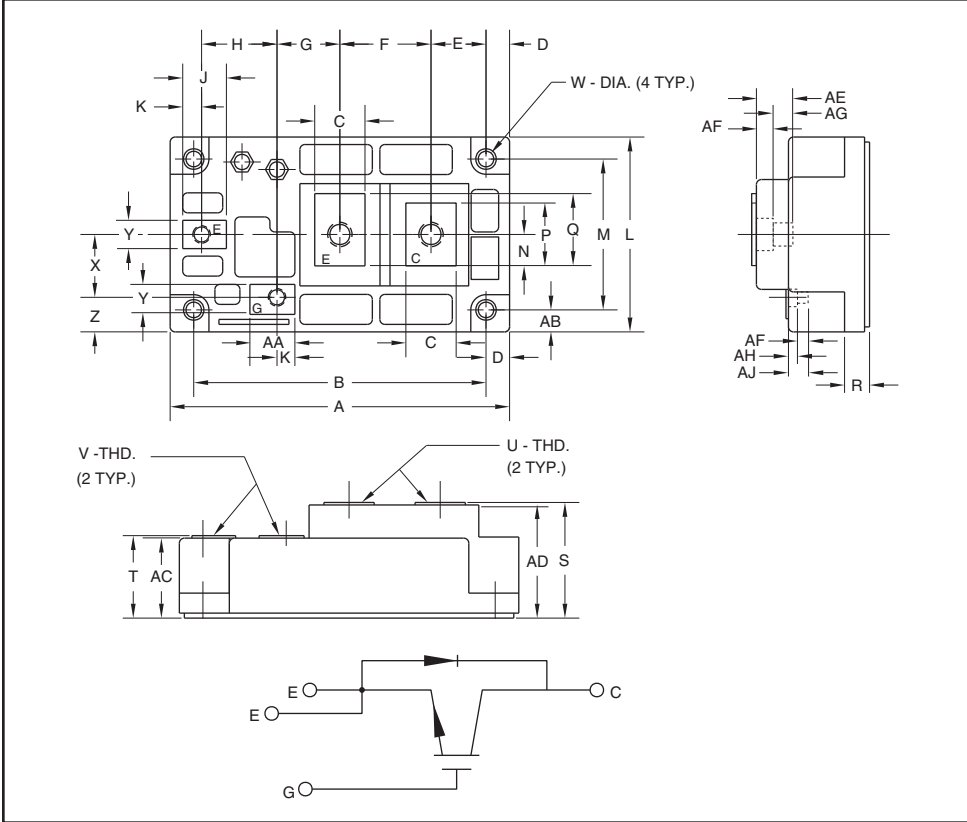

#### Description:

Powerex IGBT Modules are designed for use in switching applications. Each module consists of one IGBT Transistor in a single configuration with a reverse connected super-fast recovery free-wheel diode. All components and interconnects are isolated from the heat sinking baseplate, offering simplified system assembly and thermal management.

#### Features:

- Low Drive Power
- Low  $V_{CE(sat)}$
- Discrete Super-Fast Recovery Free-Wheel Diode
- Isolated Baseplate for Easy Heat Sinking

#### Applications:

- DC Chopper
- Inverter
- UPS
- Forklift

#### Ordering Information:

Example: Select the complete part module number you desire from the table below -i.e. CM600HA-24A is a 1200V ( $V_{CES}$ ), 600 Ampere Single IGBT Power Module.

#### Outline Drawing and Circuit Diagram

Dimensions	Inches	Millimeters
A	4.25	108.0
B	3.66±0.01	93.0±0.25
C	0.63	16.0
D	0.30	7.5
E	0.69	17.5
F	1.14	29.0
G	0.79	20.0
H	0.94	24.0
J	0.55	13.9
K	0.24	6.0
L	2.44	62.0
M	1.89±0.01	48.0±0.25
N	0.39	10.0
P	0.39	20.0
Q	0.51	23.0
R	0.33	8.5
S	1.42+0.04/-0.02	36.0+1/-0.5

Dimensions	Inches	Millimeters
T	1.02+0.04/-0.02	25.8+1/-0.5
U	M6 Metric	M6
V	M4 Metric	M4
W	0.256 Dia.	6.5 Dia.
X	0.79	20.0
Y	0.35	9.0
Z	0.43	11.0
AA	0.53	13.55
AB	0.27	7.0
AC	0.98	25.0
AD	1.38	35.0
AE	0.45	11.5
AF	0.25.0	
AG	0.25	6.5
AH	0.12	3.2
AJ	0.32	8.2

Type	Current Rating Amperes	$V_{CES}$ Volts (x 50)
CM	600	24

**CM600HA-24A**  
**Single IGBT A-Series Module**  
 600 Amperes/1200 Volts

**Maximum Ratings,  $T_j = 25^\circ\text{C}$  unless otherwise specified**

Characteristics	Symbol	Rating	Units
Collector-Emitter Voltage ( $V_{GE} = 0V$ )	$V_{CES}$	1200	Volts
Gate-Emitter Voltage ( $V_{CE} = 0V$ )	$V_{GES}$	$\pm 20$	Volts
Collector Current (DC, $T_C = 80^\circ\text{C}$ )*2,*4	$I_C$	600	Amperes
Collector Current (Pulse, Repetitive)*3	$I_{CRM}$	1200	Amperes
Total Power Dissipation ( $T_C = 25^\circ\text{C}$ )*2,*4	$P_{tot}$	3670	Watts
Emitter Current*2	$I_E^{*1}$	600	Amperes
Emitter Current (Pulse, Repetitive)*3	$I_{ERM}^{*1}$	1200	Amperes
Isolation Voltage (Charged Part to Baseplate, RMS, $f = 60\text{Hz}$ , AC 1 minute)	$V_{ISO}$	2500	Volts
Junction Temperature	$T_j$	-40 ~ +150	$^\circ\text{C}$
Storage Temperature	$T_{stg}$	-40 ~ +125	$^\circ\text{C}$

\*1 Represent ratings and characteristics of the anti-parallel, emitter-to-collector free wheeling diode (FWDi).

\*2 The device junction temperature is  $T_{j(max)}$  rating (150 $^\circ\text{C}$ ) or less.

\*3 Pulse width and repetition rate should be such that device junction temperature ( $T_j$ ) does not exceed  $T_{j(max)}$  rating.

\*4 Case temperature ( $T_C$ ) is measured on the surface of the baseplate just under the chip. Refer to the figure to the right for chip location.

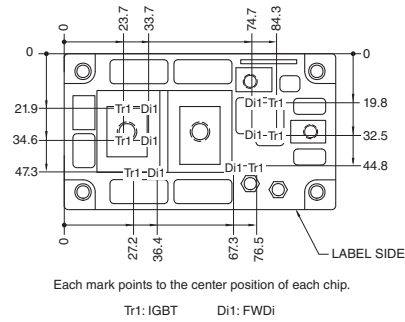

**CM600HA-24A**  
**Single IGBT A-Series Module**  
 600 Amperes/1200 Volts

**Electrical Characteristics,  $T_j = 25^\circ\text{C}$  unless otherwise specified**

Characteristics	Symbol	Test Conditions	Min.	Typ.	Max.	Units
Collector-Emitter Cutoff Current	$I_{CES}$	$V_{CE} = V_{CES}, V_{GE} = 0V$	—	—	1.0	mA
Gate-Emitter Leakage Current	$I_{GES}$	$V_{GE} = V_{GES}, V_{CE} = 0V$	—	—	1.5	$\mu\text{A}$
Gate-Emitter Threshold Voltage	$V_{GE(th)}$	$I_C = 60\text{mA}, V_{CE} = 10V$	6	7	8	Volts
Collector-Emitter Saturation Voltage	$V_{CE(sat)}$	$I_C = 600\text{A}, V_{GE} = 15V, T_j = 25^\circ\text{C}^{*5}$	—	2.1	3.0	Volts
		$I_C = 600\text{A}, V_{GE} = 15V, T_j = 125^\circ\text{C}^{*5}$	—	2.4	—	Volts
Forward Transfer Admittance	$ y_{fs} $	$I_C = 600\text{A}, V_{CE} = 10V^{*5}$	180	—	—	S
Input Capacitance	$C_{ies}$		—	—	105	nF
Output Capacitance	$C_{oes}$	$V_{CE} = 10V, V_{GE} = 0V$	—	—	9.0	nF
Reverse Transfer Capacitance	$C_{res}$		—	—	2.0	nF
Gate Charge	$Q_G$	$V_{CC} = 600V, I_C = 600\text{A}, V_{GE} = 15V$	—	3000	—	nC
Turn-on Delay Time	$t_{d(on)}$		—	—	660	ns
Rise Time	$t_r$	$V_{CC} = 600V, I_C = 600\text{A}, V_{GE} = \pm 15V,$	—	—	190	ns
Turn-off Delay Time	$t_{d(off)}$	$R_G = 0.52\Omega, \text{Inductive Load}$	—	—	700	ns
Fall Time	$t_f$		—	—	350	ns
Emitter-Collector Voltage	$V_{EC}^{*1}$	$I_E = 600\text{A}, V_{GE} = 0V^{*5}$	—	3.0	3.8	Volts
Reverse Recovery Time	$t_{rr}^{*1}$	$V_{CC} = 600V, I_E = 600\text{A}, V_{GE} = \pm 15V$	—	—	250	ns
Reverse Recovery Charge	$Q_{rr}^{*1}$	$R_G = 0.52\Omega, \text{Inductive Load}$	—	19	—	$\mu\text{C}$
Internal Gate Resistance	$r_g$	$T_C = 25^\circ\text{C}$	—	1.0	—	$\Omega$
External Gate Resistance	$R_G$		0.52	—	7.8	$\Omega$

\*1 Represent ratings and characteristics of the anti-parallel, emitter-to-collector free wheeling diode (FWDI).

\*5 Pulse width and repetition rate should be such as to cause negligible temperature rise.

**CM600HA-24A**  
**Single IGBT A-Series Module**  
 600 Amperes/1200 Volts

### Thermal Resistance Characteristics

Characteristics	Symbol	Test Conditions	Min.	Typ.	Max.	Units
Thermal Resistance, Junction to Case	$R_{th(j-c)Q}$	IGBT Part <sup>*4</sup>	—	—	34	K/kW
Thermal Resistance, Junction to Case	$R_{th(j-c)D}$	FWDi Part <sup>*4</sup>	—	—	53	K/kW
Contact Thermal Resistance, Case to Heatsink	$R_{th(c-f)}$	Thermal Grease Applied, Per 1 Module <sup>*4,*7</sup>	—	15	—	K/kW

### Mechanical Characteristics

Mounting Torque	$M_t$	Main Terminal, M6 Screw	17	22	26	in-lb
Mounting Torque	$M_t$	G/E Auxiliary Terminals	8	10	13	in-lb
Mounting Torque	$M_s$	Mounting to Heatsink, M6 Screw	22	27	31	in-lb
Weight	m			480		g
Flatness of Baseplate	$e_c$	On Centerline X, Y <sup>*6</sup>	±0	—	+100	μm

<sup>\*4</sup> Case temperature ( $T_C$ ) and heatsink temperature ( $T_S$ ) is measured on the surface (mounting side) of the baseplate and the heatsink side just under the chips. Refer to the figure to the right for chip location.

The heatsink thermal resistance should be measured just under the chips.

<sup>\*6</sup> Baseplate (mounting side) flatness measurement points (X, Y) are shown in the figure below.

<sup>\*7</sup> Typical value is measured by using thermally conductive grease of  $\lambda = 0.9$  [W/(m • K)].

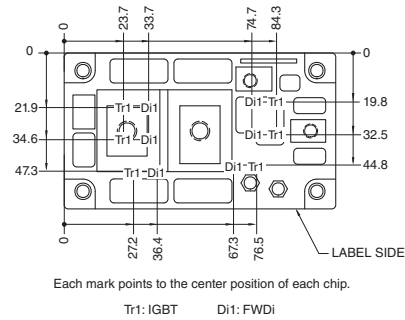
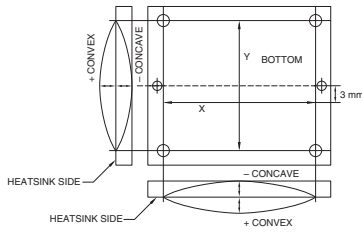

**CM600HA-24A**  
**Single IGBT A-Series Module**  
 600 Amperes/1200 Volts

**OUTPUT CHARACTERISTICS (TYPICAL)**

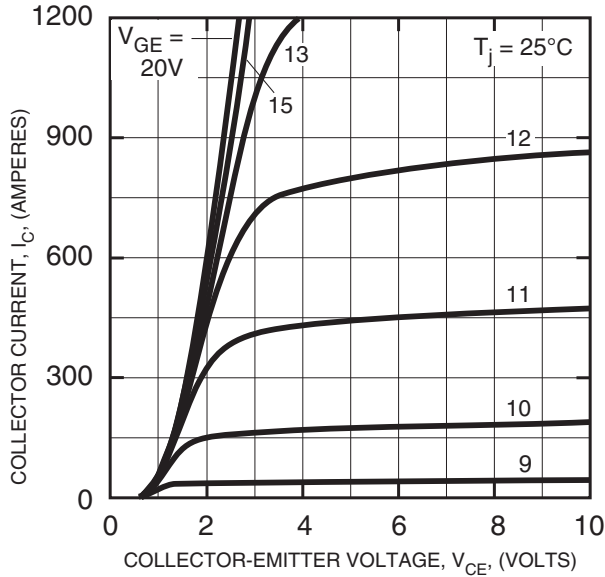

**COLLECTOR-EMITTER SATURATION VOLTAGE CHARACTERISTICS (TYPICAL)**

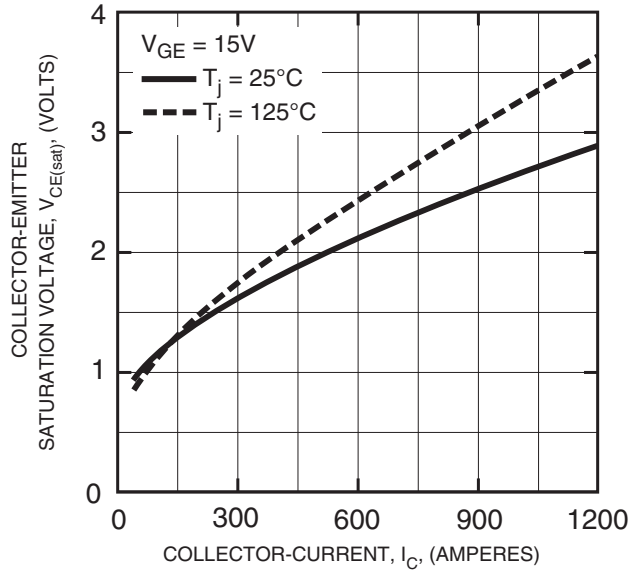

**COLLECTOR-EMITTER SATURATION VOLTAGE CHARACTERISTICS (TYPICAL)**

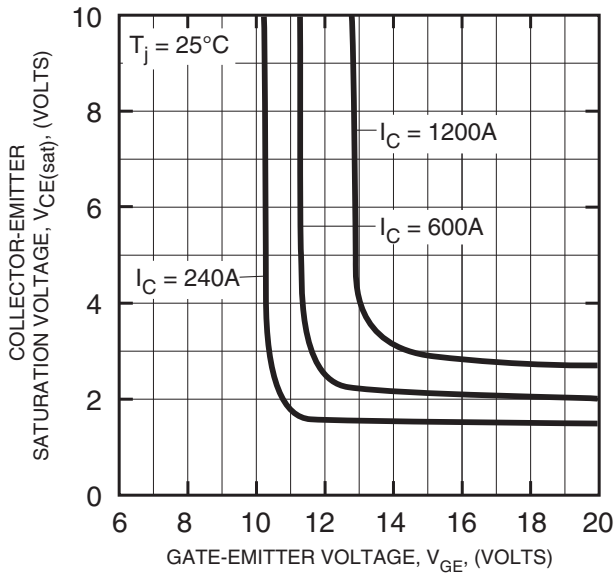

**FREE-WHEEL DIODE FORWARD CHARACTERISTICS (TYPICAL)**

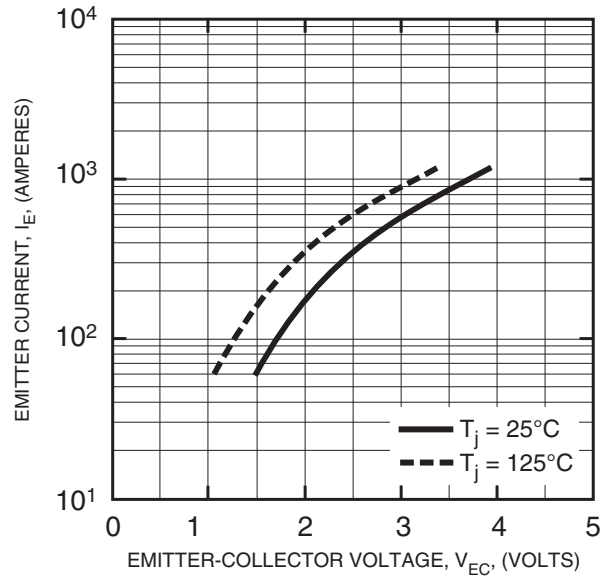

**CM600HA-24A**  
**Single IGBT A-Series Module**  
 600 Amperes/1200 Volts

**CAPACITANCE VS.  $V_{CE}$**   
(TYPICAL)

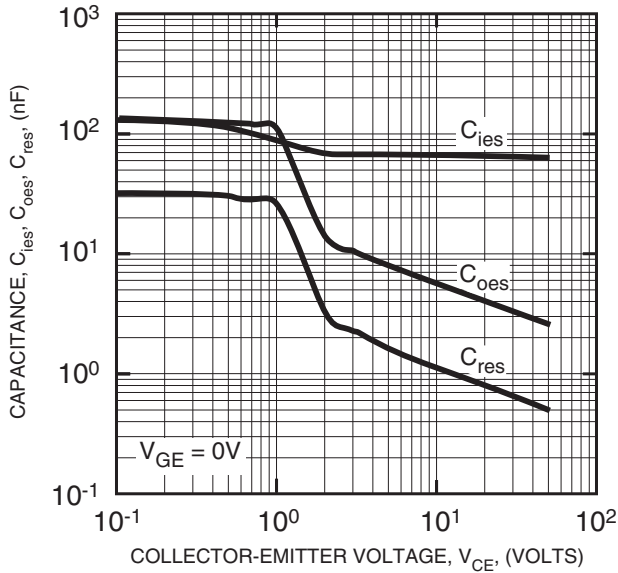

**HALF-BRIDGE SWITCHING CHARACTERISTICS**  
(TYPICAL)

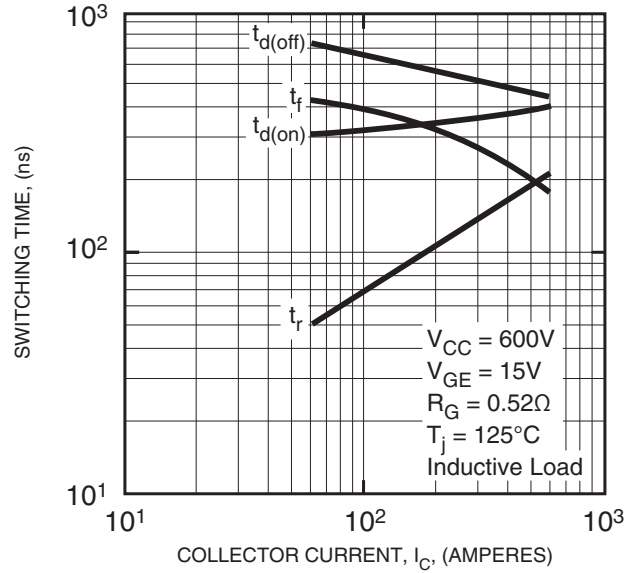

**REVERSE RECOVERY CHARACTERISTICS**  
(TYPICAL)

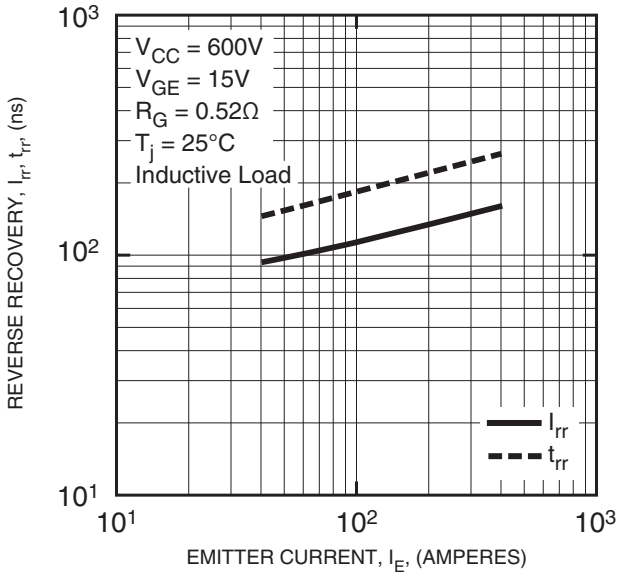

**GATE CHARGE VS.  $V_{GE}$**

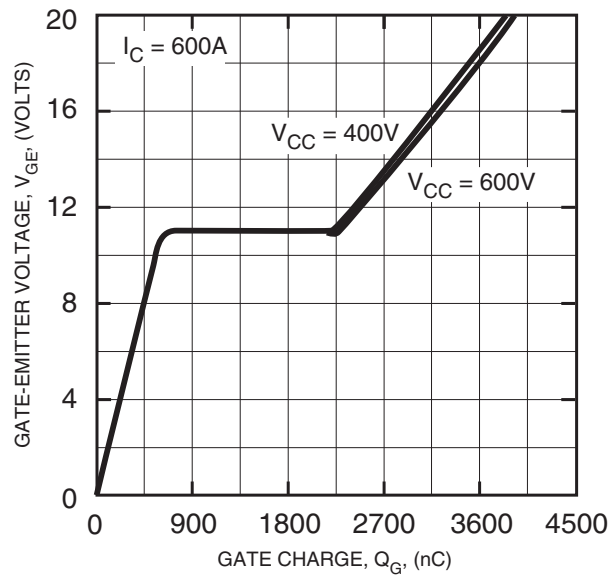

**CM600HA-24A**  
**Single IGBT A-Series Module**  
 600 Amperes/1200 Volts

**SWITCHING LOSS VS. COLLECTOR CURRENT (TYPICAL)**

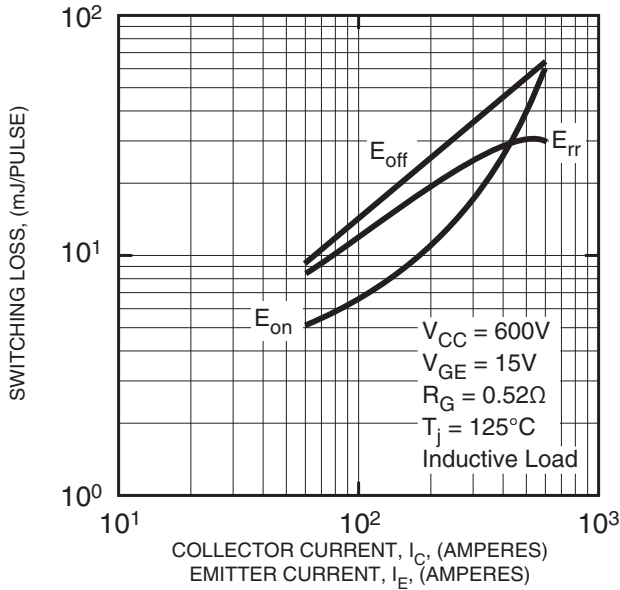

**SWITCHING LOSS VS. GATE RESISTANCE (TYPICAL)**

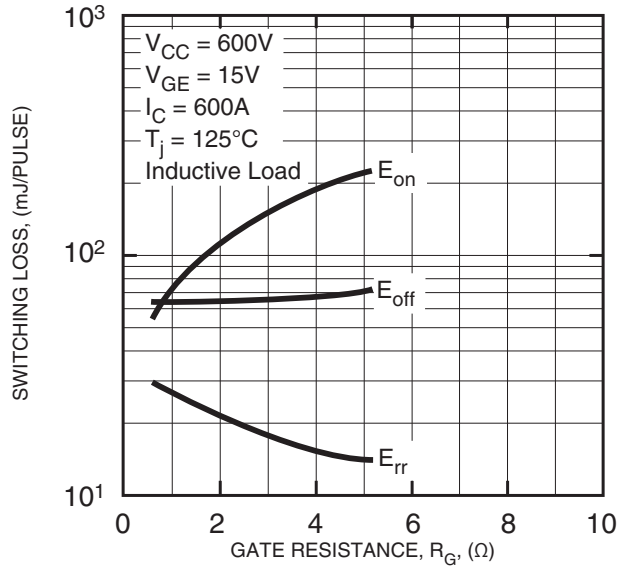

**TRANSIENT THERMAL IMPEDANCE CHARACTERISTICS (IGBT & FWDi)**

