

## ACEPACK™ 1 converter inverter brake, 1200 V, 15 A trench gate field-stop IGBT M series, soft diode and NTC

Datasheet - production data

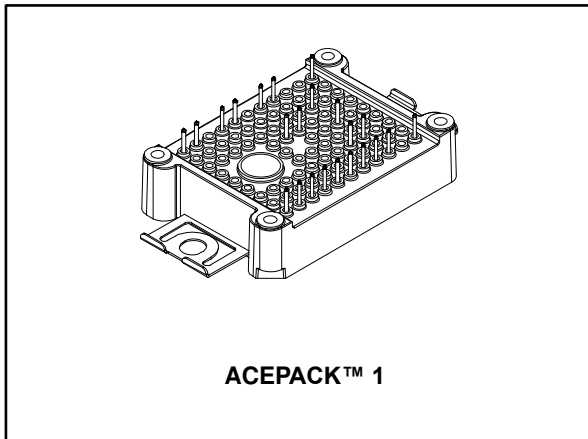
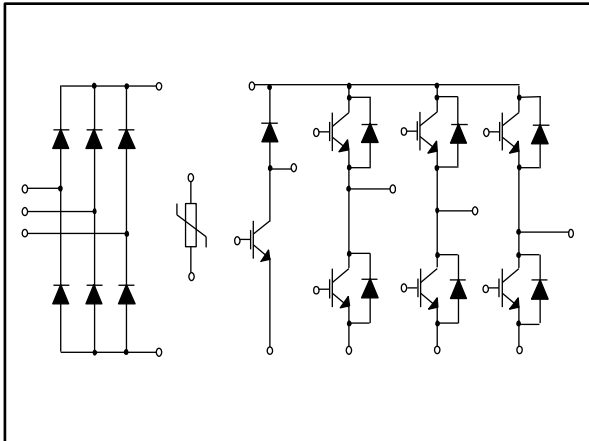

Figure 1: Internal electrical schematic



### Features

- ACEPACK™ 1 power module
  - DBC Cu Al<sub>2</sub>O<sub>3</sub> Cu
- Converter inverter brake topology
  - 1600 V, very low drop rectifiers for converter
  - 1200 V, 15 A IGBTs and diodes
  - $V_{CE(sat)}$ : 1.95 V @  $I_C = 15$  A
  - Soft and fast recovery diode
- Integrated NTC

### Applications

- Inverters
- Motor drives

### Description

This power module is a converter-inverter brake (CIB) topology in an ACEPACK™ 1 package with NTC, integrating the advanced trench gate field-stop technology from STMicroelectronics. This new IGBT technology represents the best compromise between conduction and switching loss, to maximize the efficiency of any converter system up to 20 kHz.

Table 1: Device summary

Order code	Marking	Package	Leads type
A1C15S12M3	A1C15S12M3	ACEPACK™ 1	Solder contact pins

---

# Contents

<b>1</b>	<b>Electrical ratings .....</b>	<b>3</b>
1.1	Inverter stage .....	3
1.1.1	IGBTs.....	3
1.1.2	Diode .....	4
1.2	Brake stage .....	5
1.2.1	IGBT .....	5
1.2.2	Diode .....	7
1.3	Converter stage.....	7
1.4	NTC.....	8
1.5	Package .....	9
<b>2</b>	<b>Electrical characteristics curves .....</b>	<b>10</b>
<b>3</b>	<b>Test circuits .....</b>	<b>13</b>
<b>4</b>	<b>Topology and pin description .....</b>	<b>14</b>
<b>5</b>	<b>Package information .....</b>	<b>15</b>
5.1	ACEPACK™ 1 CIB solder pins package information .....	16
<b>6</b>	<b>Revision history .....</b>	<b>17</b>

# 1 Electrical ratings

## 1.1 Inverter stage

Limiting values at  $T_j = 25\text{ °C}$ , unless otherwise specified.

### 1.1.1 IGBTs

**Table 2: Absolute maximum ratings of the IGBTs, inverter stage**

Symbol	Description	Value	Unit
$V_{CES}$	Collector-emitter voltage ( $V_{GE} = 0$ )	1200	V
$I_C$	Continuous collector current at $T_c = 100\text{ °C}$	15	A
$I_{CP}^{(1)}$	Pulsed collector current ( $t_P = 1\text{ ms}$ )	30	A
$V_{GE}$	Gate-emitter voltage	$\pm 20$	V
$P_{TOT}$	Total power dissipation IGBT ( $T_{JMAX} = 175\text{ °C}$ )	142.8	W
$T_{JMAX}$	Maximum junction temperature	175	°C
$T_{Jop}$	Operative temperature range under switching conditions	-40 to 150	°C

**Notes:**

<sup>(1)</sup>Pulse width limited by maximum junction temperature.

**Table 3: Electrical characteristics of the IGBTs, inverter stage**

Symbol	Parameter	Test conditions	Min.	Typ.	Max.	Unit
$V_{(BR)CES}$	Collector-emitter breakdown voltage	$I_C = 1\text{ mA}$ , $V_{GE} = 0\text{ V}$	1200			V
$V_{CE(sat)}$	Collector-emitter saturation voltage	$V_{GE} = 15\text{ V}$ , $I_C = 15\text{ A}$		1.95	2.45	V
		$V_{GE} = 15\text{ V}$ , $I_C = 15\text{ A}$ , $T_J = 150\text{ °C}$		2.3		V
$V_{GE(th)}$	Gate threshold voltage	$V_{CE} = V_{GE}$ , $I_C = 1\text{ mA}$	5	6	7	V
$I_{CES}$	Collector cut-off current	$V_{GE} = 0\text{ V}$ , $V_{CE} = 1200\text{ V}$			100	$\mu\text{A}$
$I_{GES}$	Gate-emitter leakage current	$V_{CE} = 0\text{ V}$ , $V_{GE} = \pm 20\text{ V}$			$\pm 500$	nA
$C_{ies}$	Input capacitance	$V_{CE} = 25\text{ V}$ , $f = 1\text{ MHz}$ , $V_{GE} = 0\text{ V}$		985		pF
$C_{oes}$	Output capacitance			118		pF
$C_{res}$	Reverse transfer capacitance			40		pF
$Q_g$	Total gate charge	$V_{CC} = 960\text{ V}$ , $I_C = 15\text{ A}$ , $V_{GE} = \pm 15\text{ V}$		71		nC
$t_{d(on)}$	Turn-on delay time	$V_{CC} = 600\text{ V}$ , $I_C = 15\text{ A}$ , $R_G = 22\ \Omega$ , $V_{GE} = \pm 15\text{ V}$ , $di/dt = 820\text{ A}/\mu\text{s}$		120		ns
$t_r$	Current rise time			14.5		ns
$E_{on}^{(1)}$	Turn-on switching energy				0.59	

Symbol	Parameter	Test conditions	Min.	Typ.	Max.	Unit
$t_{d(off)}$	Turn-off delay time	$V_{CC} = 600\text{ V}$ , $I_C = 15\text{ A}$ , $R_G = 22\ \Omega$ , $V_{GE} = \pm 15\text{ V}$ , $dv/dt = 8200\text{ V}/\mu\text{s}$ ;		115		ns
$t_f$	Current fall time			84		ns
$E_{off}^{(2)}$	Turn-off switching energy			0.83		mJ
$t_{d(on)}$	Turn-on delay time	$V_{CC} = 600\text{ V}$ , $I_C = 15\text{ A}$ , $R_G = 22\ \Omega$ , $V_{GE} = \pm 15\text{ V}$ , $di/dt = 690\text{ A}/\mu\text{s}$ , $T_J = 150\text{ }^\circ\text{C}$		122		ns
$t_r$	Current rise time			17		ns
$E_{on}^{(1)}$	Turn-on switching energy			1.08		mJ
$t_{d(off)}$	Turn-off delay time	$V_{CC} = 600\text{ V}$ , $I_C = 15\text{ A}$ , $R_G = 22\ \Omega$ , $V_{GE} = \pm 15\text{ V}$ , $dv/dt = 7000\text{ V}/\mu\text{s}$ , $T_J = 150\text{ }^\circ\text{C}$		122		ns
$t_f$	Current fall time			146		ns
$E_{off}^{(2)}$	Turn-off switching energy			1.06		mJ
$t_{SC}$	Short-circuit withstand time	$V_{CC} \leq 600\text{ V}$ , $V_{GE} \leq 15\text{ V}$ , $T_{Jstart} \leq 150\text{ }^\circ\text{C}$	10			$\mu\text{s}$
$R_{THj-c}$	Thermal resistance junction to case	each IGBT		0.95	1.05	$^\circ\text{C}/\text{W}$
$R_{THc-h}$	Thermal resistance case to heatsink	each IGBT, $\lambda_{grease} = 1\text{ W}/(\text{m}\cdot^\circ\text{C})$		0.90		$^\circ\text{C}/\text{W}$

**Notes:**

(1) Including the reverse recovery of the diode.

(2) Including also the tail of the collector current.

**1.1.2 Diode**Limiting values at  $T_J = 25\text{ }^\circ\text{C}$ , unless otherwise specified.**Table 4: Absolute maximum ratings of the diode, inverter stage**

Symbol	Parameter	Value	Unit
$V_{RRM}$	Repetitive peak reverse voltage	1200	V
$I_F$	Continuous forward current at ( $T_C = 100\text{ }^\circ\text{C}$ )	15	A
$I_{FF}^{(1)}$	Pulsed forward current	30	A
$T_{JMAX}$	Maximum junction temperature	175	$^\circ\text{C}$
$T_{Jop}$	Operative temperature range under switching conditions	-40 to 150	$^\circ\text{C}$

**Notes:**

(1) Pulse width limited by maximum junction temperature.

Table 5: Electrical characteristics of the diode, inverter stage

Symbol	Parameter	Test conditions	Min.	Typ.	Max.	Unit
V <sub>F</sub>	Forward voltage	I <sub>F</sub> = 15 A	-	3.0	3.8	V
		I <sub>F</sub> = 15 A, T <sub>J</sub> = 150 °C	-	2.1		
t <sub>rr</sub>	Reverse recovery time	I <sub>F</sub> = 15 A, V <sub>R</sub> = 600 V, V <sub>GE</sub> = ±15 V, di <sub>F</sub> /dt = 820 A/μs	-	190		ns
Q <sub>rr</sub>	Reverse recovery charge		-	1.45		μC
I <sub>rrm</sub>	Reverse recovery current		-	23		A
E <sub>rec</sub>	Reverse recovery energy		-	0.55		mJ
t <sub>rr</sub>	Reverse recovery time	I <sub>F</sub> = 15 A, V <sub>R</sub> = 600 V, V <sub>GE</sub> = ±15 V, di <sub>F</sub> /dt = 690 A/μs, T <sub>J</sub> = 150 °C	-	400		ns
Q <sub>rr</sub>	Reverse recovery charge		-	2.75		μC
I <sub>rrm</sub>	Reverse recovery current		-	25		A
E <sub>rec</sub>	Reverse recovery energy		-	1.2		mJ
R <sub>THj-c</sub>	Thermal resistance junction to case	Each diode	-	1.60	1.75	°C/W
R <sub>THc-h</sub>	Thermal resistance case to heatsink	Each diode, λ <sub>grease</sub> = 1 W/(m·°C)	-	1.15		°C/W

## 1.2 Brake stage

Limiting values at T<sub>j</sub> = 25 °C, unless otherwise specified.

### 1.2.1 IGBT

Table 6: Absolute maximum ratings of the IGBT, brake stage

Symbol	Parameter	Value	Unit
V <sub>CES</sub>	Collector-emitter voltage (V <sub>GE</sub> = 0)	1200	V
I <sub>c</sub>	Continuous collector current (T <sub>c</sub> = 100 °C)	15	A
I <sub>CP</sub> <sup>(1)</sup>	Pulsed collector current	30	A
V <sub>GE</sub>	Gate-emitter voltage	±20	V
P <sub>TOT</sub>	Total power dissipation	142.8	W
T <sub>JMAX</sub>	Maximum junction temperature	175	°C
T <sub>Jop</sub>	Operative temperature range under switching conditions	-40 to 150	°C

#### Notes:

<sup>(1)</sup>Pulse width limited by maximum junction temperature.

Table 7: Electrical characteristics of the IGBT, brake stage

Symbol	Parameter	Test conditions	Min.	Typ.	Max.	Unit
$V_{(BR)CES}$	Collector-emitter breakdown voltage	$I_C = 1 \text{ mA}$ , $V_{GE} = 0 \text{ V}$	1200			V
$V_{CE(sat)}$	Collector-emitter saturation voltage	$V_{GE} = 15 \text{ V}$ , $I_C = 15 \text{ A}$		1.95	2.45	V
		$V_{GE} = 15 \text{ V}$ , $I_C = 15 \text{ A}$ , $T_J = 150 \text{ }^\circ\text{C}$		2.3		
$V_{GE(th)}$	Gate threshold voltage	$V_{CE} = V_{GE}$ , $I_C = 1 \text{ mA}$	5	6	7	V
$I_{CES}$	Collector cut-off current	$V_{GE} = 0 \text{ V}$ , $V_{CE} = 1200 \text{ V}$			100	$\mu\text{A}$
$I_{GES}$	Gate-emitter leakage current	$V_{CE} = 0 \text{ V}$ , $V_{GE} = \pm 20 \text{ V}$			$\pm 500$	nA
$C_{ies}$	Input capacitance	$V_{CE} = 25 \text{ V}$ , $f = 1 \text{ MHz}$ , $V_{GE} = 0 \text{ V}$		985		pF
$C_{oes}$	Output capacitance			118		pF
$C_{res}$	Reverse transfer capacitance			40		pF
$Q_g$	Total gate charge	$V_{CC} = 960 \text{ V}$ , $I_C = 15 \text{ A}$ , $V_{GE} = \pm 15 \text{ V}$		71		nC
$t_{d(on)}$	Turn-on delay time	$V_{CC} = 600 \text{ V}$ , $I_C = 15 \text{ A}$ , $R_G = 22 \text{ } \Omega$ , $V_{GE} = \pm 15 \text{ V}$ , $di/dt = 820 \text{ A}/\mu\text{s}$		120		ns
$t_r$	Current rise time			14.5		ns
$E_{on(1)}$	Turn-on switching energy			0.59		mJ
$t_{d(off)}$	Turn-off delay time	$V_{CC} = 600 \text{ V}$ , $I_C = 15 \text{ A}$ , $R_G = 22 \text{ } \Omega$ , $V_{GE} = \pm 15 \text{ V}$ , $dv/dt = 8200 \text{ V}/\mu\text{s}$ ;		115		ns
$t_f$	Current fall time			84		ns
$E_{off(2)}$	Turn-off switching energy			0.83		mJ
$t_{d(on)}$	Turn-on delay time	$V_{CC} = 600 \text{ V}$ , $I_C = 15 \text{ A}$ , $R_G = 22 \text{ } \Omega$ , $V_{GE} = \pm 15 \text{ V}$ , $di/dt = 690 \text{ A}/\mu\text{s}$ , $T_J = 150 \text{ }^\circ\text{C}$		122		ns
$t_r$	Current rise time			17		ns
$E_{on}$	Turn-on switching energy			1.08		mJ
$t_{d(off)}$	Turn-off delay time	$V_{CC} = 600 \text{ V}$ , $I_C = 15 \text{ A}$ , $R_G = 22 \text{ } \Omega$ , $V_{GE} = \pm 15 \text{ V}$ , $dv/dt = 7000 \text{ V}/\mu\text{s}$ , $T_J = 150 \text{ }^\circ\text{C}$		122		ns
$t_f$	Current fall time			146		ns
$E_{off}$	Turn-off switching energy			1.06		mJ
$t_{SC}$	Short-circuit withstand time	$V_{CC} \leq 600 \text{ V}$ , $V_{GE} \leq 15 \text{ V}$ , $T_{Jstart} \leq 150 \text{ }^\circ\text{C}$	10			$\mu\text{s}$
$R_{THj-c}$	Thermal resistance junction to case	Each IGBT		0.95	1.05	$^\circ\text{C}/\text{W}$
$R_{THc-h}$	Thermal resistance case to heatsink	Each IGBT, $\lambda_{grease} = 1 \text{ W}/(\text{m}\cdot^\circ\text{C})$		0.90		$^\circ\text{C}/\text{W}$

**Notes:**<sup>(1)</sup>Including the reverse recovery of the diode.<sup>(2)</sup>Including the tail of the collector current.

1.2.2 Diode

Table 8: Absolute maximum ratings of the diode, brake stage

Symbol	Parameter	Value	Unit
V <sub>RRM</sub>	Repetitive peak reverse voltage	1200	V
I <sub>F</sub>	Continuous forward current at (T <sub>C</sub> = 100 °C)	15	A
I <sub>FP</sub> <sup>(1)</sup>	Pulsed forward current	30	A
T <sub>JMAX</sub>	Maximum junction temperature	175	°C
T <sub>Jop</sub>	Operative temperature range under switching conditions	-40 to 150	°C

Notes:

(1)Pulse width limited by maximum junction temperature.

Table 9: Electrical characteristics of the diode, brake stage

Symbol	Parameter	Test conditions	Min.	Typ.	Max.	Unit
V <sub>F</sub>	Forward voltage	I <sub>F</sub> = 15 A	-	3.0	3.8	V
		I <sub>F</sub> = 15 A, T <sub>J</sub> = 150 °C	-	2.1		
t <sub>rr</sub>	Reverse recovery time	I <sub>F</sub> = 15 A, V <sub>R</sub> = 600 V, V <sub>GE</sub> = ±15 V, di/dt = 820 A/μs	-	190		ns
Q <sub>rr</sub>	Reverse recovery charge		-	1.45		μC
I <sub>rrm</sub>	Reverse recovery current		-	23		A
E <sub>rec</sub>	Reverse recovery energy		-	0.55		mJ
t <sub>rr</sub>	Reverse recovery time		I <sub>F</sub> = 15 A, V <sub>R</sub> = 600 V, V <sub>GE</sub> = ±15 V, di/dt = 690 A/μs, T <sub>J</sub> = 150 °C	-	400	
Q <sub>rr</sub>	Reverse recovery charge	-		2.75		μC
I <sub>rrm</sub>	Reverse recovery current	-		25		A
E <sub>rec</sub>	Reverse recovery energy	-		1.2		mJ
R <sub>THj-c</sub>	Thermal resistance junction to case	Each diode		-	1.60	1.75
R <sub>THc-h</sub>	Thermal resistance case to heatsink	Each diode, λ <sub>grease</sub> = 1 W/(m·°C)	-	1.15		°C/W

1.3 Converter stage

Limiting values at T<sub>j</sub> = 25 °C, unless otherwise specified.

Table 10: Absolute maximum ratings of the bridge rectifiers

Symbol	Description	Value	Unit
V <sub>RRM</sub>	Repetitive peak reverse voltage	1600	V
I <sub>F</sub>	RMS forward current	30	A
I <sub>FSM</sub>	Forward surge current tp = 10 ms, T <sub>C</sub> = 25 °C	315	A
	Forward surge current tp = 10 ms, T <sub>C</sub> = 150 °C	250	
I <sup>2</sup> t	tp = 10 ms, T <sub>C</sub> = 25 °C	496	A <sup>2</sup> s
	tp = 10 ms, T <sub>C</sub> = 150 °C	312	
T <sub>JMAX</sub>	Maximum junction temperature	175	°C
T <sub>Jop</sub>	Operative temperature range under switching conditions	-40 to 150	°C

Table 11: Electrical characteristics of the bridge rectifiers

Symbol	Parameter	Test conditions	Min.	Typ.	Max.	Unit
V <sub>F</sub>	Forward voltage	I <sub>F</sub> = 15 A	-	1.0	1.4	V
		I <sub>F</sub> = 15 A, T <sub>J</sub> = 150 °C	-	0.9		
I <sub>R</sub>	Reverse current	T <sub>J</sub> = 150 °C, V <sub>R</sub> = 1600 V	-	1		mA
R <sub>THj-c</sub>	Thermal resistance junction to case	Each diode	-	1.20	1.35	°C/W
R <sub>THc-h</sub>	Thermal resistance case to heatsink	Each diode, λ <sub>grease</sub> = 1 W/(m·°C)	-	1.15		°C/W

## 1.4 NTC

Table 12: NTC temperature sensor, considered as stand-alone

Symbol	Parameter	Test condition	Min.	Typ.	Max.	Unit
R <sub>25</sub>	Resistance	T = 25 °C		5		kΩ
R <sub>100</sub>	Resistance	T = 100 °C		493		Ω
ΔR/R	Deviation of R <sub>100</sub>		-5		+5	%
B <sub>25/50</sub>	B-constant			3375		K
B <sub>25/80</sub>	B-constant			3411		K
T	Operating temperature range		-40		150	°C

Figure 2: NTC resistance vs. temperature

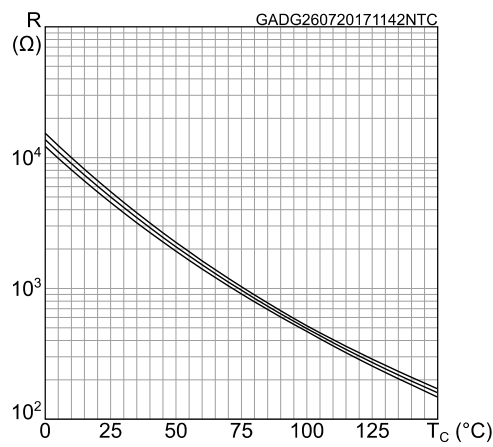
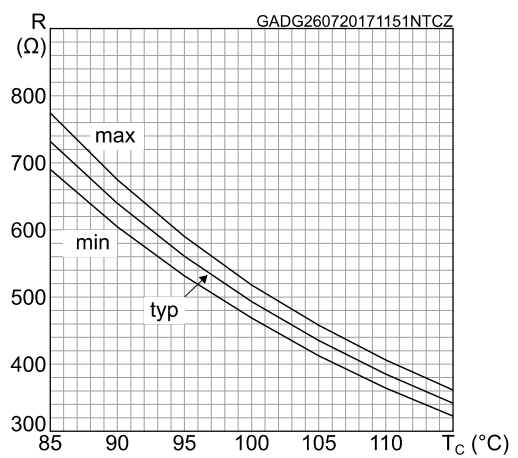

Figure 3: NTC resistance vs. temperature, zoom





## 1.5 Package

Table 13: ACEPACK™ 1 package

Symbol	Parameter	Min.	Typ.	Max.	Unit
V <sub>isol</sub>	Isolation voltage (AC voltage, t = 60 s)			2500	V
M <sub>d</sub>	Screw mounting torque	40		80	Nm
T <sub>stg</sub>	Storage temperature	-40		125	°C
CTI	Comparative tracking index	200			
L <sub>s</sub>	Stray inductance module P1 - EW loop		28.7		nH
R <sub>s</sub>	Module lead resistance, terminal to chip		3.9		mΩ

## 2 Electrical characteristics curves

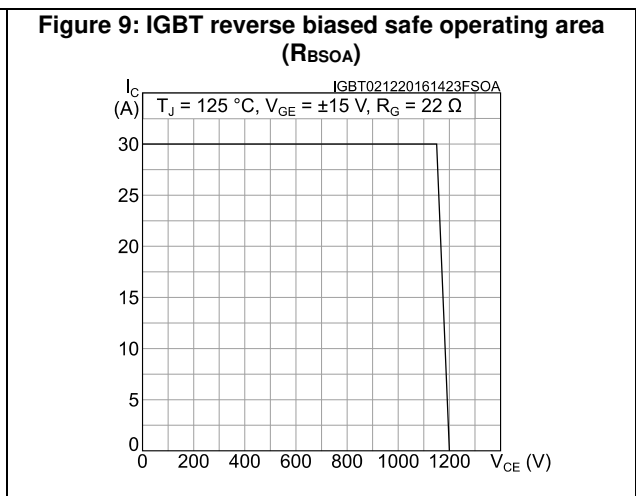
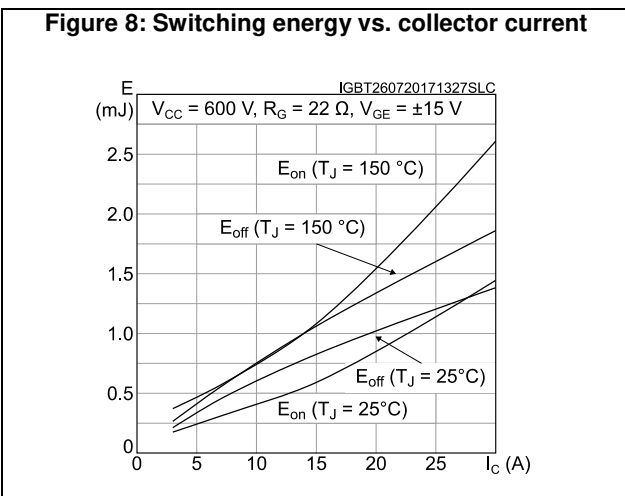
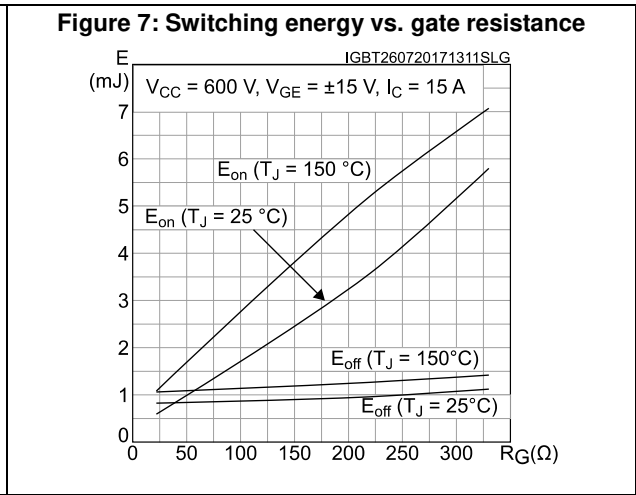
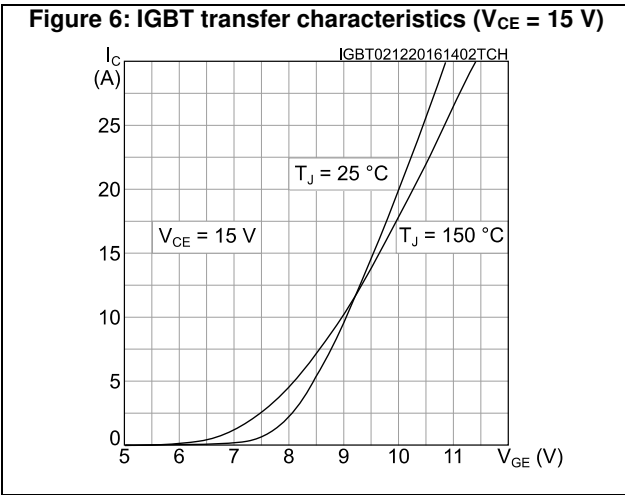
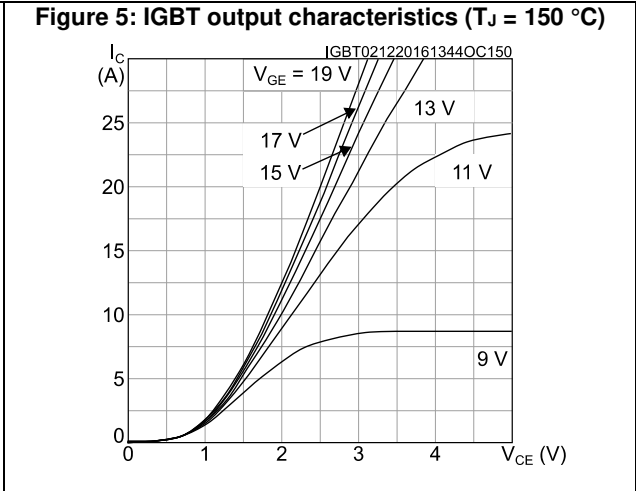
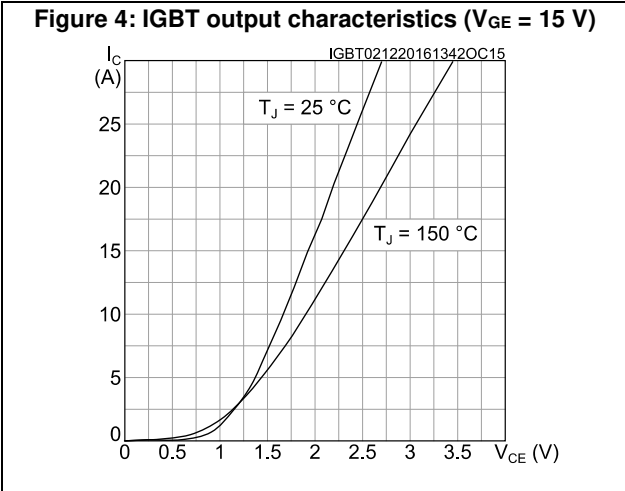

Figure 10: Diode forward characteristics

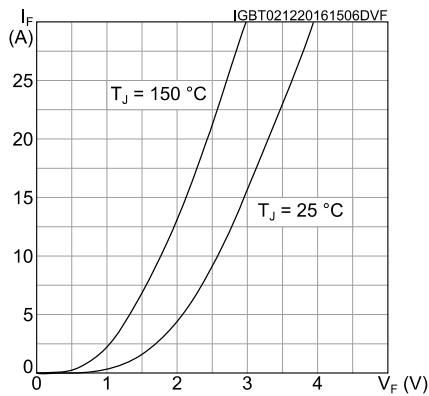

Figure 11: Diode reverse recovery energy vs. diode current slope

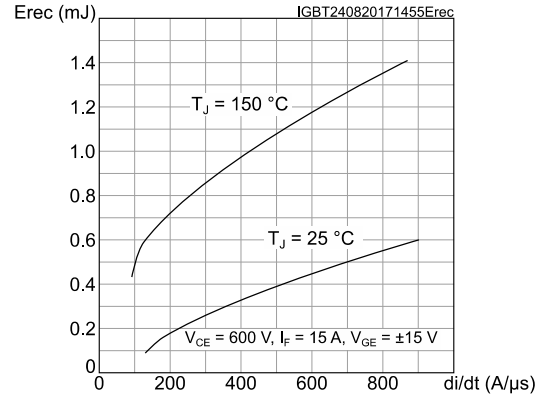

Figure 12: Diode reverse recovery energy vs. forward current

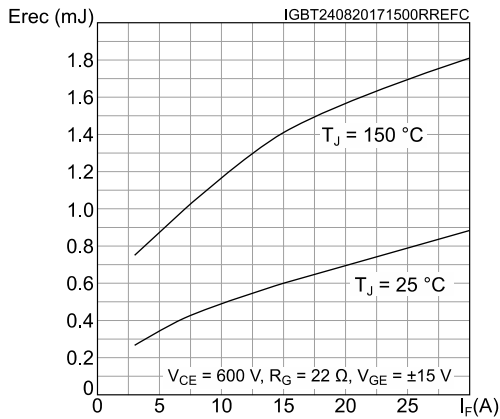

Figure 13: Diode reverse recovery energy vs. gate resistance

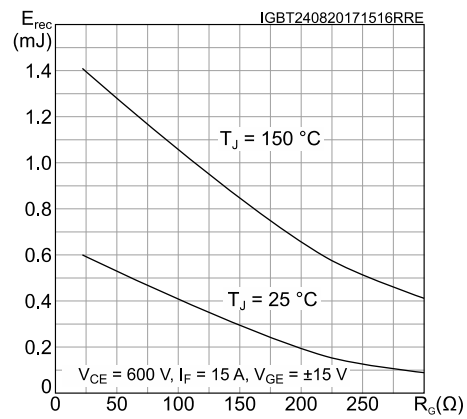

Figure 14: Converter diode forward characteristics

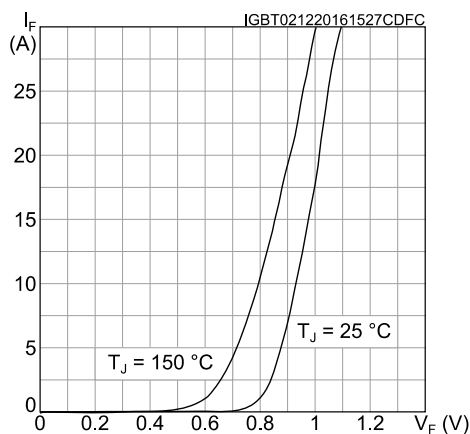

Figure 15: IGBT thermal impedance

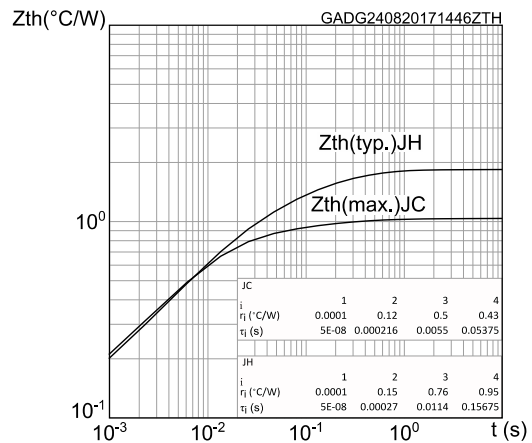
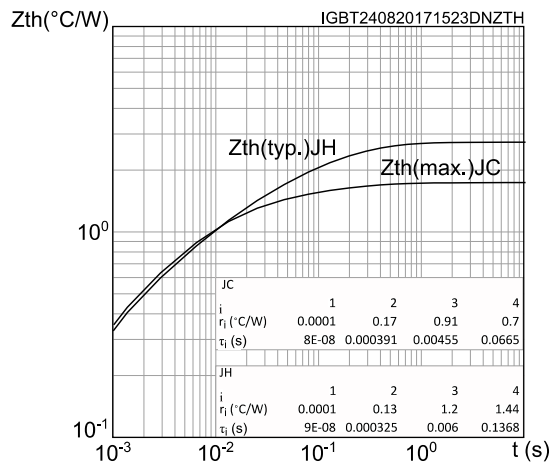
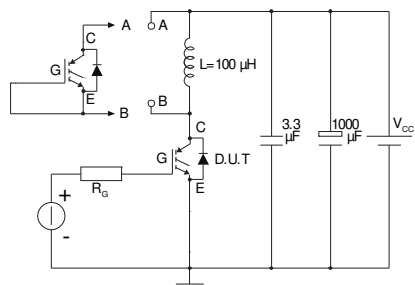

Figure 16: Inverter diode thermal impedance



### 3 Test circuits

**Figure 17: Test circuit for inductive load switching**



AM01504v1

**Figure 18: Gate charge test circuit**

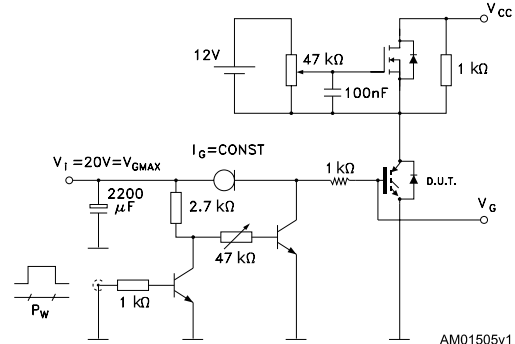

AM01505v1

**Figure 19: Switching waveform**

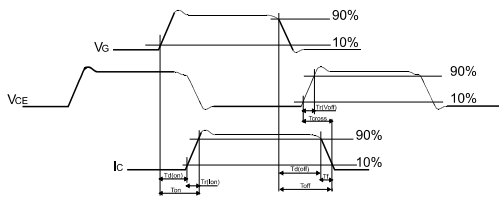

AM01506v1

**Figure 20: Diode reverse recovery waveform**

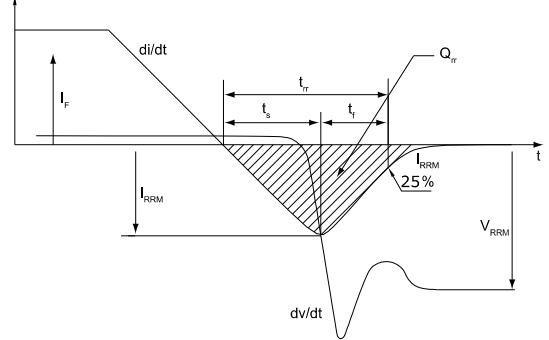

AM01507v1

# 4 Topology and pin description

Figure 21: Electrical topology and pin description

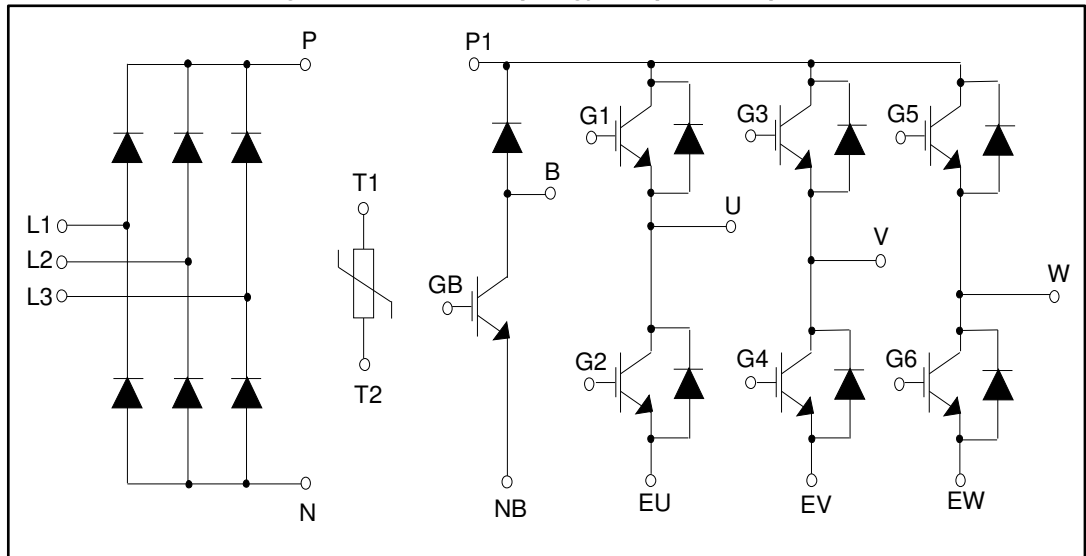
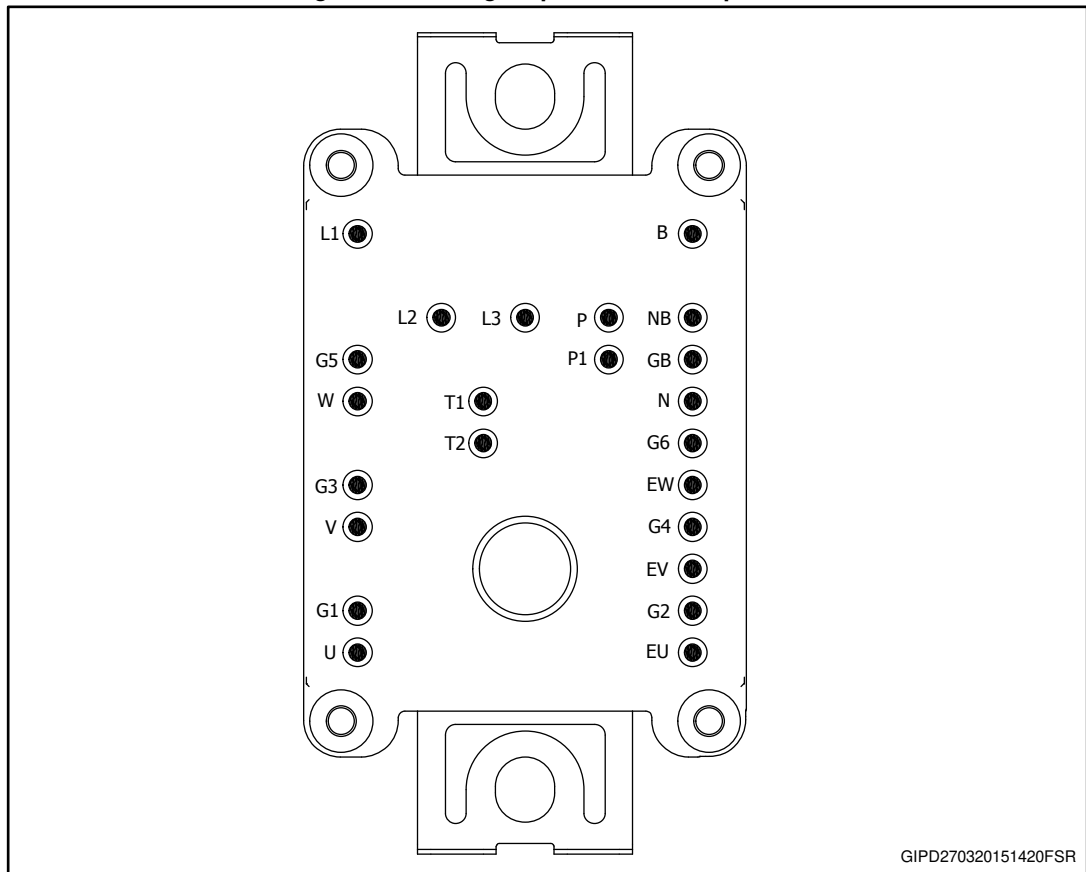

Figure 22: Package top view with CIB pinout



GIPD270320151420FSR

## 5 Package information

In order to meet environmental requirements, ST offers these devices in different grades of ECOPACK® packages, depending on their level of environmental compliance. ECOPACK® specifications, grade definitions and product status are available at: [www.st.com](http://www.st.com). ECOPACK® is an ST trademark.

# 5.1 ACEPACK™ 1 CIB solder pins package information

Figure 23: ACEPACK™ 1 CIB solder pins package outline (dimensions are in mm)

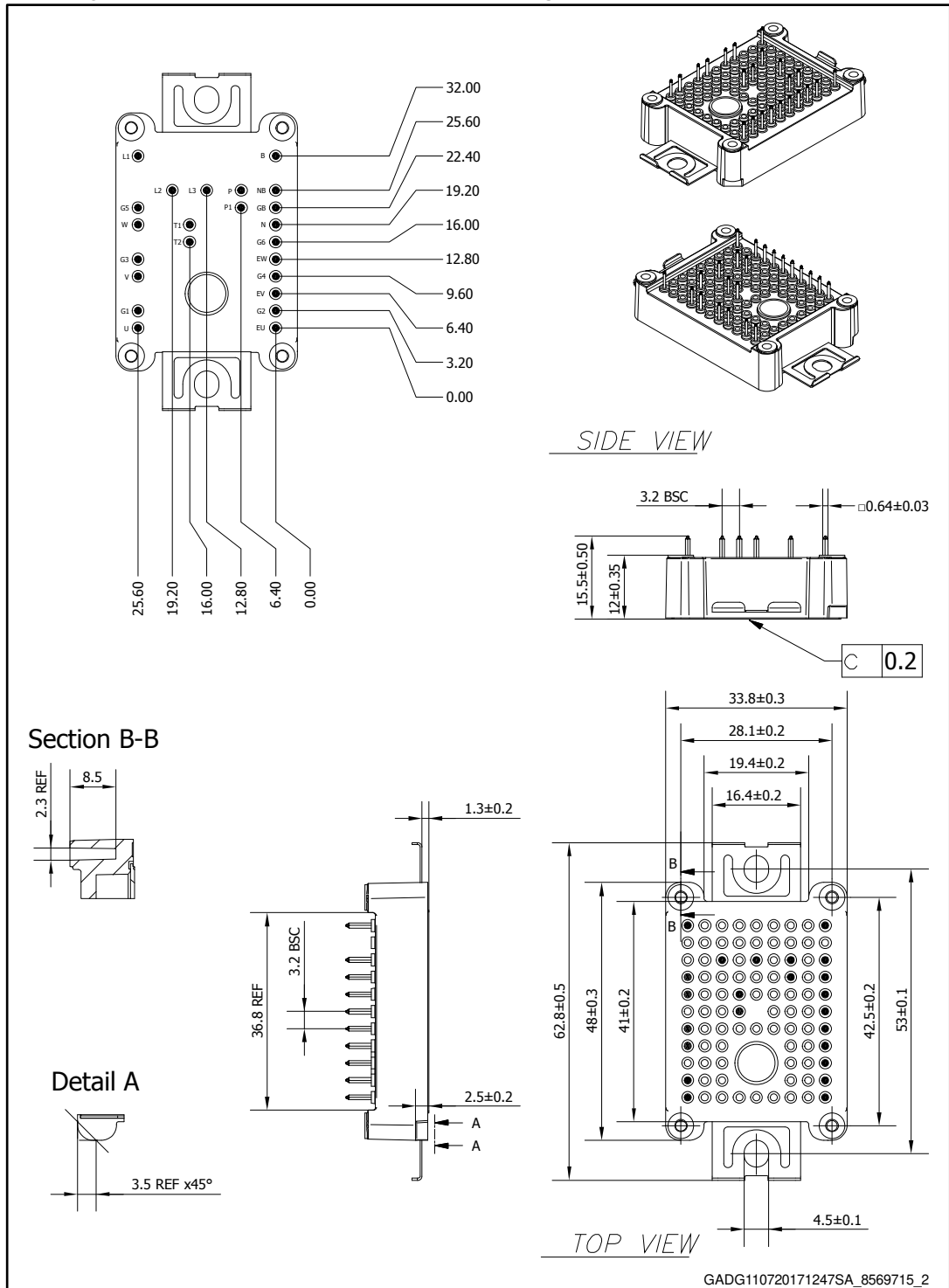

- The lead size includes the thickness of the lead plating material.
- Dimensions do not include mold protrusion.
- Package dimensions do not include any eventual metal burrs.



## 6 Revision history

**Table 14: Document revision history**

Date	Revision	Changes
02-May-2016	1	Initial release.
10-Mar-2017	2	Added <i>Section 2: "Electrical characteristics curves" and Section 3: "Test circuits"</i> . Updated <i>Section 5.1: "ACEPACK™ 1 CIB solder pins package information"</i> . Minor text changes.
26-Jul-2017	3	Datasheet promoted from production data to preliminary data. Modified <i>Table 2: "Absolute maximum ratings of the IGBTs, inverter stage"</i> , <i>Table 3: "Electrical characteristics of the IGBTs, inverter stage"</i> , <i>Table 6: "Absolute maximum ratings of the IGBT, brake stage"</i> , <i>Table 7: "Electrical characteristics of the IGBT, brake stage"</i> , <i>Table 4: "Absolute maximum ratings of the diode, inverter stage"</i> , <i>Table 5: "Electrical characteristics of the diode, inverter stage"</i> , <i>Table 10: "Absolute maximum ratings of the bridge rectifiers"</i> , <i>Table 11: "Electrical characteristics of the bridge rectifiers"</i> , <i>Table 12: "NTC temperature sensor, considered as stand-alone"</i> , <i>Table 13: "ACEPACK™ 1 package"</i> . Modified <i>Figure 10: "IGBT thermal impedance"</i> and. Modified <i>Figure 22: "Package top view with CIB pinout"</i> . Modified <i>Section 5: "Package information"</i> . Minor text changes.
24-Aug-2017	4	Updated <i>Table 3: "Electrical characteristics of the IGBTs, inverter stage"</i> , <i>Table 5: "Electrical characteristics of the diode, inverter stage"</i> , <i>Table 7: "Electrical characteristics of the IGBT, brake stage"</i> , <i>Table 9: "Electrical characteristics of the diode, brake stage"</i> , <i>Table 11: "Electrical characteristics of the bridge rectifiers"</i> , <i>Section 2: "Electrical characteristics curves"</i> . Minor text changes.
05-Oct-2017	5	Updated <i>Table 13: "ACEPACK™ 1 package"</i> , <i>Figure 15: "IGBT thermal impedance"</i> and <i>Figure 16: "Inverter diode thermal impedance"</i> . Minor text changes.

**IMPORTANT NOTICE – PLEASE READ CAREFULLY**

STMicroelectronics NV and its subsidiaries ("ST") reserve the right to make changes, corrections, enhancements, modifications, and improvements to ST products and/or to this document at any time without notice. Purchasers should obtain the latest relevant information on ST products before placing orders. ST products are sold pursuant to ST's terms and conditions of sale in place at the time of order acknowledgement.

Purchasers are solely responsible for the choice, selection, and use of ST products and ST assumes no liability for application assistance or the design of Purchasers' products.

No license, express or implied, to any intellectual property right is granted by ST herein.

Resale of ST products with provisions different from the information set forth herein shall void any warranty granted by ST for such product.

ST and the ST logo are trademarks of ST. All other product or service names are the property of their respective owners.

Information in this document supersedes and replaces information previously supplied in any prior versions of this document.

© 2017 STMicroelectronics – All rights reserved