



# STGD7NB120S-1

N-CHANNEL 7A - 1200V - IPAK

PowerMESH™ IGBT

PRELIMINARY DATA

TYPE	V <sub>CES</sub>	V <sub>CE(sat)</sub>	I <sub>C</sub>
STGD7NB120S-1	1200 V	< 2.1 V	7 A

- HIGH INPUT IMPEDANCE (VOLTAGE DRIVEN)
- VERY LOW ON-VOLTAGE DROP (V<sub>cesat</sub>)
- OFF LOSSES INCLUDE TAIL CURRENT
- HIGH CURRENT CAPABILITY

## DESCRIPTION

Using the latest high voltage technology based on a patented strip layout, STMicroelectronics has designed an advanced family of IGBTs, the PowerMESH™ IGBTs, with outstanding performances. The suffix "S" identifies a family optimized achieve minimum on-voltage drop for low frequency applications (<1kHz).

## APPLICATIONS

- MOTOR CONTROL
- LIGHT DIMMER
- INTRUSH CURRENT LIMITATION

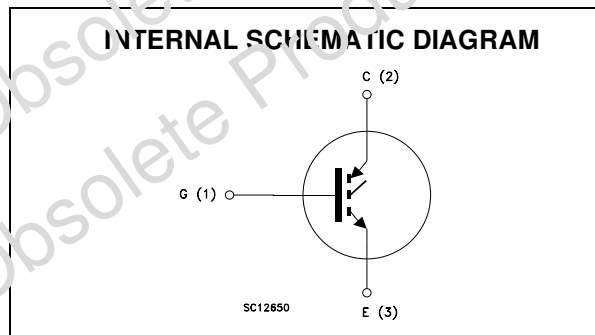
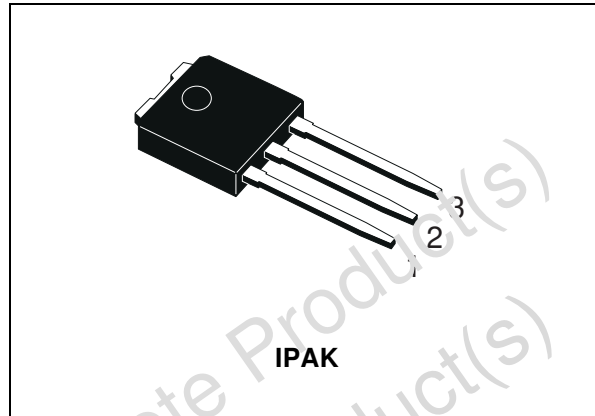

## ABSOLUTE MAXIMUM RATINGS

Symbol	Parameter	Value	Unit
V <sub>CES</sub>	Collector-Emitter Voltage (V <sub>GS</sub> = 0)	1200	V
V <sub>ECR</sub>	Reverse Battery Protection	20	V
V <sub>GE</sub>	Gate-Emitter Voltage	±20	V
I <sub>C</sub>	Collector Current (continuous) at T <sub>C</sub> = 25°C	10	A
I <sub>C</sub>	Collector Current (continuous) at T <sub>C</sub> = 100°C	7	A
I <sub>CM</sub> (●)	Collector Current (pulsed)	20	A
P <sub>TOT</sub>	Total Dissipation at T <sub>C</sub> = 25°C	55	W
	Derating Factor	0.4	W/°C
T <sub>stg</sub>	Storage Temperature	-65 to 150	°C
T <sub>j</sub>	Max. Operating Junction Temperature	150	°C

(●) Pulse width limited by safe operating area

## STGD7NB120S-1

### THERMAL DATA

Rthj-case	Thermal Resistance Junction-case Max	2.27	°C/W
Rthj-amb	Thermal Resistance Junction-ambient Max	100	°C/W
Rthc-h	Thermal Resistance Case-heatsink Typ	0.5	°C/W

### ELECTRICAL CHARACTERISTICS (TCASE = 25 °C UNLESS OTHERWISE SPECIFIED)

OFF

Symbol	Parameter	Test Conditions	Min.	Typ.	Max.	Unit
V <sub>BR(CES)</sub>	Collectro-Emitter Breakdown Voltage	I <sub>C</sub> = 250 μA, V <sub>GE</sub> = 0	1200			V
V <sub>BR(ECR)</sub>	Emitter-Collectro Breakdown Voltage	I <sub>C</sub> = 10mA, V <sub>GE</sub> = 0	20			V
I <sub>CES</sub>	Collector cut-off (V <sub>GE</sub> = 0)	V <sub>CE</sub> = Max Rating, T <sub>C</sub> = 25 °C V <sub>CE</sub> = Max Rating, T <sub>C</sub> = 125 °C			50 250	μA μA
I <sub>GES</sub>	Gate-Emitter Leakage Current (V <sub>CE</sub> = 0)	V <sub>GE</sub> = ±20V, V <sub>CE</sub> = 0			±100	nA

ON (1)

Symbol	Parameter	Test Conditions	Min.	Typ.	Max.	Unit
V <sub>GE(th)</sub>	Gate Threshold Voltage	V <sub>CE</sub> = V <sub>GE</sub> , I <sub>C</sub> = 250μA	3		5	V
V <sub>GE</sub>	Gate Emitter Voltage	V <sub>CE</sub> = 2.5V, I <sub>C</sub> = 2A T <sub>J</sub> = 25±125°C			6.5	V
V <sub>CE(sat)</sub>	Collector-Emitter Saturation Voltage	V <sub>GE</sub> = 15V, I <sub>C</sub> = 3.5 A			1.6	V
		V <sub>CE</sub> = 15V, I <sub>C</sub> = 7 A			2.1	V
		V <sub>GE</sub> = 15V, I <sub>C</sub> = 10 A		1.7		

### DYNAMIC

Symbol	Parameter	Test Conditions	Min.	Typ.	Max.	Unit
g <sub>fs</sub>	Forward Transconductance	V <sub>CE</sub> = 25 V, I <sub>C</sub> = 7 A	2.5	4.5		S
C <sub>ies</sub>	Input Capacitance	V <sub>CE</sub> = 25V, f = 1 MHz, V <sub>GE</sub> = 0		430		pF
C <sub>oes</sub>	Output Capacitance			40		pF
C <sub>res</sub>	Reverse Transfer Capacitance			7		pF
Q <sub>g</sub>	Gate Charge	V <sub>CE</sub> = 960V, I <sub>C</sub> = 7 A, V <sub>GE</sub> = 15V		29		nC
I <sub>CL</sub>	Latching Current	V <sub>clamp</sub> = 960V, T <sub>J</sub> = 150°C R <sub>G</sub> = 1KΩ	10			A

### SWITCHING ON

Symbol	Parameter	Test Conditions	Min.	Typ.	Max.	Unit
t <sub>d(on)</sub>	Turn-on Delay Time	V <sub>CC</sub> = 960 V, I <sub>C</sub> = 7 A R <sub>G</sub> = 1KΩ, V <sub>GE</sub> = 15 V		570		ns
t <sub>r</sub>	Rise Time			270		ns
(di/dt) <sub>on</sub>	Turn-on Current Slope	V <sub>CC</sub> = 960 V, I <sub>C</sub> = 7 A, R <sub>G</sub> = 1KΩ V <sub>GE</sub> = 15 V, T <sub>J</sub> = 125°C		800		A/μs
E <sub>on</sub>	Turn-on Switching Losses			3.2		μJ

**ELECTRICAL CHARACTERISTICS (CONTINUED)****SWITCHING OFF**

Symbol	Parameter	Test Conditions	Min.	Typ.	Max.	Unit
$t_c$	Cross-over Time	$V_{CC} = 960 \text{ V}$ , $I_C = 7 \text{ A}$ , $R_{GE} = 1 \text{ K}\Omega$ , $V_{GE} = 15 \text{ V}$		4.9		$\mu\text{s}$
$t_r(V_{off})$	Off Voltage Rise Time			2.9		$\mu\text{s}$
$t_f$	Fall Time			3.3		$\mu\text{s}$
$E_{off(**)}$	Turn-off Switching Loss			15		mJ
$t_c$	Cross-over Time	$V_{CC} = 960 \text{ V}$ , $I_C = 7 \text{ A}$ , $R_{GE} = 1 \text{ K}\Omega$ , $V_{GE} = 15 \text{ V}$ $T_j = 125 \text{ }^\circ\text{C}$		7.5		$\mu\text{s}$
$t_r(V_{off})$	Off Voltage Rise Time			5.5		$\mu\text{s}$
$t_f$	Fall Time			6.2		$\mu\text{s}$
$E_{off(**)}$	Turn-off Switching Loss			22		mJ

Note: 1. Pulsed: Pulse duration = 300  $\mu\text{s}$ , duty cycle 1.5 %.

2. Pulse width limited by max. junction temperature.

(\*\*) Losses include Also the Tail (Jedec Standardization)

Fig. 1: Gate Charge test Circuit

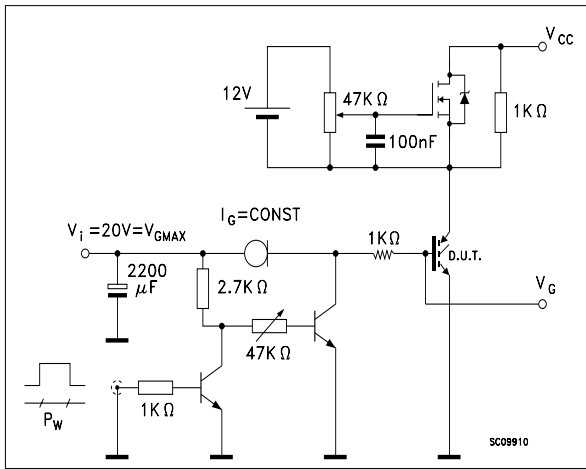
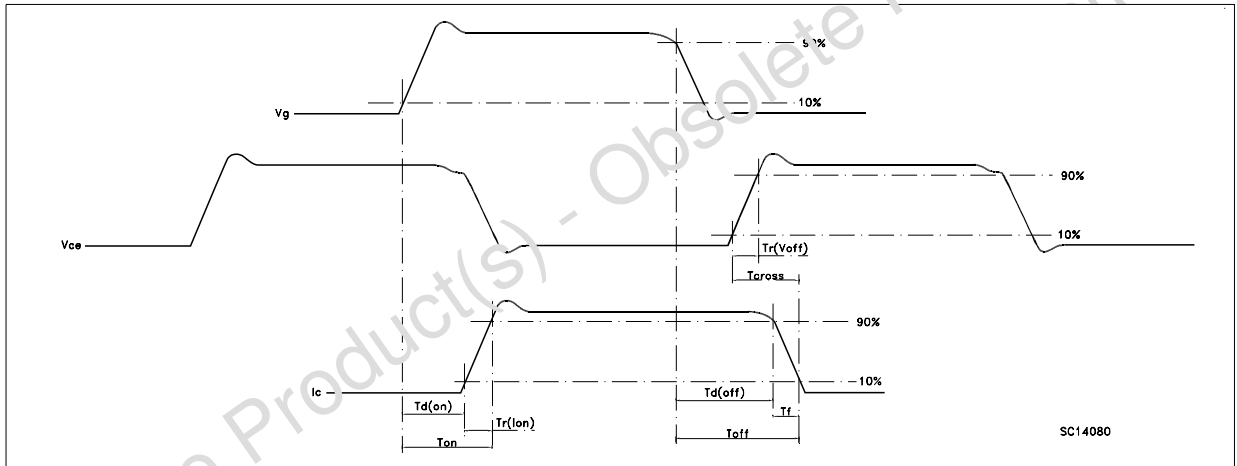
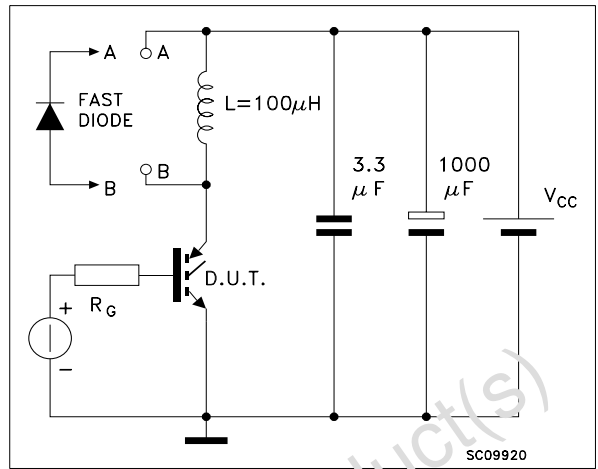
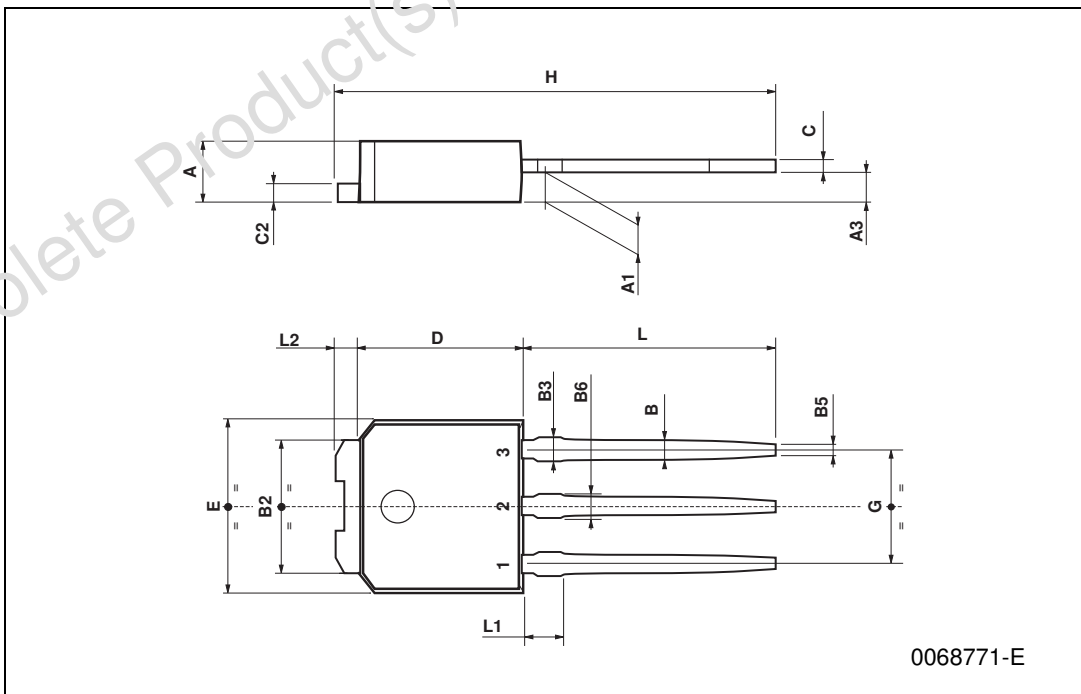

Fig. 2: Test Circuit For Inductive Load Switching



**TO-251 (IPAK) MECHANICAL DATA**

DIM.	mm			inch		
	MIN.	TYP.	MAX.	MIN.	TYP.	MAX.
A	2.2		2.4	0.086		0.094
A1	0.9		1.1	0.035		0.043
A3	0.7		1.3	0.027		0.051
B	0.64		0.9	0.025		0.031
B2	5.2		5.4	0.204		0.212
B3			0.85			0.033
B5		0.3			0.012	
B6			0.95			0.037
C	0.45		0.6	0.017		0.023
C2	0.48		0.6	0.019		0.023
D	6		6.2	0.236		0.244
E	6.4		6.6	0.252		0.260
G	4.4		4.6	0.173		0.181
H	15.9		16.3	0.626		0.641
L	9		9.1	0.354		0.370
L1	0.8		1	0.031		0.047
L2		0.8	1		0.031	0.039



0068771-E

Obsolete Product(s) - Obsolete Product(s)

Information furnished is believed to be accurate and reliable. However, STMicroelectronics assumes no responsibility for the consequences of use of such information nor for any infringement of patents or other rights of third parties which may result from its use. No license is granted by implication or otherwise under any patent or patent rights of STMicroelectronics. Specification mentioned in this publication are subject to change without notice. This publication supersedes and replaces all information previously supplied. STMicroelectronics products are not authorized for use as critical components in life support devices or systems without express written approval of STMicroelectronics.

The ST logo is a trademark of STMicroelectronics

© 2000 STMicroelectronics – Printed in Italy – All Rights Reserved  
STMicroelectronics GROUP OF COMPANIES

Australia - Brazil - China - Finland - France - Germany - Hong Kong - India - Italy - Japan - Malaysia - Malta - Morocco -  
Singapore - Spain - Sweden - Switzerland - United Kingdom - U.S.A.

<http://www.st.com>