



STGP12NB60KD - STGB12NB60KD

N-CHANNEL 18A - 600V TO-220/D²PAK
SHORT CIRCUIT PROOF PowerMESH™ IGBT

TYPE	V _{CES}	V _{CE(sat)} (Max) @25°C	I _C (#) @ 100°C
STGP12NB60KD	600 V	< 2.8 V	18 A
STGB12NB60KD	600 V	< 2.8 V	18 A

- HIGH INPUT IMPEDANCE
- LOW ON-LOSSES
- LOW GATE CHARGE
- HIGH CURRENT CAPABILITY
- OFF LOSSES INCLUDE TAIL CURRENT
- VERY HIGH FREQUENCY OPERATION
- TYPICAL SHORT CIRCUIT WITHSTAND TIME 10 MICROS
- CO-PACKAGED ANTIPARALLEL DIODE

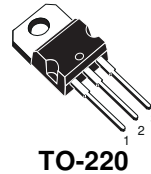

DESCRIPTION

Using the latest high voltage technology based on a patented strip layout, STMicroelectronics has designed an advanced family of IGBTs, the PowerMESH™ IGBTs, with outstanding performances. The suffix "K" identifies a family optimized for high frequency applications (up to 50kHz) and short circuit proof in order to achieve very high switching performances (reduced t_{fall}) maintaining a low voltage drop.

APPLICATIONS

- HIGH FREQUENCY MOTOR CONTROLS
- SMPS
- UPS

INTERNAL SCHEMATIC DIAGRAM

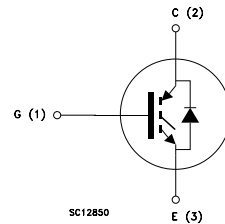

ORDERING INFORMATION

SALES TYPE	MARKING	PACKAGE	PACKAGING
STGP12NB60KD	GP12NB60KD	TO-220	TUBE
STGB12NB60KDT4	GB12NB60KD	D ² PAK	TAPE & REEL

STGP12NB60KD - STGB12NB60KD

ABSOLUTE MAXIMUM RATINGS

Symbol	Parameter	Value	Unit
V_{CES}	Collector-Emitter Voltage ($V_{GS} = 0$)	600	V
V_{ECR}	Emitter-Collector Voltage	20	V
V_{GE}	Gate-Emitter Voltage	± 20	V
I_C	Collector Current (continuous) at $T_C = 25^\circ\text{C}$ (#)	30	A
I_C	Collector Current (continuous) at $T_C = 100^\circ\text{C}$ (#)	18	A
$I_{CM}(\bullet)$	Collector Current (pulsed)	60	A
T_{sc}	Short Circuit Withstand	10	μs
P_{TOT}	Total Dissipation at $T_C = 25^\circ\text{C}$	125	W
	Derating Factor	1.0	W/ $^\circ\text{C}$
T_{stg}	Storage Temperature	-65 to 150	$^\circ\text{C}$
T_j	Max. Operating Junction Temperature	150	$^\circ\text{C}$

(•) Pulse width limited by safe operating area

THERMAL DATA

Rthj-case	Thermal Resistance Junction-case Max	1.0	$^\circ\text{C}/\text{W}$
Rthj-amb	Thermal Resistance Junction-ambient Max	62.5	$^\circ\text{C}/\text{W}$

ELECTRICAL CHARACTERISTICS ($T_{CASE} = 25^\circ\text{C}$ UNLESS OTHERWISE SPECIFIED)

OFF

Symbol	Parameter	Test Conditions	Min.	Typ.	Max.	Unit
$V_{BR}(CES)$	Collector-Emitter Breakdown Voltage	$I_C = 250 \mu\text{A}$, $V_{GE} = 0$	600			V
I_{CES}	Collector cut-off ($V_{GE} = 0$)	$V_{CE} = \text{Max Rating}$, $T_C = 25^\circ\text{C}$ $V_{CE} = \text{Max Rating}$, $T_C = 125^\circ\text{C}$			50 100	μA μA
I_{GES}	Gate-Emitter Leakage Current ($V_{CE} = 0$)	$V_{GE} = \pm 20\text{V}$, $V_{CE} = 0$			± 100	nA

ON (1)

Symbol	Parameter	Test Conditions	Min.	Typ.	Max.	Unit
$V_{GE(th)}$	Gate Threshold Voltage	$V_{CE} = V_{GE}$, $I_C = 250 \mu\text{A}$	5		7	V
$V_{CE(sat)}$	Collector-Emitter Saturation Voltage	$V_{GE} = 15\text{V}$, $I_C = 12\text{A}$ $V_{GE} = 15\text{V}$, $I_C = 12\text{A}$, $T_j = 125^\circ\text{C}$		2.2 1.7	2.8	V V

DYNAMIC

Symbol	Parameter	Test Conditions	Min.	Typ.	Max.	Unit
g_{fs}	Forward Transconductance	$V_{CE} = 25\text{V}$, $I_C = 12\text{A}$		5		S
C_{ies} C_{oes} C_{res}	Input Capacitance Output Capacitance Reverse Transfer Capacitance	$V_{CE} = 25\text{V}$, $f = 1\text{MHz}$, $V_{GE} = 0$		890 110 22		pF pF pF
Q_g Q_{ge} Q_{gc}	Total Gate Charge Gate-Emitter Charge Gate-Collector Charge	$V_{CE} = 480\text{V}$, $I_C = 12\text{A}$, $V_{GE} = 15\text{V}$		54 8 31		nC nC nC
I_{CL}	Latching Current	$V_{clamp} = 480\text{V}$, $V_{GE} = 15\text{V}$, $T_j = 125^\circ\text{C}$, $R_G = 10\ \Omega$		48		A
T_{wsc}	Short Circuit WITHSTAND Time	$V_{CE} = 0.5 BV_{ces}$, $V_{GE} = 15\text{V}$ $T_j = 125^\circ\text{C}$, $R_G = 10\ \Omega$	10			μs

ELECTRICAL CHARACTERISTICS (CONTINUED)

SWITCHING ON

Symbol	Parameter	Test Conditions	Min.	Typ.	Max.	Unit
$t_{d(on)}$	Turn-on Delay Time	$V_{CC} = 480\text{ V}, I_C = 12\text{ A}$ $R_G = 10\Omega, V_{GE} = 15\text{ V}$		25		ns
t_r	Rise Time			14.5		ns
$(di/dt)_{on}$	Turn-on Current Slope	$V_{CC} = 480\text{ V}, I_C = 12\text{ A}, R_G = 10\Omega$ $V_{GE} = 15\text{ V}, T_j = 125^\circ\text{C}$		590		A/ μs
E_{on}	Turn-on Switching Losses			180		μJ

SWITCHING OFF

Symbol	Parameter	Test Conditions	Min.	Typ.	Max.	Unit
t_c	Cross-over Time	$V_{CC} = 480\text{ V}, I_C = 12\text{ A},$ $R_{GE} = 10\Omega, V_{GE} = 15\text{ V}$		130		ns
$t_r(V_{off})$	Off Voltage Rise Time			25		ns
$t_{d(off)}$	Delay Time			96		ns
t_f	Fall Time			100		ns
$E_{off(**)}$	Turn-off Switching Loss			258		μJ
E_{ts}	Total Switching Loss			410		μJ
t_c	Cross-over Time	$V_{CC} = 480\text{ V}, I_C = 12\text{ A},$ $R_{GE} = 10\Omega, V_{GE} = 15\text{ V}$ $T_j = 125^\circ\text{C}$		310		ns
$t_r(V_{off})$	Off Voltage Rise Time			80		ns
$t_{d(off)}$	Delay Time			150		ns
t_f	Fall Time			220		ns
$E_{off(**)}$	Turn-off Switching Loss			650		μJ
E_{ts}	Total Switching Loss			830		μJ

Note: 1. Pulsed: Pulse duration = 300 μs , duty cycle 1.5 %.
 2. Pulse width limited by max. junction temperature.
 (**) Losses include Also the Tail (Jedec Standardization)

COLLECTOR-EMITTER DIODE

Symbol	Parameter	Test Conditions	Min.	Typ.	Max.	Unit
I_f	Forward Current				12	A
I_{fm}	Forward Current pulsed				48	A
V_f	Forward On-Voltage	$I_f = 6\text{ A}$ $I_f = 6\text{ A}, T_j = 125^\circ\text{C}$		1.3 1.1	1.9	V V
t_{rr}	Reverse Recovery Time	$I_f = 6\text{ A}, V_R = 50\text{ V},$ $T_j = 125^\circ\text{C}, di/dt = 100\text{ A}/\mu\text{s}$		80		ns
Q_{rr}	Reverse Recovery Charge			240		nC
I_{rrm}	Reverse Recovery Current			5.5		A

(#) Calculated according to the iterative formula:

$$I_C(T_C) = \frac{T_{JMAX} - T_C}{R_{THJ-C} \times V_{CESAT(MAX)}(T_C, I_C)}$$

STGP12NB60KD - STGB12NB60KD

Output Characteristics

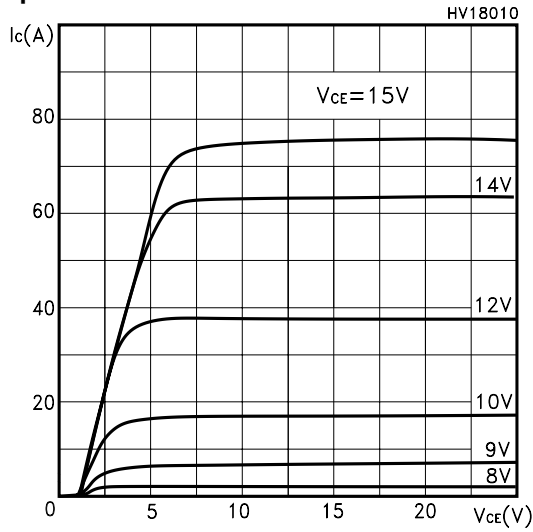

Transfer Characteristics

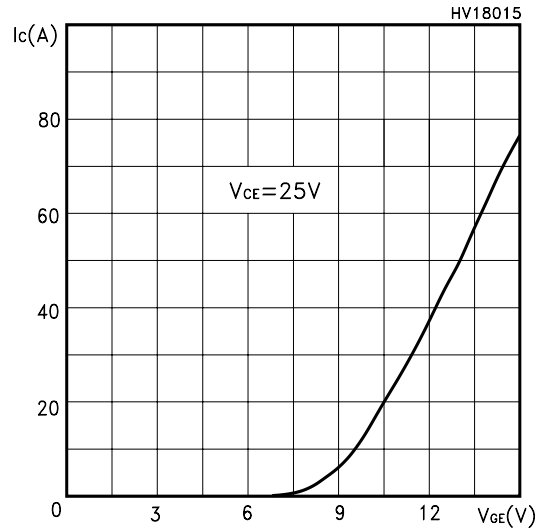

Transconductance

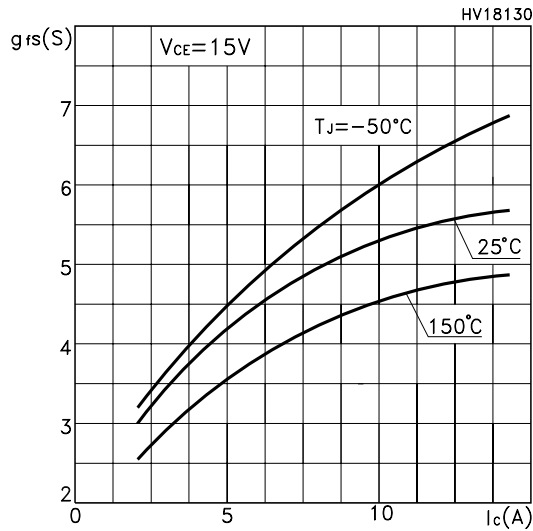

Normalized Collector-Emitter On Voltage vs Temp.

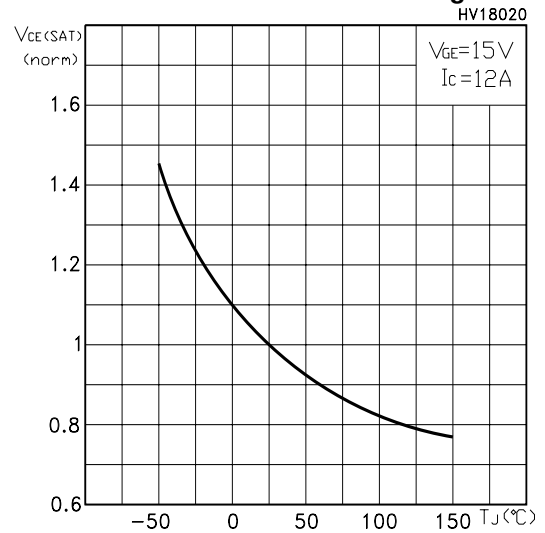

Collector-Emitter On Voltage vs Temperature

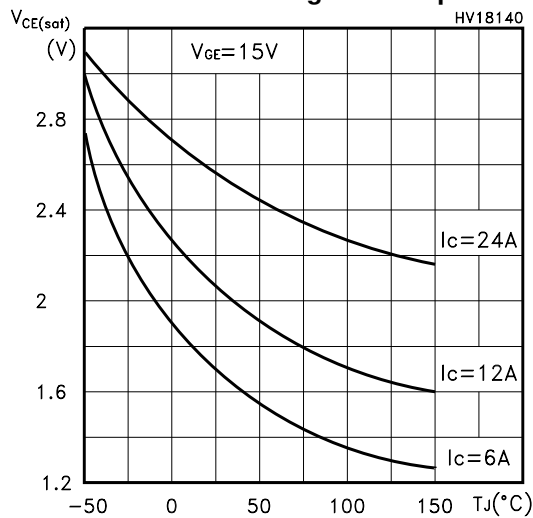

Collector-Emitter On Voltage vs Collector Current

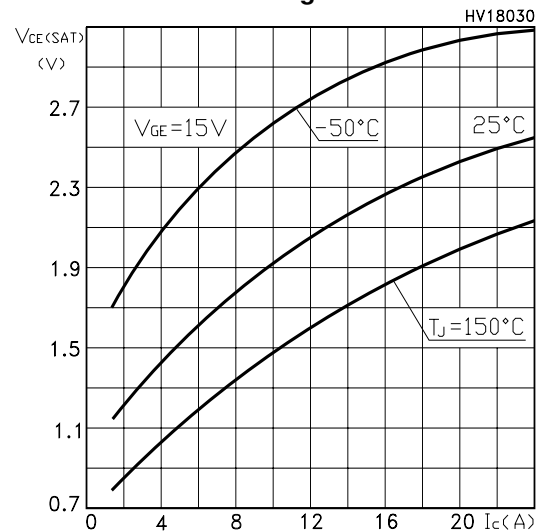

Gate Threshold vs Temperature

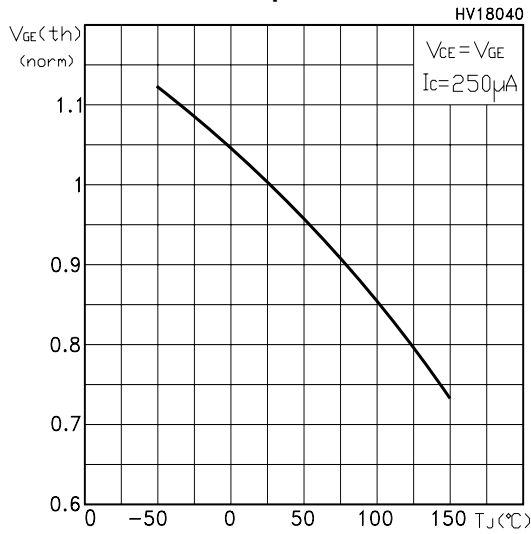

Normalized Breakdown Voltage vs Temperature

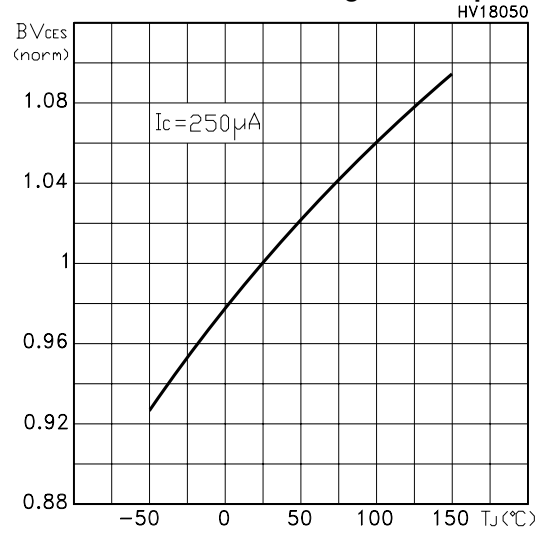

Capacitance Variations

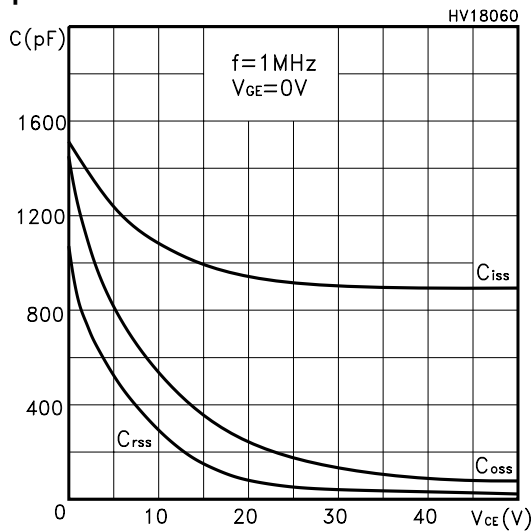

Gate Charge vs Gate-Emitter Voltage

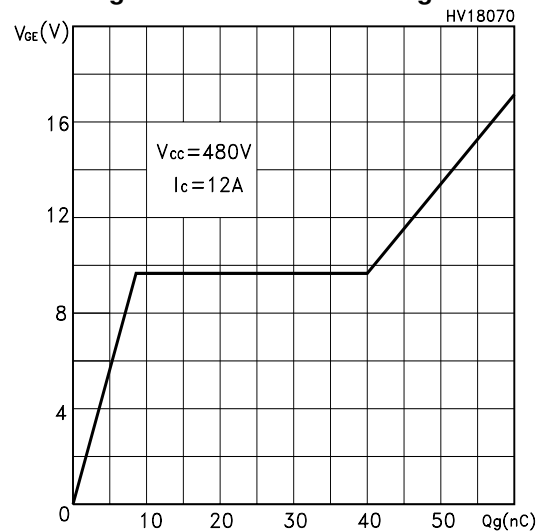

Total Switching Losses vs Gate Resistance

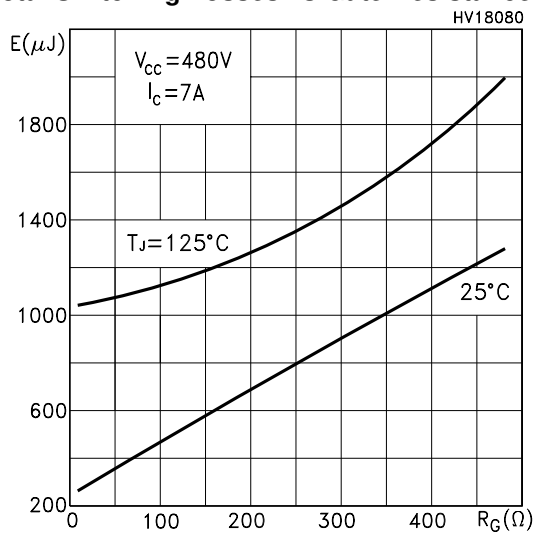

Total Switching Losses vs Temperature

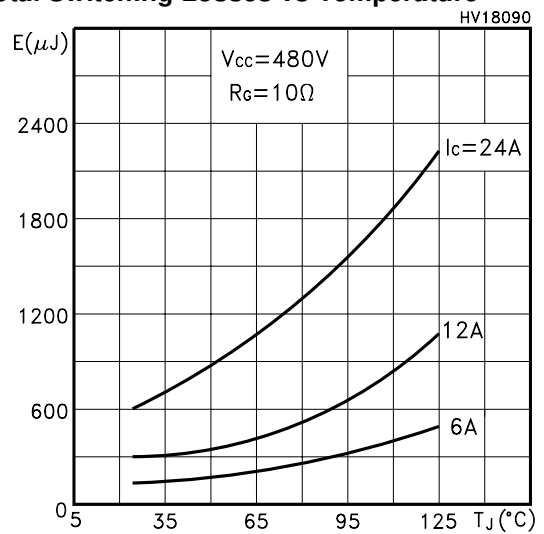

STGP12NB60KD - STGB12NB60KD

Total Switching Losses vs Collector Current

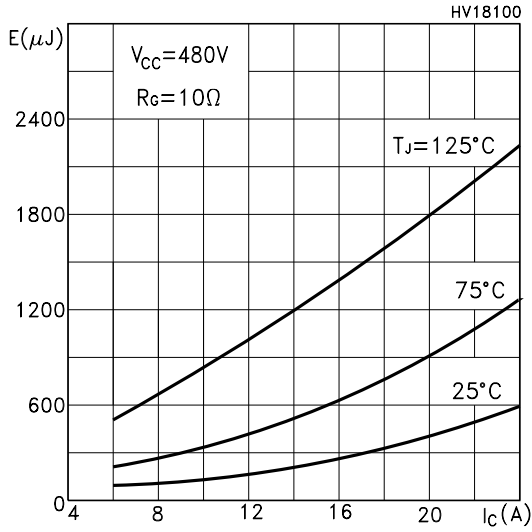

Diode Forward Voltage

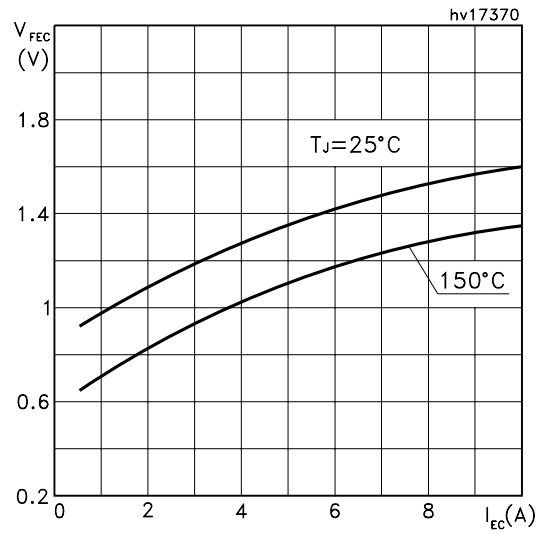

Turn-Off SOA

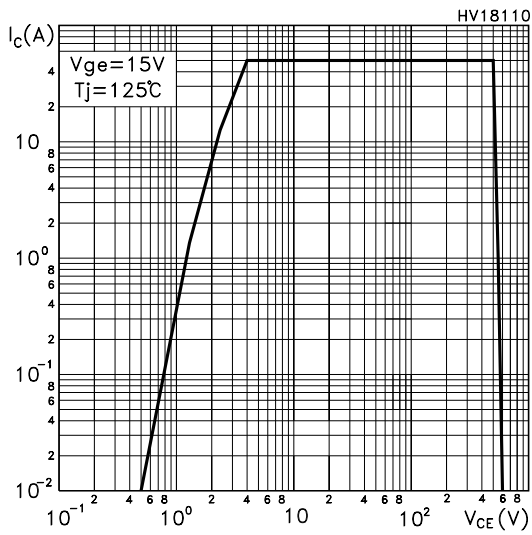

Thermal Impedance

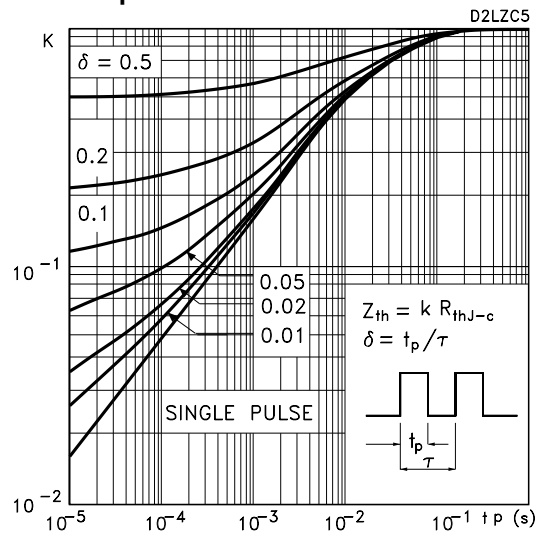

Fig. 1: Gate Charge test Circuit

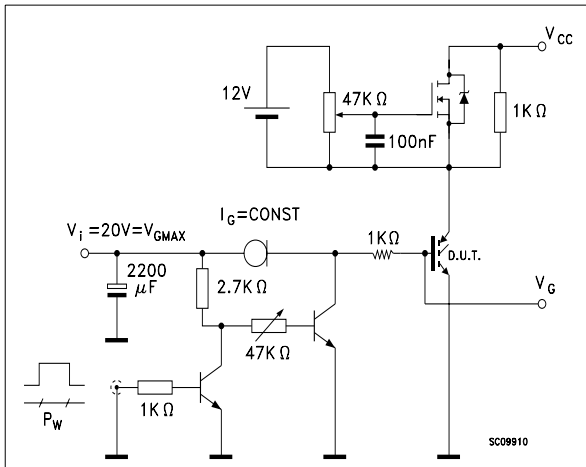
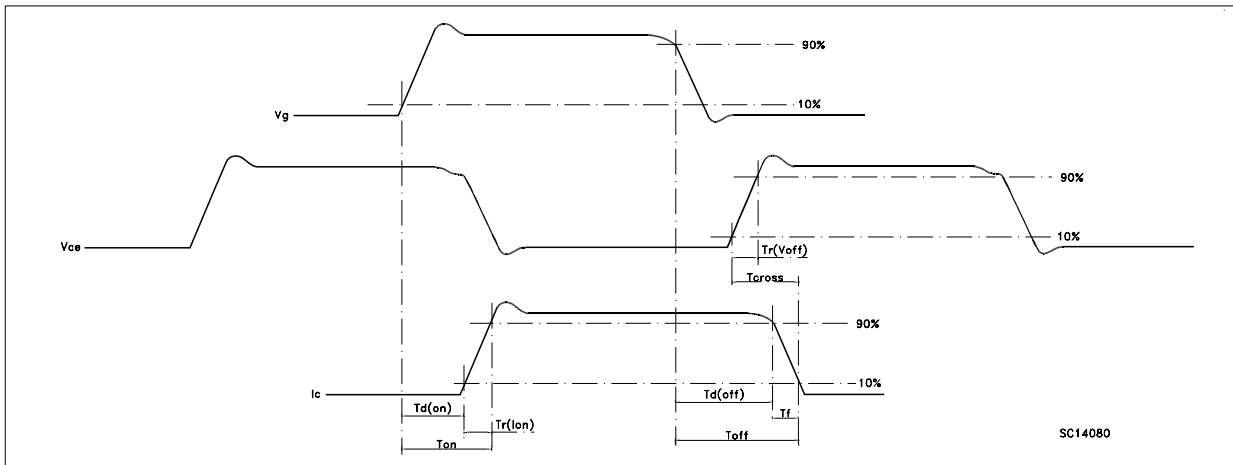
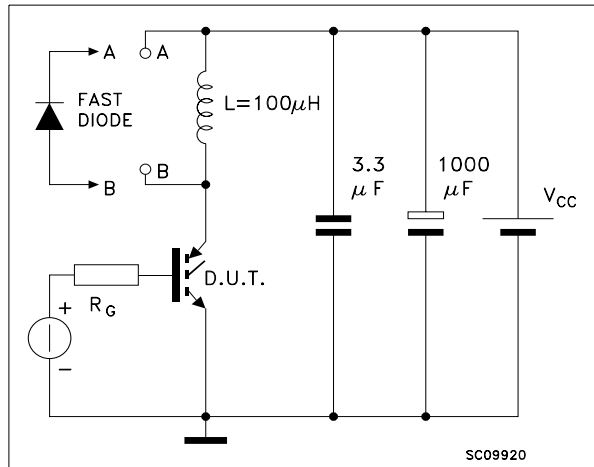
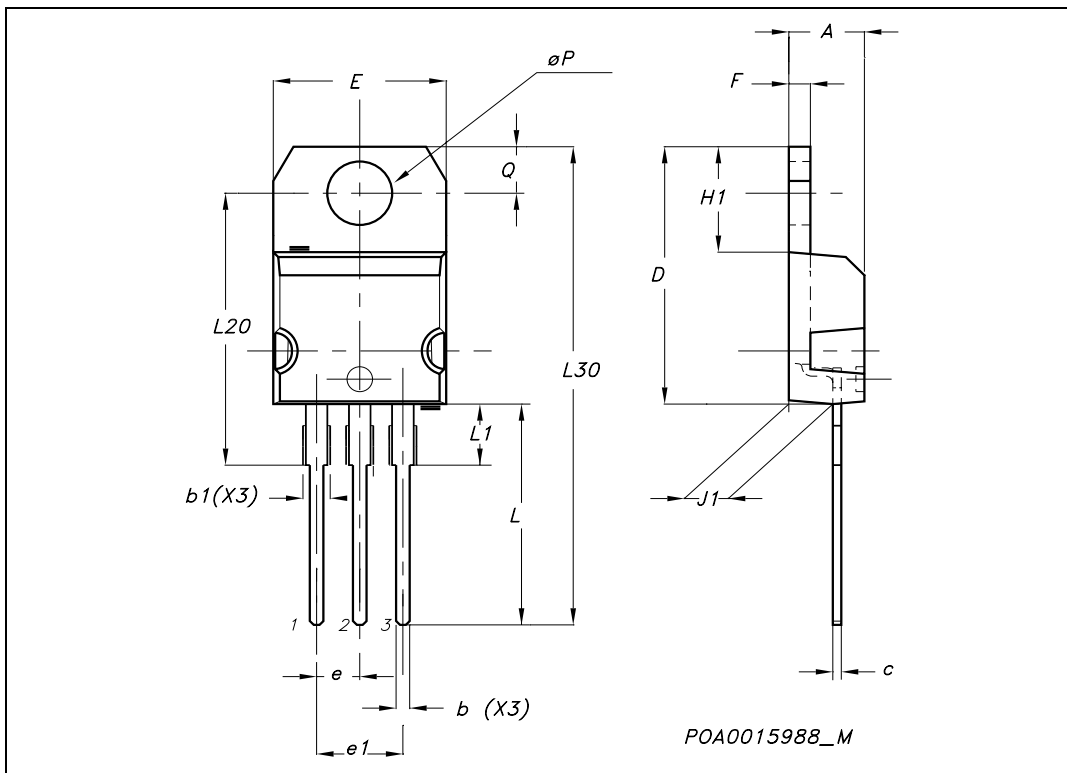

Fig. 2: Test Circuit For Inductive Load Switching



TO-220 MECHANICAL DATA

DIM.	mm.			inch		
	MIN.	TYP	MAX.	MIN.	TYP.	MAX.
A	4.40		4.60	0.173		0.181
b	0.61		0.88	0.024		0.034
b1	1.15		1.70	0.045		0.066
c	0.49		0.70	0.019		0.027
D	15.25		15.75	0.60		0.620
E	10		10.40	0.393		0.409
e	2.40		2.70	0.094		0.106
e1	4.95		5.15	0.194		0.202
F	1.23		1.32	0.048		0.052
H1	6.20		6.60	0.244		0.256
J1	2.40		2.72	0.094		0.107
L	13		14	0.511		0.551
L1	3.50		3.93	0.137		0.154
L20		16.40			0.645	
L30		28.90			1.137	
øP	3.75		3.85	0.147		0.151
Q	2.65		2.95	0.104		0.116



D²PAK MECHANICAL DATA

DIM.	mm.			inch		
	MIN.	TYP	MAX.	MIN.	TYP.	MAX.
A	4.4		4.6	0.173		0.181
A1	2.49		2.69	0.098		0.106
A2	0.03		0.23	0.001		0.009
B	0.7		0.93	0.027		0.036
B2	1.14		1.7	0.044		0.067
C	0.45		0.6	0.017		0.023
C2	1.23		1.36	0.048		0.053
D	8.95		9.35	0.352		0.368
D1		8			0.315	
E	10		10.4	0.393		
E1		8.5			0.334	
G	4.88		5.28	0.192		0.208
L	15		15.85	0.590		0.625
L2	1.27		1.4	0.050		0.055
L3	1.4		1.75	0.055		0.068
M	2.4		3.2	0.094		0.126
R		0.4			0.015	
V2	0°		8°			

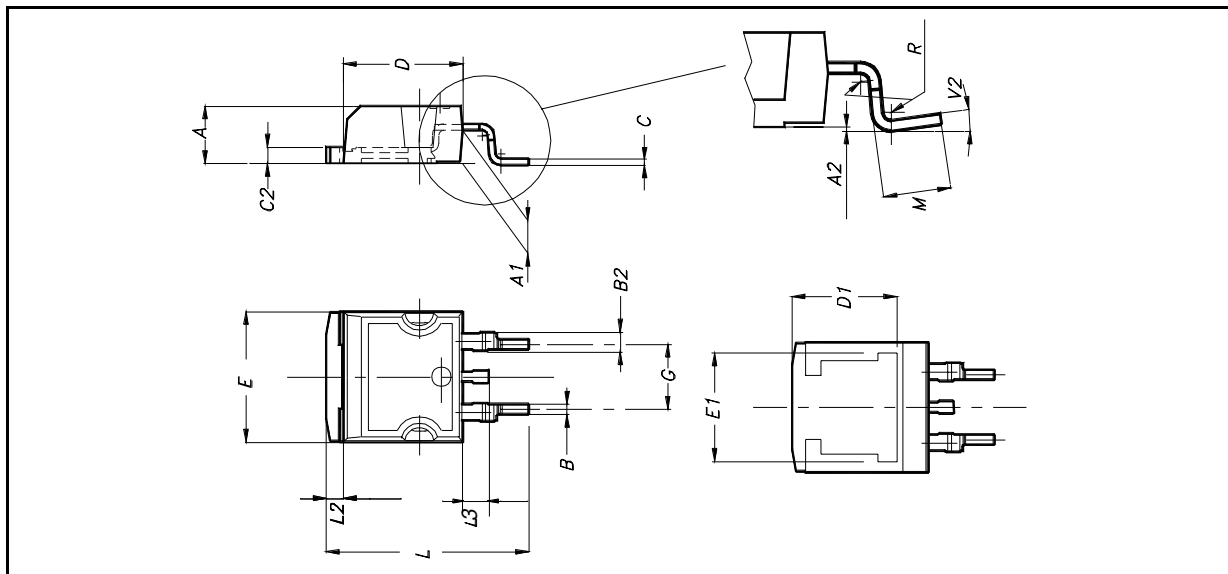

D²PAK FOOTPRINT

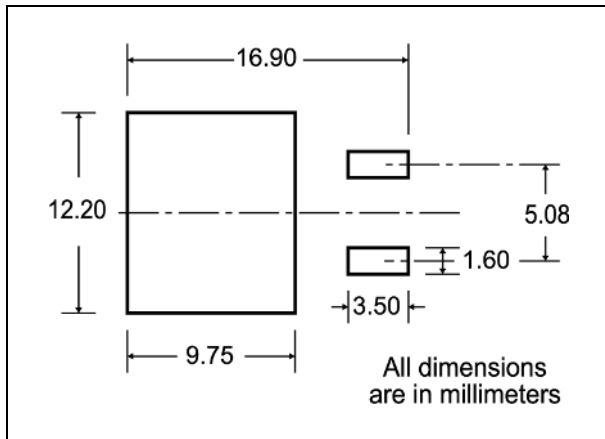

TUBE SHIPMENT (no suffix)*

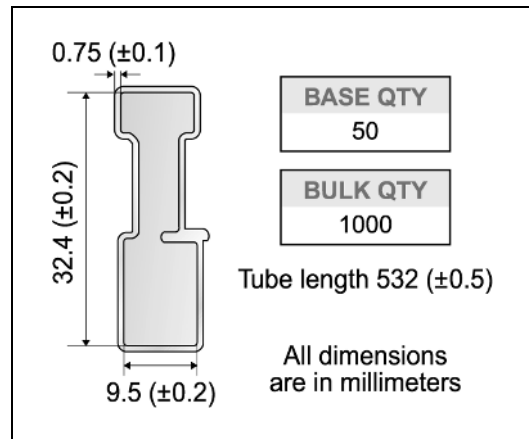

TAPE AND REEL SHIPMENT (suffix "T4")*

TAPE MECHANICAL DATA

DIM.	mm		inch	
	MIN.	MAX.	MIN.	MAX.
A0	10.5	10.7	0.413	0.421
B0	15.7	15.9	0.618	0.626
D	1.5	1.6	0.059	0.063
D1	1.59	1.61	0.062	0.063
E	1.65	1.85	0.065	0.073
F	11.4	11.6	0.449	0.456
K0	4.8	5.0	0.189	0.197
P0	3.9	4.1	0.153	0.161
P1	11.9	12.1	0.468	0.476
P2	1.9	2.1	0.075	0.082
R	50		1.574	
T	0.25	0.35	0.0098	0.0137
W	23.7	24.3	0.933	0.956

REEL MECHANICAL DATA

DIM.	mm		inch	
	MIN.	MAX.	MIN.	MAX.
A		330		12.992
B	1.5		0.059	
C	12.8	13.2	0.504	0.520
D	20.2		0.795	
G	24.4	26.4	0.960	1.039
N	100		3.937	
T		30.4		1.197

BASE QTY	BULK QTY
1000	1000

* on sales type

Information furnished is believed to be accurate and reliable. However, STMicroelectronics assumes no responsibility for the consequences of use of such information nor for any infringement of patents or other rights of third parties which may result from its use. No license is granted by implication or otherwise under any patent or patent rights of STMicroelectronics. Specifications mentioned in this publication are subject to change without notice. This publication supersedes and replaces all information previously supplied. STMicroelectronics products are not authorized for use as critical components in life support devices or systems without express written approval of STMicroelectronics.

© The ST logo is a registered trademark of STMicroelectronics

© 2003 STMicroelectronics - Printed in Italy - All Rights Reserved
STMicroelectronics GROUP OF COMPANIES

Australia - Brazil - Canada - China - Finland - France - Germany - Hong Kong - India - Israel - Italy - Japan - Malaysia - Malta - Morocco
Singapore - Spain - Sweden - Switzerland - United Kingdom - United States.

© <http://www.st.com>