

HiPerFET™ Power MOSFET

Single MOSFET Die

Preliminary data sheet

IXFE 24N100
IXFE 23N100

V_{DSS}	I_{D25}	$R_{DS(on)}$
1000 V	22 A	0.39 Ω
1000 V	21 A	0.43 Ω

$t_{rr} \leq 250$ ns

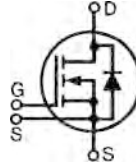

ISOPLUS 227™ (IXFE)



G = Gate
S = Source
D = Drain

Either Source terminal at miniBLOC can be used as Main or Kelvin Source

Symbol Test Conditions		Maximum Ratings	
V_{DSS}	$T_J = 25^\circ\text{C}$ to 150°C	1000	V
V_{DGR}	$T_J = 25^\circ\text{C}$ to 150°C , $R_{GS} = 1\text{M}\Omega$	1000	V
V_{GS}	Continuous	± 20	V
V_{GSM}	Transient	± 30	V
I_{D25}	$T_C = 25^\circ\text{C}$	24N100	22 A
		23N100	21 A
I_{DM}	$T_C = 25^\circ\text{C}$; Note 1	24N100	96 A
		23N100	92 A
I_{AR}	$T_C = 25^\circ\text{C}$	24	A
E_{AR}	$T_C = 25^\circ\text{C}$	60	mJ
E_{AS}	$T_C = 25^\circ\text{C}$	3	J
dv/dt	$I_S \leq I_{DM}$, $di/dt \leq 100$ A/ μs , $V_{DD} \leq V_{DSS}$ $T_J \leq 150^\circ\text{C}$, $R_G = 2 \Omega$	5	V/ns
P_D	$T_C = 25^\circ\text{C}$	500	W
T_J		-55 ... +150	$^\circ\text{C}$
T_{JM}		150	$^\circ\text{C}$
T_{stg}		-55 ... +150	$^\circ\text{C}$
T_L	1.6 mm (0.063 in) from case for 10 s	300	$^\circ\text{C}$
V_{ISOL}	50/60 Hz, RMS $t = 1$ min $I_{ISOL} \leq 1$ mA $t = 1$ s	2500	V~
		3000	V~
M_d	Mounting torque Terminal connection torque	1.5/13 Nm/lb.in.	
		1.5/13 Nm/lb.in.	
Weight		19	g

Features

- Conforms to SOT-227B outline
- Low $R_{DS(on)}$ HDMOS™ process
- Rugged polysilicon gate cell structure
- Unclamped Inductive Switching (UIS) rated
- Low package inductance
- Fast intrinsic Rectifier

Applications

- DC-DC converters
- Battery chargers
- Switched-mode and resonant-mode power supplies
- DC choppers
- Temperature and lighting controls

Advantages

- Low cost
- Easy to mount
- Space savings
- High power density

Symbol	Test Conditions ($T_J = 25^\circ\text{C}$, unless otherwise specified)	Characteristic Values		
		Min.	Typ.	Max.
V_{DSS}	$V_{GS} = 0$ V, $I_D = 3$ mA	1000		V
$V_{GS(th)}$	$V_{DS} = V_{GS}$, $I_D = 8$ mA	3.0		5.0 V
I_{GSS}	$V_{GS} = \pm 20$ V, $V_{DS} = 0$ V			± 200 nA
I_{DSS}	$V_{DS} = V_{DSS}$ $V_{GS} = 0$ V	$T_J = 25^\circ\text{C}$ $T_J = 125^\circ\text{C}$		100 μA 2 mA
$R_{DS(on)}$	$V_{GS} = 10$ V, $I_D = I_T$ Note 2	23N100 24N100		0.43 Ω 0.39 Ω

Symbol	Test Conditions	Characteristic Values		
		Min.	Typ.	Max.
g_{fs}	$V_{DS} = 10\text{ V}; I_D = I_T$, Note 2	15	22	S
C_{iss}	$V_{GS} = 0\text{ V}, V_{DS} = 25\text{ V}, f = 1\text{ MHz}$		7000	pF
C_{oss}			750	pF
C_{rss}			260	pF
$t_{d(on)}$ t_r $t_{d(off)}$ t_f	$V_{GS} = 10\text{ V}, V_{DS} = 0.5 \cdot V_{DSS}, I_D = I_T$ $R_G = 1\ \Omega$ (External),		35	ns
			35	ns
			75	ns
			21	ns
$Q_{g(on)}$ Q_{gs} Q_{gd}	$V_{GS} = 10\text{ V}, V_{DS} = 0.5 \cdot V_{DSS}, I_D = I_T$		250	nC
			55	nC
			135	nC
R_{thJC} R_{thCK}			0.25	K/W
			0.07	K/W

Source-Drain Diode

($T_J = 25^\circ\text{C}$, unless otherwise specified)

Symbol	Test Conditions	Characteristic Values			
		Min.	Typ.	Max.	
I_S	$V_{GS} = 0$	24N100 23N100		24 23	A A
I_{SM}	Repetitive; pulse width limited by T_{JM}	24N100 23N100		96 92	A A
V_{SD}	$I_F = I_S, V_{GS} = 0\text{ V}$, Pulse test, $t \leq 300\ \mu\text{s}$, duty cycle $d \leq 2\%$			1.5	V
t_{rr} Q_{RM} I_{RM}	$I_F = I_S, -di/dt = 100\text{ A}/\mu\text{s}, V_R = 100\text{ V}$		1.0	250	ns μC A
			8		

- Notes:
1. Pulse width limited by T_{JM} .
 2. Pulse test, $t \leq 300\text{ ms}$, duty cycle $d \leq 2\%$.
 3. I_T Test current:
24N100: $I_T = 12\text{ A}$
23N100: $I_T = 11.5\text{ A}$

ISOPLUS-227 B

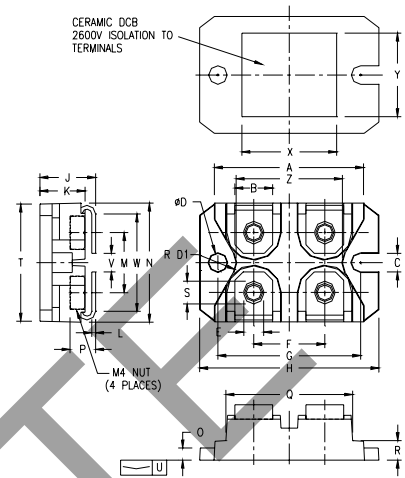

SYM	INCHES		MILLIMETERS	
	MIN	MAX	MIN	MAX
A	1.240	1.270	31.50	32.26
B	.310	.330	7.87	8.38
C	.155	.165	3.94	4.19
D	.155	.165	3.94	4.19
D1	.150	.157	3.81	3.98
E	.160	.168	4.06	4.27
F	.587	.595	14.91	15.11
G	1.186	1.193	30.12	30.30
H	1.489	1.505	37.80	38.23
J	.465	.481	11.81	12.22
K	.370	.380	9.40	9.65
L	.030	.033	0.76	0.84
M	.496	.506	12.60	12.85
N	.990	1.001	25.15	25.42
O	.100	.105	2.54	2.67
P	.195	.235	4.95	5.97
Q	1.045	1.059	26.54	26.90
R	.160	.170	4.06	4.32
S	.186	.191	4.72	4.85
T	.968	.987	24.59	25.07
U	-.001	.002	-0.03	0.05
V	.130	.160	3.30	4.06
W	.780	.830	19.81	21.08
X	.770	.810	19.56	20.57
Y	.680	.720	17.27	18.29
Z	.885	.892	22.48	22.66

Please see IXFN24N100 data sheet for characteristic curves.