

High Voltage MOSFET

N-Channel, Depletion Mode

IXTP 01N100D
IXTU 01N100D
IXTY 01N100D

$V_{DSS} = 1000 \text{ V}$
 $I_{D25} = 100 \text{ mA}$
 $R_{DS(on)} = 110 \text{ } \Omega$

Preliminary Data Sheet

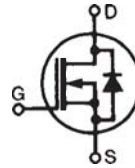

Symbol	Test Conditions	Maximum Ratings		
V_{DSX}	$T_J = 25^\circ\text{C}$ to 150°C	1000	V	
V_{DGX}	$T_J = 25^\circ\text{C}$ to 150°C	1000	V	
V_{GS}	Continuous	± 20	V	
V_{GSM}	Transient	± 30	V	
I_{DSS}	$T_C = 25^\circ\text{C}$; $T_J = 25^\circ\text{C}$ to 150°C	100	mA	
I_{DM}	$T_C = 25^\circ\text{C}$, pulse width limited by T_J	400	mA	
P_D	$T_C = 25^\circ\text{C}$	25	W	
	$T_A = 25^\circ\text{C}$	1.1	W	
T_J		-55 ... +150	$^\circ\text{C}$	
T_{JM}		150	$^\circ\text{C}$	
T_{stg}		-55 ... +150	$^\circ\text{C}$	
T_L	1.6 mm (0.063 in.) from case for 10 s	300	$^\circ\text{C}$	
T_{ISOL}	Plastic case for 10 s (IXTU)	300	$^\circ\text{C}$	
M_d	Mounting torque	TO-220	1.3 / 10	Nm/lb.
Weight		TO-220	4	g
		TO-251	0.8	g
		TO-252	0.8	g

TO-220 (IXTP)

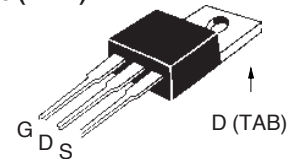

TO-251 (IXTU)

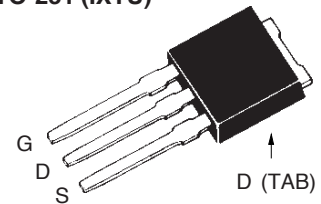

TO-252 (IXTY)

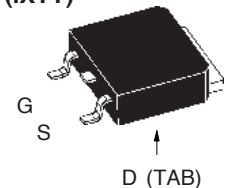

Pins: 1 - Gate 2 - Drain
 3 - Source TAB - Drain

Symbol	Test Conditions ($T_J = 25^\circ\text{C}$, unless otherwise specified)	Characteristic Values		
		min.	typ.	max.
V_{DSX}	$V_{GS} = -10 \text{ V}$, $I_D = 25 \text{ } \mu\text{A}$	1000		V
$V_{GS(off)}$	$V_{DS} = 25 \text{ V}$, $I_D = 25 \text{ } \mu\text{A}$	-2.5		-5 V
I_{GSS}	$V_{GS} = \pm 20 \text{ V}_{DC}$, $V_{DS} = 0$			$\pm 100 \text{ nA}$
$I_{DSX(off)}$	$V_{DS} = V_{DSX}$, $V_{GS} = -10 \text{ V}$ $T_J = 125^\circ\text{C}$			10 μA 250 μA
$R_{DS(on)}$	$V_{GS} = 0 \text{ V}$, $I_D = 50 \text{ mA}$ Note 1		90	110 Ω
$I_{D(on)}$	$V_{GS} = 0 \text{ V}$, $V_{DS} = 25 \text{ V}$ Note 1		100	mA

Features

- Normally ON mode
- Low $R_{DS(on)}$ HDMOS™ process
- Rugged polysilicon gate cell structure
- Fast switching speed

Applications

- Level shifting
- Triggers
- Solid state relays
- Current regulators

Symbol	Test Conditions	Characteristic Values ($T_J = 25^\circ\text{C}$, unless otherwise specified)	Characteristic Values		
			min.	typ.	max.
g_{fs}	$V_{DS} = 50\text{ V}; I_D = 100\text{ mA}$ Note1		100	150	mS
C_{iss}	$V_{GS} = -10\text{ V}, V_{DS} = 25\text{ V}, f = 1\text{ MHz}$			120	pF
C_{oss}				25	pF
C_{rss}				5	pF
$t_{d(on)}$	$V_{DS} = 100\text{ V}, I_D = 50\text{ mA}$ $V_{GS} = 0\text{ V to } -10$ $R_G = 30\Omega$ (External)			8	ns
t_r				6	ns
$t_{d(off)}$				30	ns
t_f				51	ns
R_{thJC}	TO-220			5	K/W
R_{thCS}				0.25	K/W

Source-Drain Diode		Characteristic Values ($T_J = 25^\circ\text{C}$, unless otherwise specified)		
Symbol	Test Conditions	min.	typ.	max.
V_{SD}	$V_{GS} = -10\text{ V}, I_F = 100\text{ mA}$ Note1		1.0	1.5 V
t_{rr}	$I_F = 0.75\text{ A}, -di/dt = 10\text{ A}/\mu\text{s},$ $V_{DS} = 25\text{ V}, V_{GS} = -10\text{ V}$			1.5 μs

Note1: Pulse test, $t \leq 300\ \mu\text{s}$, duty cycle $d \leq 2\%$

TO-252 AA Outline

Dim.	Millimeter		Inches	
	Min.	Max.	Min.	Max.
A	2.19	2.38	0.086	0.094
A1	0.89	1.14	0.035	0.045
A2	0	0.13	0	0.005
b	0.64	0.89	0.025	0.035
b1	0.76	1.14	0.030	0.045
b2	5.21	5.46	0.205	0.215
c	0.46	0.58	0.018	0.023
c1	0.46	0.58	0.018	0.023
D	5.97	6.22	0.235	0.245
D1	4.32	5.21	0.170	0.205
E	6.35	6.73	0.250	0.265
E1	4.32	5.21	0.170	0.205
e	2.28 BSC		0.090 BSC	
e1	4.57 BSC		0.180 BSC	
H	9.40	10.42	0.370	0.410
L	0.51	1.02	0.020	0.040
L1	0.64	1.02	0.025	0.040
L2	0.89	1.27	0.035	0.050
L3	2.54	2.92	0.100	0.115

Pins: 1 - Gate 2 - Drain
3 - Source TAB - Drain

TO-220 AD Outline

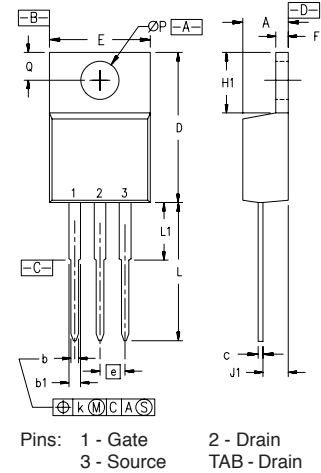

SYM	INCHES		MILLIMETERS	
	MIN	MAX	MIN	MAX
A	.170	.190	4.32	4.83
b	.025	.040	0.64	1.02
b1	.045	.065	1.15	1.65
c	.014	.022	0.35	0.56
D	.580	.630	14.73	16.00
E	.390	.420	9.91	10.66
e	.100 BSC		2.54 BSC	
F	.045	.055	1.14	1.40
H1	.230	.270	5.85	6.85
J1	.090	.110	2.29	2.79
k	0	.015	0	0.38
L	.500	.550	12.70	13.97
L1	.110	.230	2.79	5.84
ØP	.139	.161	3.53	4.08
Q	.100	.125	2.54	3.18

TO-251 AA Outline

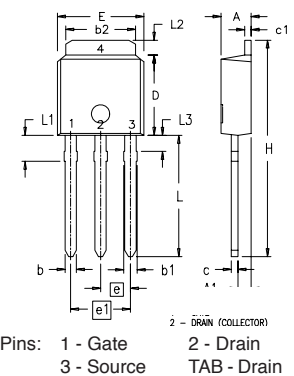

Dim.	Millimeter		Inches	
	Min.	Max.	Min.	Max.
A	2.19	2.38	.086	.094
A1	0.89	1.14	0.035	.045
b	0.64	0.89	.025	.035
b1	0.76	1.14	0.030	0.045
b2	5.21	5.46	.205	.215
c	0.46	0.58	.018	.023
c1	0.46	0.58	.018	.023
D	5.97	6.22	.235	.245
E	6.35	6.73	.250	.265
e	2.28	BSC	.090	BSC
e1	4.57	BSC	.180	BSC
H	17.02	17.78	.670	.700
L	8.89	9.65	.350	.380
L1	1.91	2.28	.075	.090
L2	0.89	1.27	.035	.050
L3	1.15	1.52	.045	.060

IXYS reserves the right to change limits, test conditions, and dimensions.

IXYS MOSFETs and IGBTs are covered by one or more of the following U.S. patents:	4,835,592	4,931,844	5,049,961	5,237,481	6,162,665	6,404,065 B1	6,683,344	6,727,585
	4,850,072	5,017,508	5,063,307	5,381,025	6,259,123 B1	6,534,343	6,710,405 B2	6,759,692
	4,881,106	5,034,796	5,187,117	5,486,715	6,306,728 B1	6,583,505	6,710,463	