

Automotive-grade N-channel 40 V, 1.6 mΩ typ., 160 A STripFET™ F3 Power MOSFET in a D²PAK package

Datasheet - production data

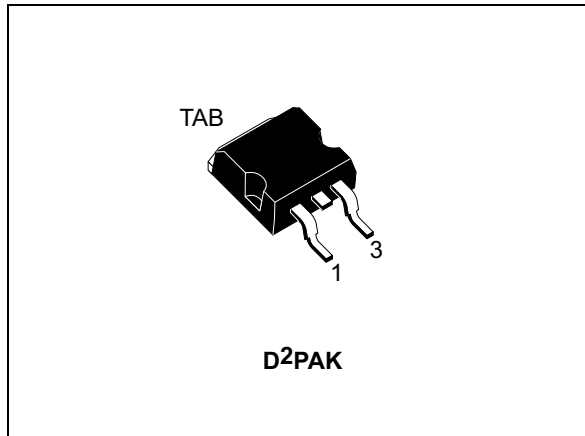
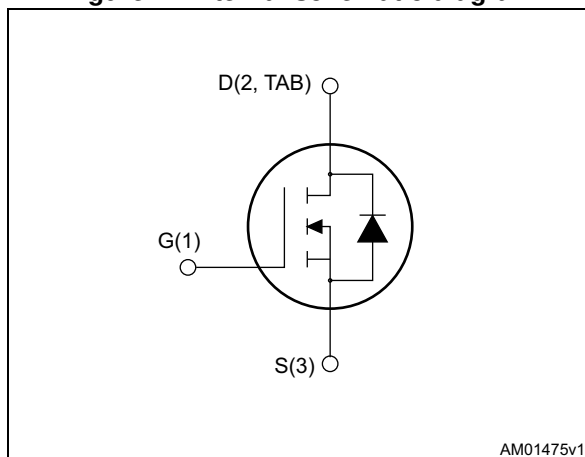

Figure 1. Internal schematic diagram



Features

Type	V _{DS}	R _{DS(on) max}	I _D	P _{TOT}
STB270N4F3	40 V	2.0 mΩ	160 A	330 W

- Designed for automotive applications and AEC-Q101 qualified
- 100% avalanche tested
- Standard threshold drive

Applications

- Switching application

Description

This device is an N-channel Power MOSFET developed using STripFET™ F3 technology. It is designed to minimize on-resistance and gate charge to provide superior switching performance.

Table 1. Device summary

Order codes	Marking	Package	Packaging
STB270N4F3	270N4F3	D ² PAK	Tape and reel

Contents

1	Electrical ratings	3
2	Electrical characteristics	4
	2.1 Electrical characteristics (curves)	6
3	Test circuit	8
4	Package information	9
	4.1 D ² PAK package information	9
5	Packing information	12
6	Revision history	14



1 Electrical ratings

Table 2. Absolute maximum ratings

Symbol	Parameter	Value	Unit
V_{DS}	Drain-source voltage	40	V
V_{GS}	Gate-source voltage	± 20	V
$I_D^{(1)}$	Drain current (continuous) at $T_C = 25\text{ }^\circ\text{C}$	160	A
$I_D^{(1)}$	Drain current (continuous) at $T_C=100\text{ }^\circ\text{C}$	160	A
$I_{DM}^{(2)}$	Drain current (pulsed)	640	A
P_{TOT}	Total dissipation at $T_C = 25\text{ }^\circ\text{C}$	330	W
$dv/dt^{(3)}$	Peak diode recovery voltage slope	3.5	V/ns
$E_{AS}^{(4)}$	Single pulse avalanche energy	1	J
T_J T_{stg}	Operating junction temperature Storage temperature	-55 to 175	$^\circ\text{C}$

1. Current limited by package
2. Pulse width limited by safe operating area
3. $I_{SD} \leq 120\text{ A}$, $di/dt \leq 200\text{ A}/\mu\text{s}$, $V_{DD} \leq V_{(BR)DSS}$, $T_j \leq T_{JMAX}$
4. Starting $T_j=25\text{ }^\circ\text{C}$, $I_D = 80\text{ A}$, $V_{DD} = 32\text{ V}$

Table 3. Thermal data

Symbol	Parameter	Value	Unit
$R_{thj-case}$	Thermal resistance junction-case max	0.45	$^\circ\text{C}/\text{W}$
$R_{thj-pcb}^{(1)}$	Thermal resistance junction-pcb max	35	$^\circ\text{C}/\text{W}$

1. When mounted on 1inch² FR-4 board, 2 oz Cu.

2 Electrical characteristics

($T_{CASE}=25\text{ °C}$ unless otherwise specified)

Table 4. On/off states

Symbol	Parameter	Test conditions	Min.	Typ.	Max.	Unit
$V_{(BR)DSS}$	Drain-source breakdown voltage	$I_D = 250\ \mu\text{A}$, $V_{GS} = 0$	40			V
I_{DSS}	Zero gate voltage drain current ($V_{GS} = 0$)	$V_{DS} = 40\ \text{V}$ $V_{DS} = 40\ \text{V}$, $T_j = 125\text{ °C}$			10 100	μA μA
I_{GSS}	Gate body leakage current ($V_{DS} = 0$)	$V_{GS} = \pm 20\ \text{V}$			± 200	nA
$V_{GS(th)}$	Gate threshold voltage	$V_{DS} = V_{GS}$, $I_D = 250\ \mu\text{A}$	2		4	V
$R_{DS(on)}$	Static drain-source on resistance	$V_{GS} = 10\ \text{V}$, $I_D = 80\ \text{A}$		1.6	2.0	m Ω

Table 5. Dynamic

Symbol	Parameter	Test conditions	Min.	Typ.	Max.	Unit
$g_{fs}^{(1)}$	Forward transconductance	$V_{DS} = 15\ \text{V}$, $I_D = 80\ \text{A}$	-	200		S
C_{iss}	Input capacitance	$V_{DS} = 25\ \text{V}$, $f = 1\ \text{MHz}$, $V_{GS} = 0$	-	7400		pf
C_{oss}	Output capacitance		-	1800		pF
C_{rss}	Reverse transfer capacitance		-	47		pF
Q_g	Total gate charge	$V_{DD} = 20\ \text{V}$, $I_D = 160\ \text{A}$	-	110	150	nC
Q_{gs}	Gate-source charge	$V_{GS} = 10\ \text{V}$	-	27		nC
Q_{gd}	Gate-drain charge	(see Figure 14)	-	25		nC

1. Pulsed: pulse duration=300 μs , duty cycle 1.5%

Table 6. Switching times

Symbol	Parameter	Test conditions	Min.	Typ.	Max.	Unit
$t_{d(on)}$	Turn-on delay time	$V_{DD} = 20\ \text{V}$, $I_D = 80\ \text{A}$, $R_G = 4.7\ \Omega$, $V_{GS} = 10\ \text{V}$ (see Figure 16)	-	22	-	ns
t_r	Rise time		-	180	-	ns
$t_{d(off)}$	Turn-off delay time		-	110	-	ns
t_f	Fall time		-	45	-	ns

Table 7. Source drain diode

Symbol	Parameter	Test conditions	Min	Typ.	Max	Unit
I_{SD}	Source-drain current		-		160	A
$I_{SDM}^{(1)}$	Source-drain current (pulsed)		-		640	A
$V_{SD}^{(2)}$	Forward on voltage	$I_{SD}=80\text{ A}$, $V_{GS}=0$	-		1.5	V
t_{rr}	Reverse recovery time	$I_{SD}=160\text{ A}$, $di/dt = 100\text{ A}/\mu\text{s}$, $V_{DD}=32\text{ V}$, $T_j=150\text{ }^\circ\text{C}$ (see Figure 15)	-	70		ns
Q_{rr}	Reverse recovery charge		-	225		nC
I_{RRM}	Reverse recovery current		-	3.2		A

1. Pulse width limited by safe operating area
2. Pulsed: pulse duration=300 μs , duty cycle 1.5%

2.1 Electrical characteristics (curves)

Figure 2. Safe operating area

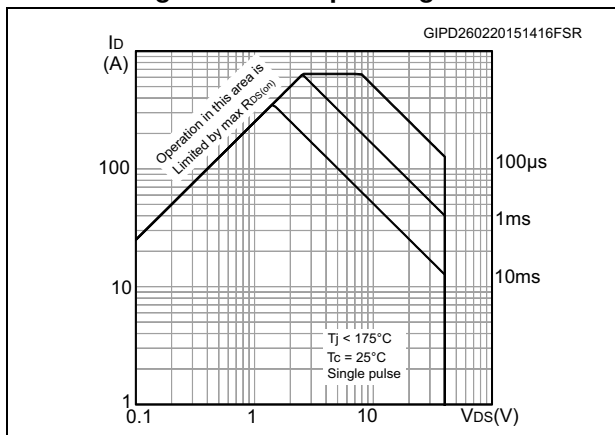

Figure 3. Thermal impedance

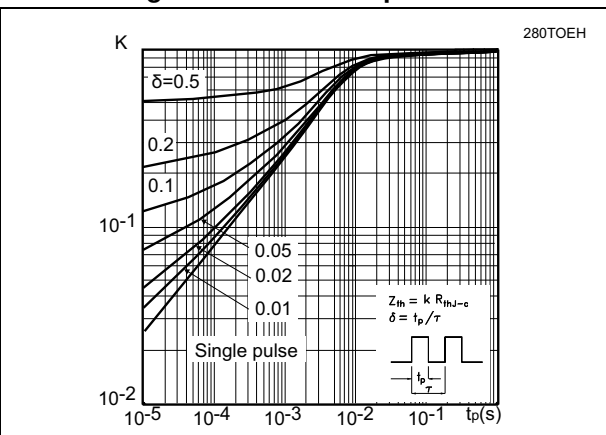

Figure 4. Output characteristics

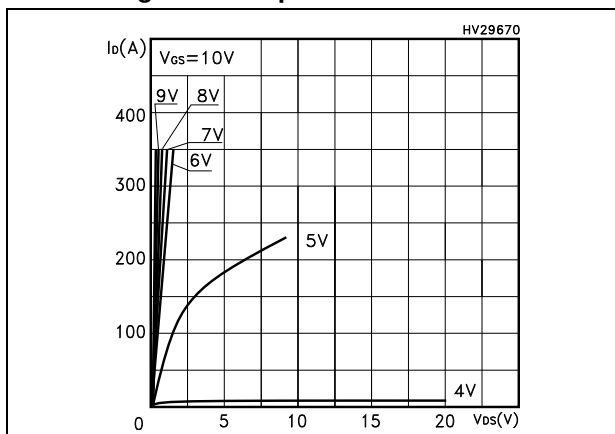

Figure 5. Transfer characteristics

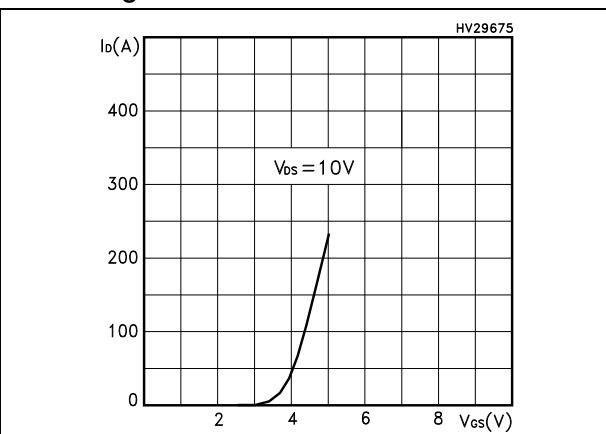

Figure 6. Static drain-source on-resistance

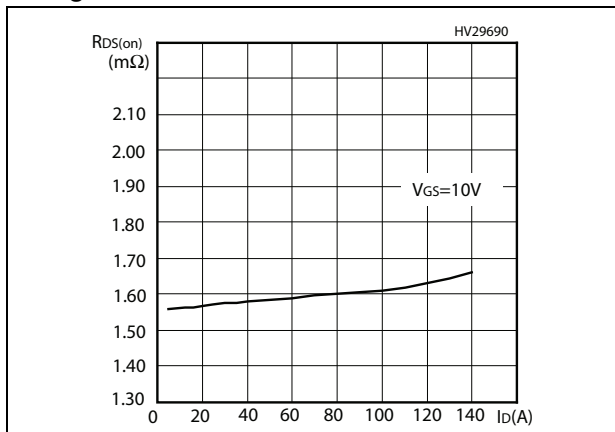

Figure 7. Normalized $B_{V_{DS}}$ vs temperature

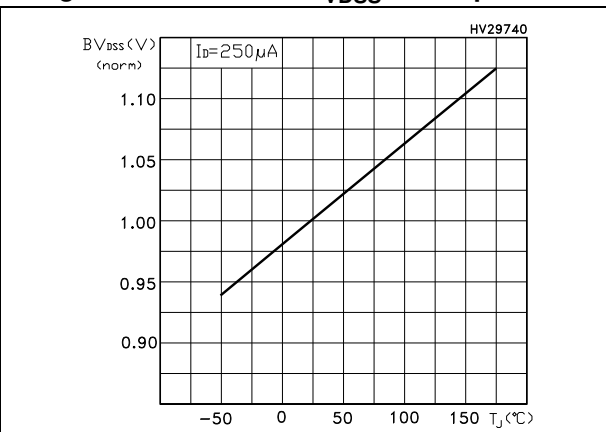

Figure 8. Gate charge vs gate-source voltage

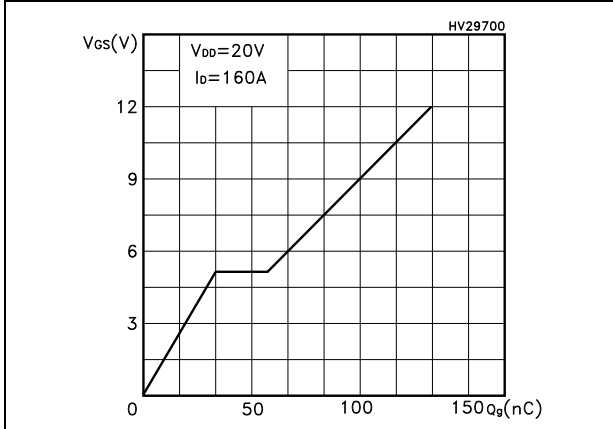

Figure 9. Capacitance variations

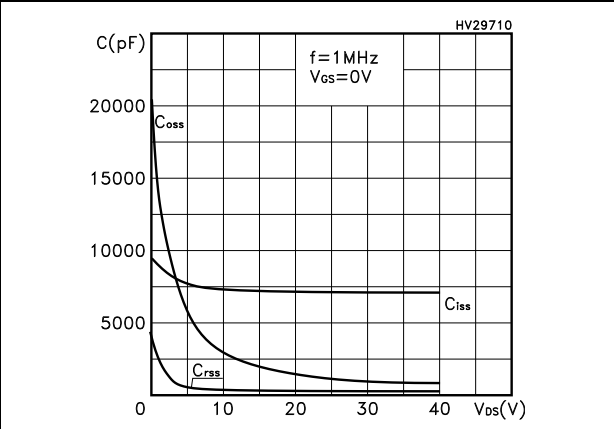

Figure 10. Normalized gate threshold voltage vs temperature

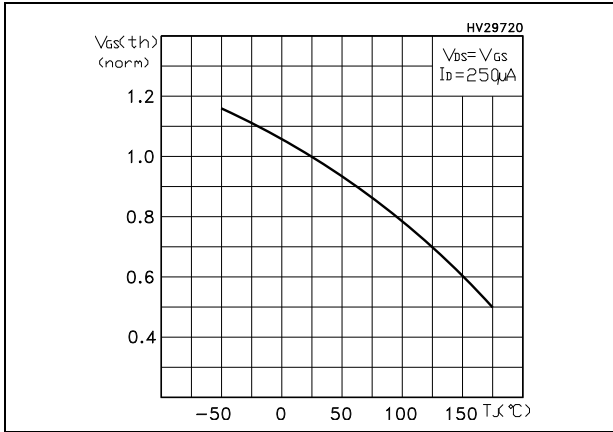

Figure 11. Normalized on resistance vs temperature

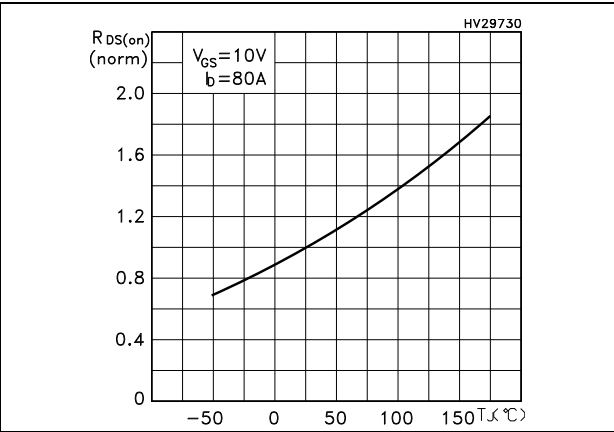
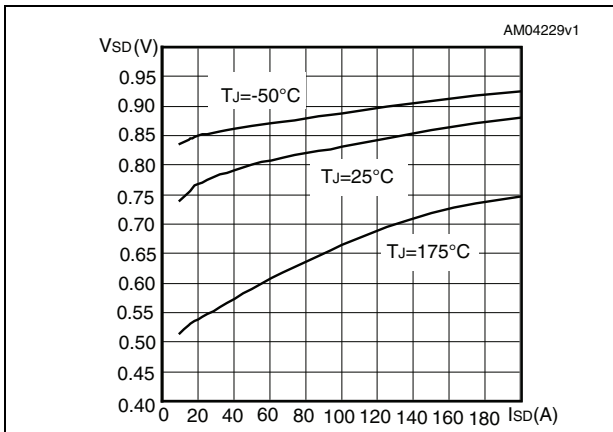

Figure 12. Source-drain diode forward characteristics



3 Test circuit

Figure 13. Switching times test circuit for resistive load

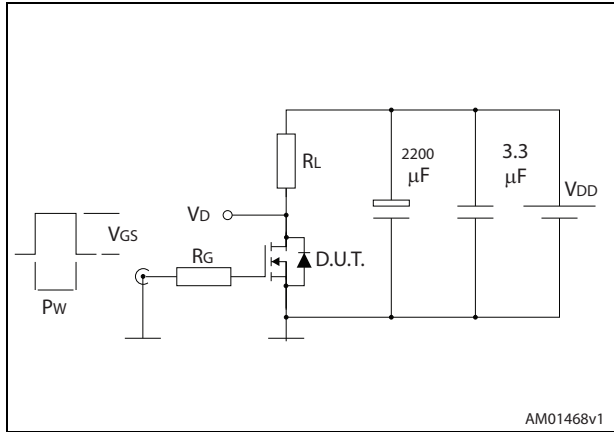

Figure 14. Gate charge test circuit

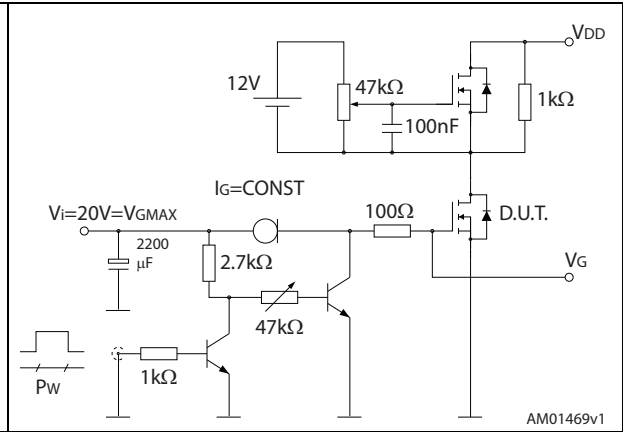

Figure 15. Test circuit for inductive load switching and diode recovery times

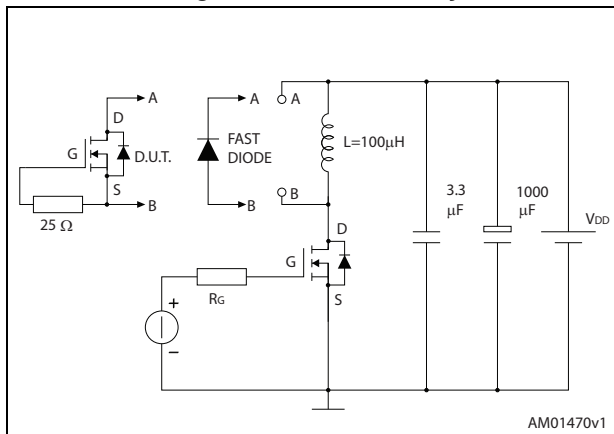

Figure 16. Unclamped inductive load test circuit

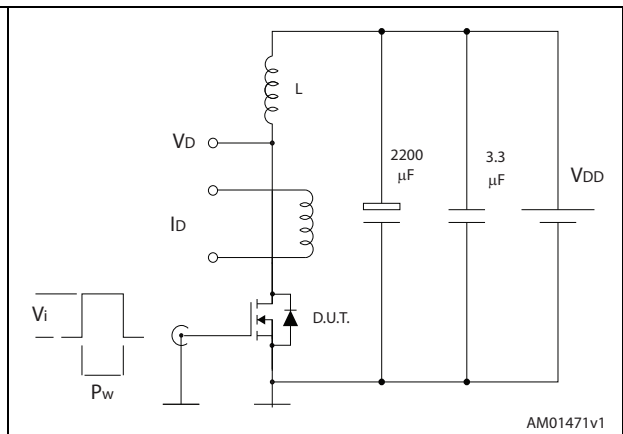

Figure 17. Unclamped inductive waveform

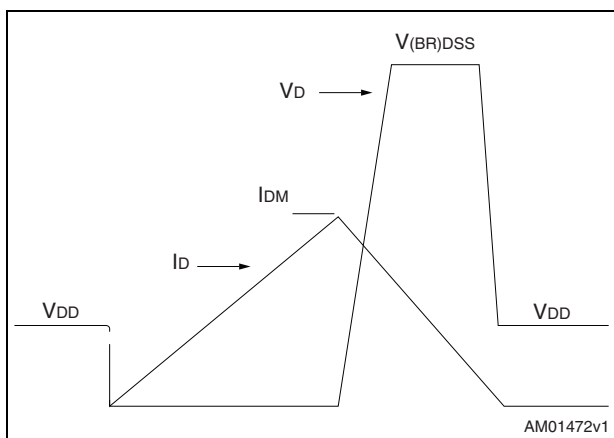
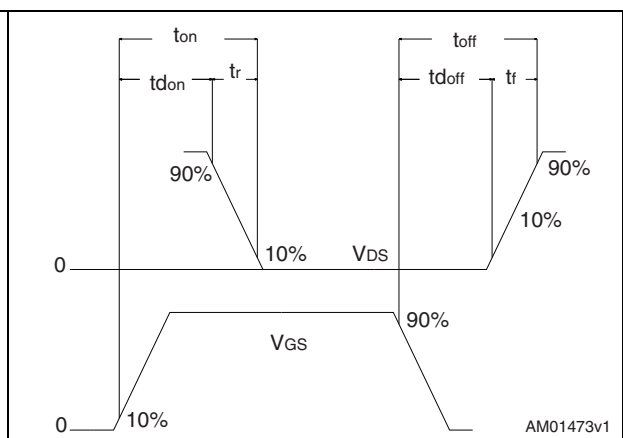

Figure 18. Switching time waveform



4 Package information

In order to meet environmental requirements, ST offers these devices in different grades of ECOPACK® packages, depending on their level of environmental compliance. ECOPACK® specifications, grade definitions and product status are available at: www.st.com. ECOPACK is an ST trademark.

4.1 D²PAK package information

Figure 19. D²PAK (TO-263) outline

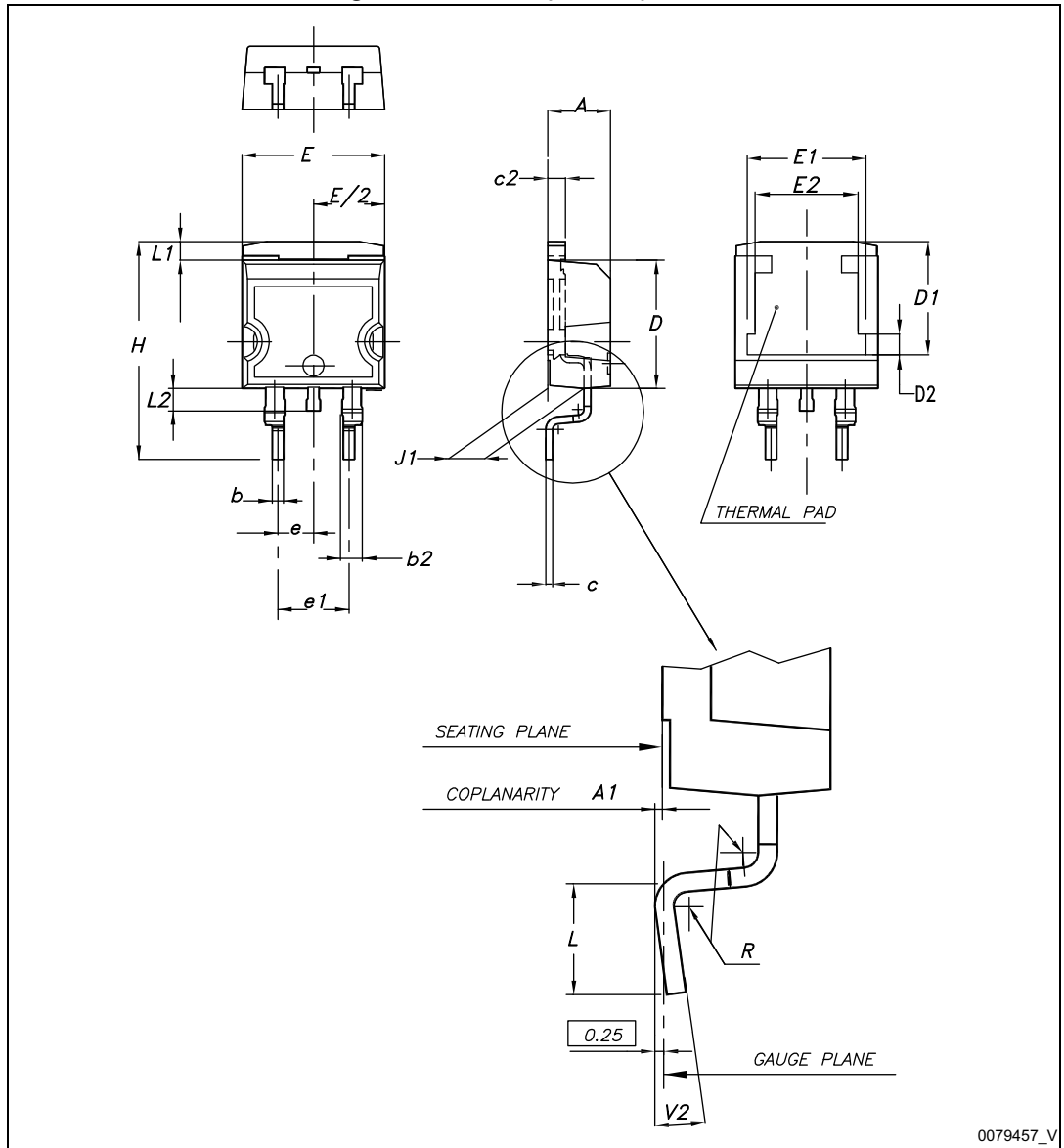
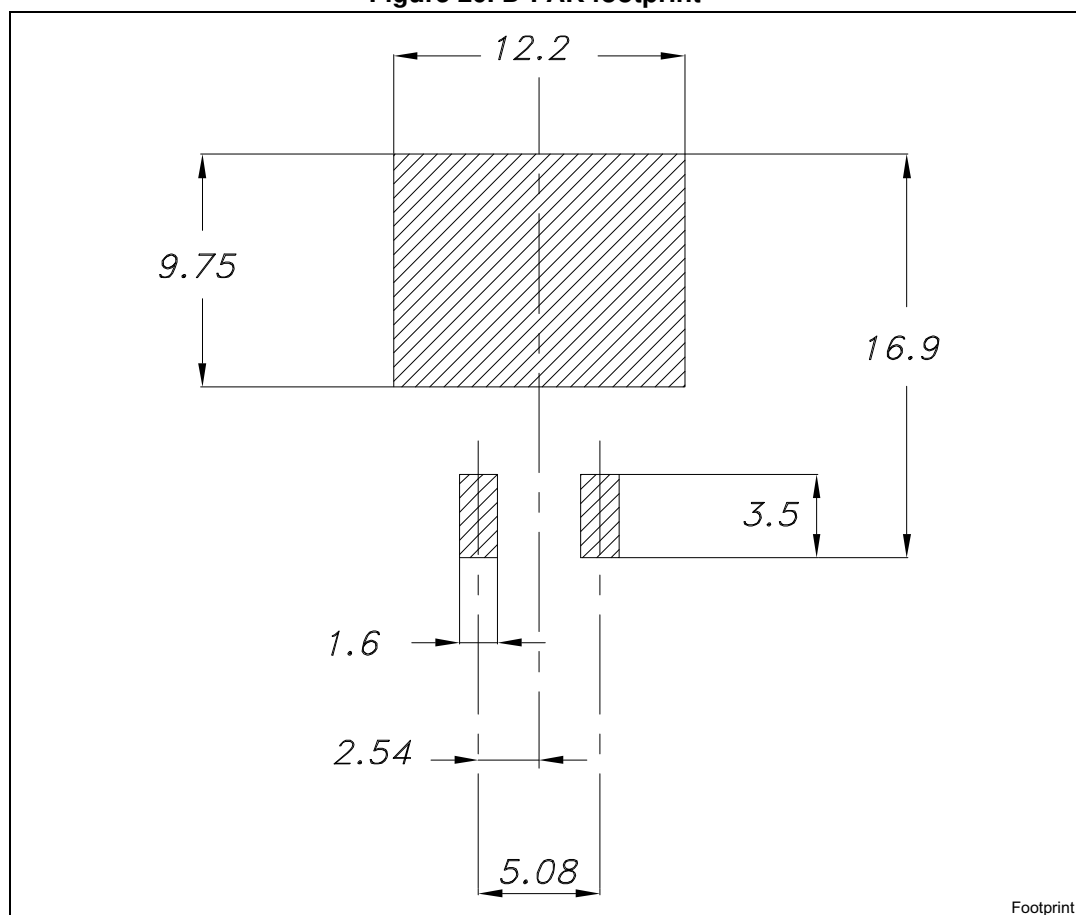

Table 8. D²PAK (TO-263) mechanical data

Dim.	mm		
	Min.	Typ.	Max.
A	4.40		4.60
A1	0.03		0.23
b	0.70		0.93
b2	1.14		1.70
c	0.45		0.60
c2	1.23		1.36
D	8.95		9.35
D1	7.50	7.75	8.00
D2	1.10	1.30	1.50
E	10		10.40
E1	8.50	8.70	8.90
E2	6.85	7.05	7.25
e		2.54	
e1	4.88		5.28
H	15		15.85
J1	2.49		2.69
L	2.29		2.79
L1	1.27		1.40
L2	1.30		1.75
R		0.4	
V2	0°		8°

Figure 20. D²PAK footprint^(a)

Footprint

a. All dimension are in millimeters

5 Packing information

Figure 21. Tape

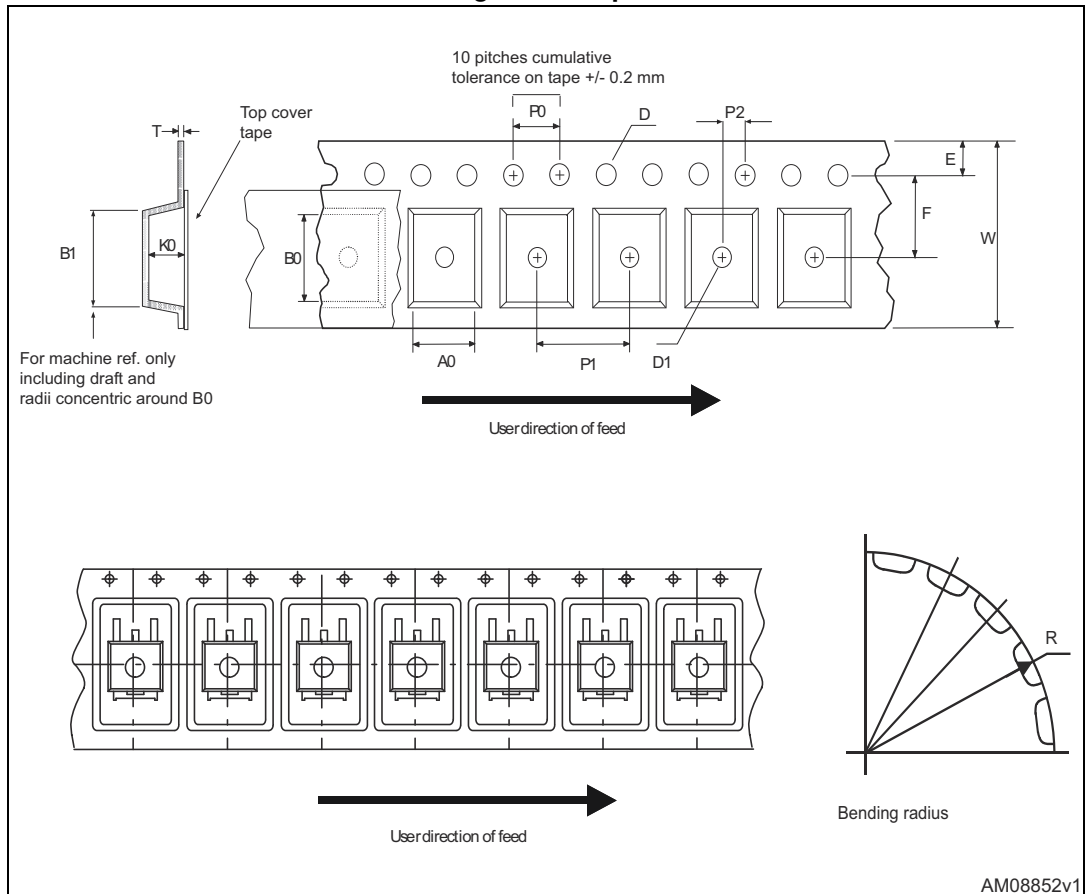

Figure 22. Reel

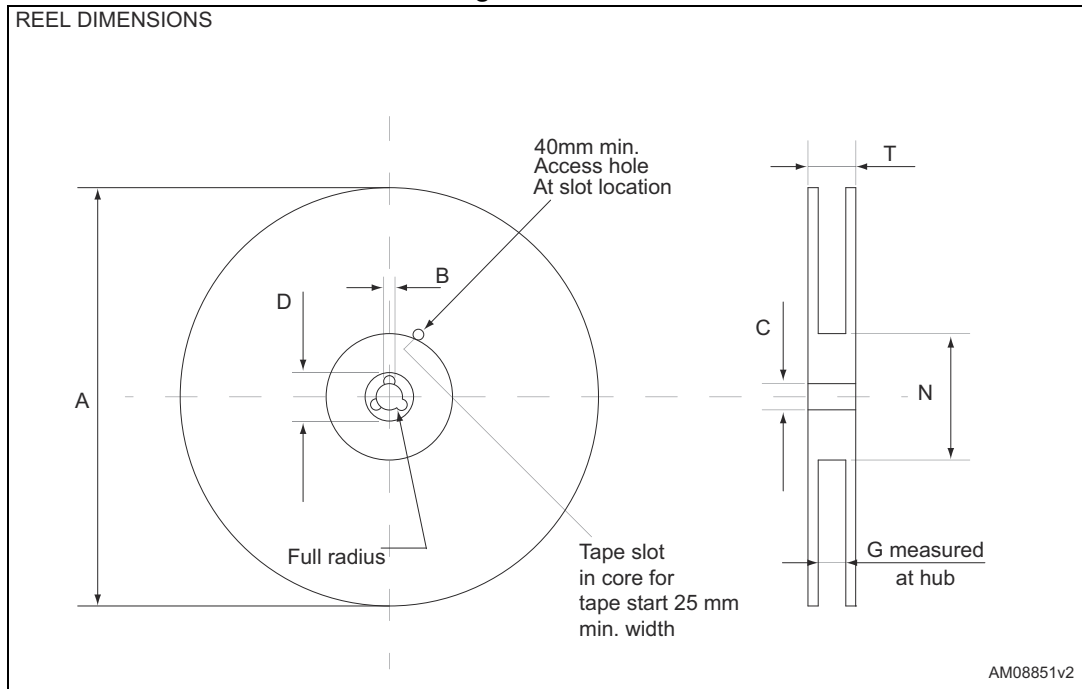

Table 9. D²PAK (TO-263) tape and reel mechanical data

Tape			Reel		
Dim.	mm		Dim.	mm	
	Min.	Max.		Min.	Max.
A0	10.5	10.7	A		330
B0	15.7	15.9	B	1.5	
D	1.5	1.6	C	12.8	13.2
D1	1.59	1.61	D	20.2	
E	1.65	1.85	G	24.4	26.4
F	11.4	11.6	N	100	
K0	4.8	5.0	T		30.4
P0	3.9	4.1			
P1	11.9	12.1	Base qty		1000
P2	1.9	2.1	Bulk qty		1000
R	50				
T	0.25	0.35			
W	23.7	24.3			

6 Revision history

Table 10. Revision history

Date	Revision	Changes
07-Feb-2007	1	Initial release.
02-Apr-2008	2	Some value changes on Table 2
06-May-2009	3	Changed: Description and Figure 12: Source-drain diode forward characteristics
14-Jul-2009	4	Removed package and mechanical data: TO-220
26-Feb-2015	5	The part number STI270N4F3 has been moved to a separate document. Updated title, features and description cover page. Updated Table 2: Absolute maximum ratings , Table 3: Thermal data . Updated Section 4: Package information and Section 5: Packing information . Minor text changes.

IMPORTANT NOTICE – PLEASE READ CAREFULLY

STMicroelectronics NV and its subsidiaries ("ST") reserve the right to make changes, corrections, enhancements, modifications, and improvements to ST products and/or to this document at any time without notice. Purchasers should obtain the latest relevant information on ST products before placing orders. ST products are sold pursuant to ST's terms and conditions of sale in place at the time of order acknowledgement.

Purchasers are solely responsible for the choice, selection, and use of ST products and ST assumes no liability for application assistance or the design of Purchasers' products.

No license, express or implied, to any intellectual property right is granted by ST herein.

Resale of ST products with provisions different from the information set forth herein shall void any warranty granted by ST for such product.

ST and the ST logo are trademarks of ST. All other product or service names are the property of their respective owners.

Information in this document supersedes and replaces information previously supplied in any prior versions of this document.

© 2015 STMicroelectronics – All rights reserved