

N-channel 55 V, 0.0065  $\Omega$  typ., 78 A STripFET™ II  
Power MOSFETs in D<sup>2</sup>PAK and TO-220 packages

Datasheet — production data

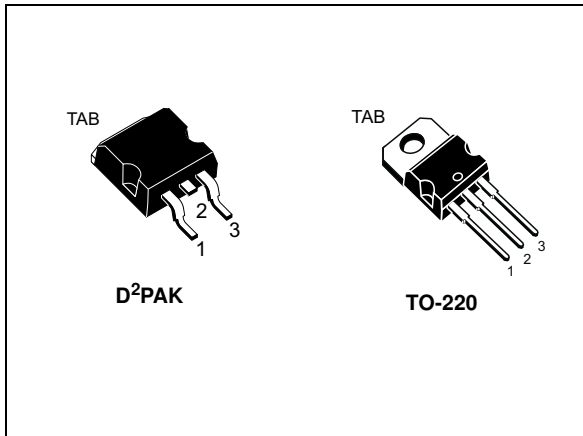
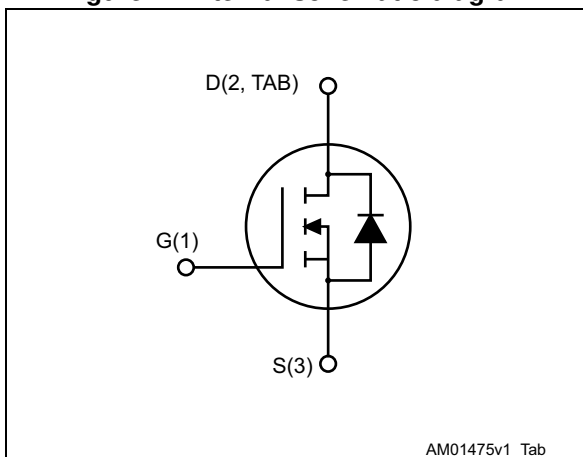

Figure 1. Internal schematic diagram



## Features

Order code	V <sub>DSS</sub>	R <sub>DS(on)</sub> max	I <sub>D</sub>
STB78NF55-08	55 V	0.008 $\Omega$	80 A
STP78NF55-08			

- 100% avalanche tested
- Low input capacitance and gate charge
- Low gate input resistance

## Applications

- Switching applications

## Description

These Power MOSFETs have been developed using STMicroelectronics' unique STripFET process, which is specifically designed to minimize input capacitance and gate charge. This renders the devices suitable for use as primary switch in advanced high-efficiency isolated DC-DC converters for telecom and computer applications, and applications with low gate charge driving requirements.

Table 1. Device summary

Order code	Marking	Packages	Packing
STB78NF55-08	78NF55-08	D <sup>2</sup> PAK	Tape and reel
STP78NF55-08	78NF55-08	TO-220	Tube

# Contents

<b>1</b>	<b>Electrical ratings</b> .....	<b>3</b>
<b>2</b>	<b>Electrical characteristics</b> .....	<b>4</b>
2.1	Electrical characteristics (curves) .....	6
<b>3</b>	<b>Test circuits</b> .....	<b>8</b>
<b>4</b>	<b>Package information</b> .....	<b>9</b>
4.1	D <sup>2</sup> PAK package information .....	9
4.2	TO-220 type A package information .....	12
4.3	TO-220 type B package information .....	14
<b>5</b>	<b>Packing information</b> .....	<b>16</b>
<b>6</b>	<b>Revision history</b> .....	<b>18</b>

# 1 Electrical ratings

**Table 2. Absolute maximum ratings**

Symbol	Parameter	Value	Unit
$V_{DS}$	Drain-source voltage	55	V
$V_{GS}$	Gate-source voltage	$\pm 20$	V
$I_D^{(1)}$	Drain current (continuous) at $T_C = 25\text{ }^\circ\text{C}$	80	A
$I_D^{(1)}$	Drain current (continuous) at $T_C = 100\text{ }^\circ\text{C}$	80	A
$I_{DM}^{(2)}$	Drain current (pulsed)	320	A
$P_{TOT}$	Total dissipation at $T_C = 25\text{ }^\circ\text{C}$	300	W
$T_{stg}$	Operating junction temperature range	- 55 to 175	$^\circ\text{C}$
$T_j$	Storage temperature range		

1. Current limited package
2. Pulse width limited by safe operating area

**Table 3. Thermal data**

Symbol	Parameter	Value		Unit
		D <sup>2</sup> PAK	TO-220	
$R_{thj-case}$	Thermal resistance junction-case	0.5		$^\circ\text{C}/\text{W}$
$R_{thj-pcb}$	Thermal resistance junction-pcb	35 <sup>(1)</sup>		$^\circ\text{C}/\text{W}$
$R_{thj-amb}$	Thermal resistance junction-ambient		62.5	$^\circ\text{C}/\text{W}$

1. When mounted on 1 inch<sup>2</sup> FR-4 board, 2 oz Cu

**Table 4. Avalanche characteristics**

Symbol	Parameter	Value	Unit
$I_{AR}$	Avalanche current, repetitive or not-repetitive (pulse width limited by $T_j$ max)	40	A
$E_{AS}$	Single pulse avalanche energy (starting $T_j=25\text{ }^\circ\text{C}$ , $I_D=I_{AS}$ , $V_{DD}=30\text{ V}$ )	1000	mJ

## 2 Electrical characteristics

( $T_{CASE} = 25\text{ °C}$  unless otherwise specified)

**Table 5. On/off states**

Symbol	Parameter	Test conditions	Min.	Typ.	Max.	Unit
$V_{(BR)DSS}$	Drain-source breakdown voltage	$V_{GS} = 0\text{ V}$ , $I_D = 250\text{ }\mu\text{A}$	55			V
$I_{DSS}$	Zero gate voltage drain current	$V_{GS} = 0\text{ V}$ , $V_{DS} = 55\text{ V}$			1	$\mu\text{A}$
		$V_{GS} = 0\text{ V}$ , $V_{DS} = 55\text{ V}$ , @125 °C <sup>(1)</sup>			10	$\mu\text{A}$
$I_{GSS}$	Gate-body leakage current	$V_{DS} = 0\text{ V}$ $V_{GS} = \pm 20\text{ V}$			$\pm 100$	nA
$V_{GS(th)}$	Gate threshold voltage	$V_{DS} = V_{GS}$ , $I_D = 250\text{ }\mu\text{A}$	2	3	4	V
$R_{DS(on)}$	Static drain-source on-resistance	$V_{GS} = 10\text{ V}$ , $I_D = 40\text{ A}$		0.0065	0.008	$\Omega$

1. Defined by design, not subject to production test

**Table 6. Dynamic**

Symbol	Parameter	Test conditions	Min.	Typ.	Max.	Unit
$g_{fs}^{(1)}$	Forward transconductance	$V_{DS} = 15\text{ V}$ , $I_D = 18\text{ A}$	-	40	-	S
$C_{iss}$	Input capacitance	$V_{GS} = 0\text{ V}$ , $V_{DS} = 25\text{ V}$ , $f = 1\text{ MHz}$		3740		pF
$C_{oss}$	Output capacitance		-	830	-	pF
$C_{riss}$	Reverse transfer capacitance		-	265	-	pF
$Q_g$	Total gate charge	$V_{DD} = 27\text{ V}$ , $I_D = 80\text{ A}$ ,	-	112	155	nC
$Q_{gs}$	Gate-source charge	$V_{GS} = 10\text{ V}$ ,	-	20	-	nC
$Q_{gd}$	Gate-drain charge	( <i>Figure 14: Gate charge test circuit</i> )	-	40	-	nC

1. Pulsed: pulse duration=300  $\mu\text{s}$ , duty cycle 1.5%

**Table 7. Switching times**

Symbol	Parameter	Test conditions	Min.	Typ.	Max.	Unit
$t_{d(on)}$	Turn-on delay time	$V_{DD} = 27\text{ V}$ , $I_D = 40\text{ A}$ $R_G = 4.7\text{ }\Omega$ , $V_{GS} = 10\text{ V}$ ( <i>Figure 13: Switching times test circuit for resistive load and Figure 18: Switching time waveform.</i> )	-	20	-	ns
$t_r$	Rise time		-	110	-	ns
$t_{d(off)}$	Turn-off delay time		-	75	-	ns
$t_f$	Fall time		-	35	-	ns

Table 8. Source drain diode

Symbol	Parameter	Test conditions	Min	Typ.	Max.	Unit
$I_{SD}$	Source-drain current		-		80	A
$I_{SDM}^{(1)}$	Source-drain current (pulsed)		-		320	A
$V_{SD}$	Forward on voltage	$I_{SD} = 80 \text{ A}$ , $V_{GS} = 0 \text{ V}$	-		1.5	V
$t_{rr}^{(2)}$	Reverse recovery time	$I_{SD} = 80 \text{ A}$ , $V_{DD} = 25 \text{ V}$ , $di/dt = 100 \text{ A}/\mu\text{s}$ $T_j = 150 \text{ }^\circ\text{C}$ ( <i>Figure 15: Test circuit for inductive load switching and diode recovery times</i> )	-	80		ns
$Q_{rr}$	Reverse recovery charge		-	230		nC
$I_{RRM}$	Reverse recovery current		-	5.7		A

1. Pulse width limited by safe operating area
2. Pulsed: pulse duration = 300  $\mu\text{s}$ , duty cycle 1.5%

## 2.1 Electrical characteristics (curves)

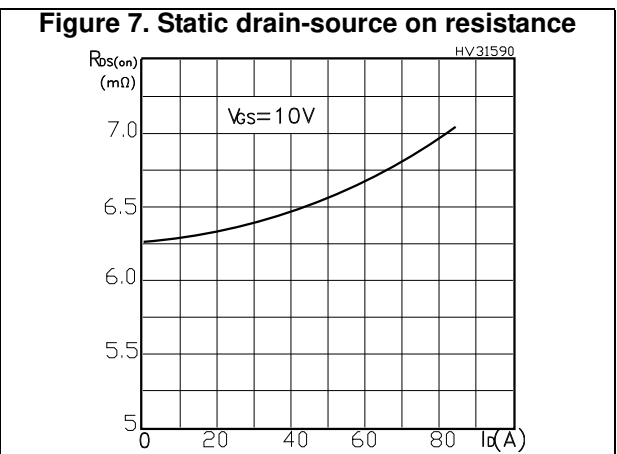
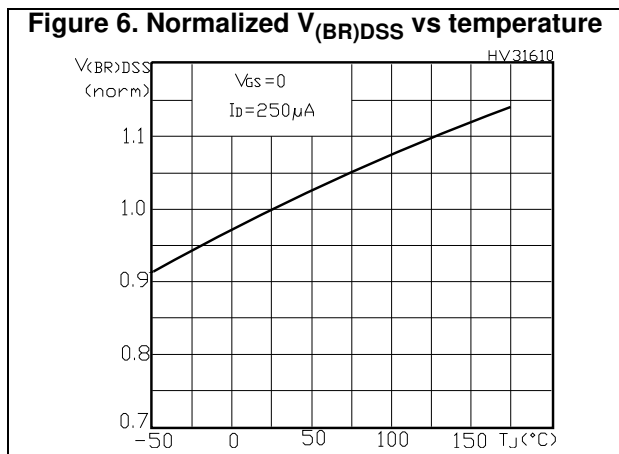
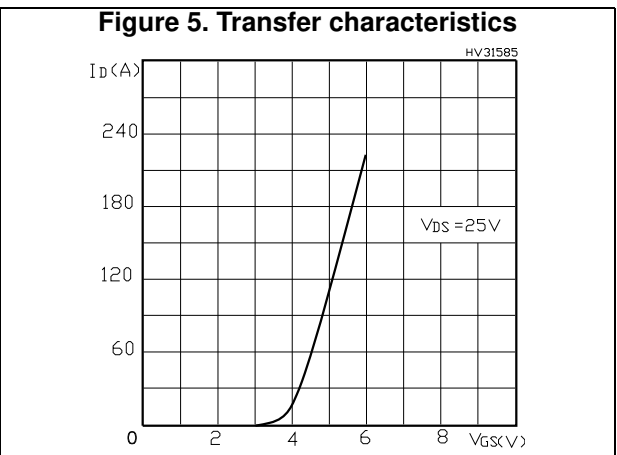
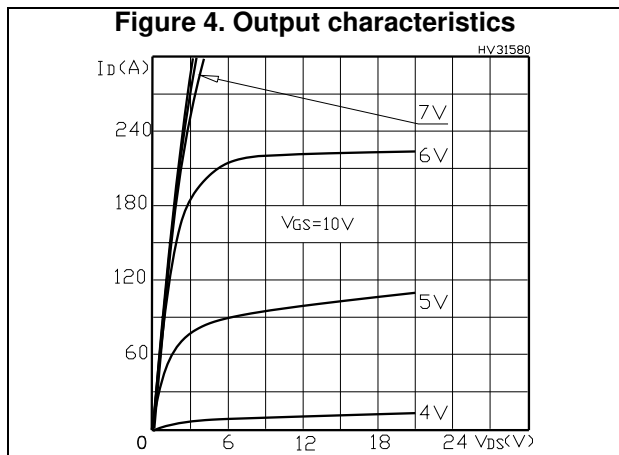
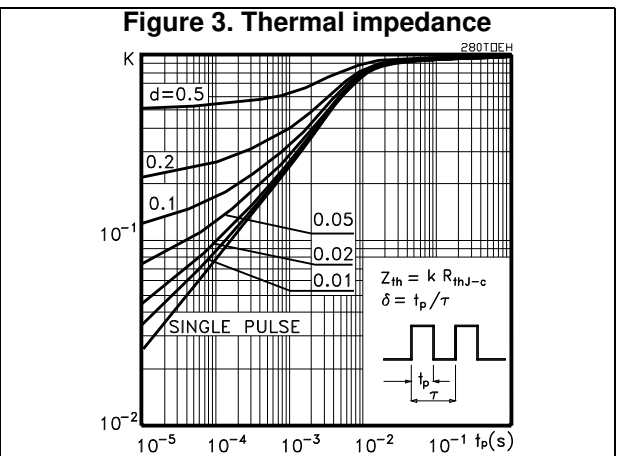
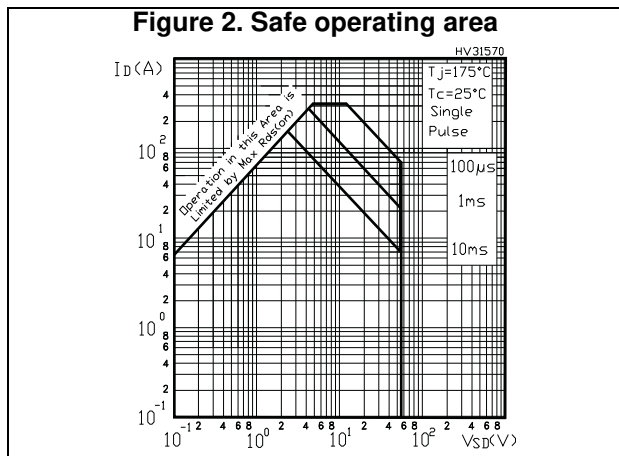

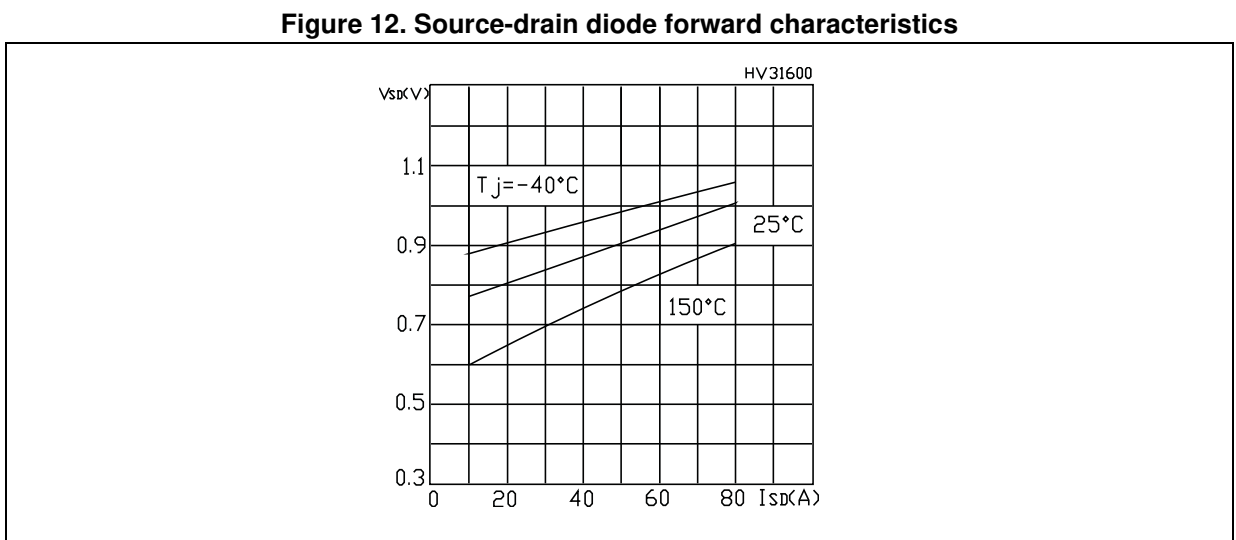
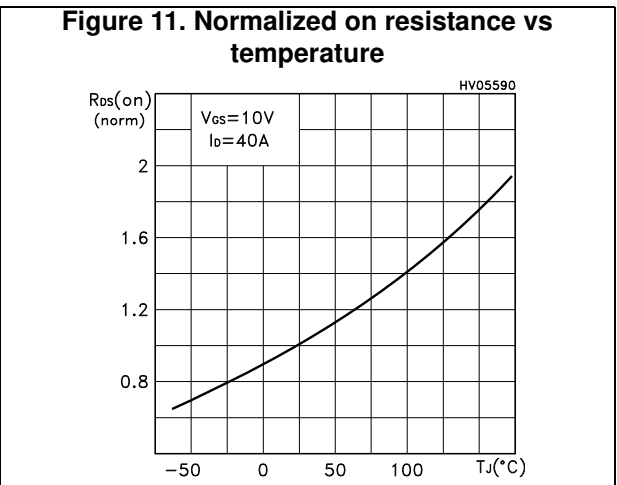
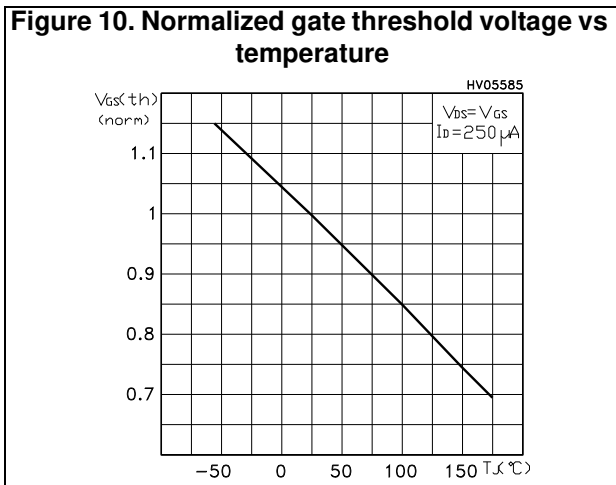
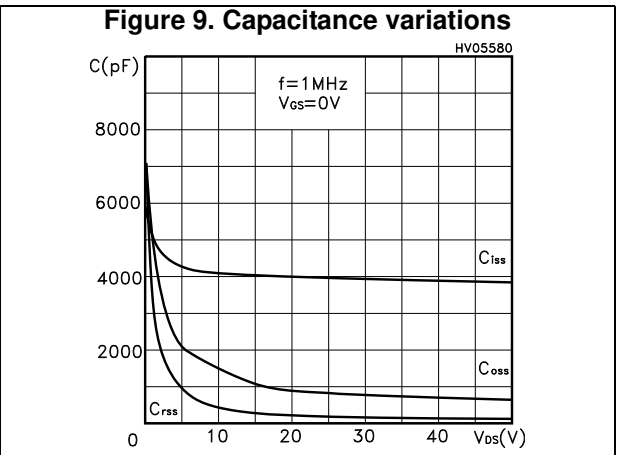
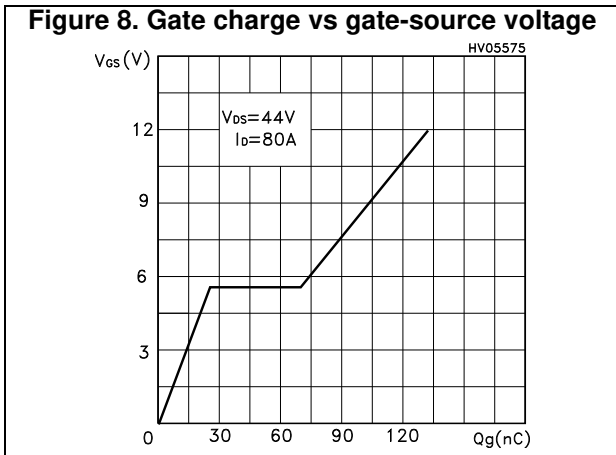

### 3 Test circuits

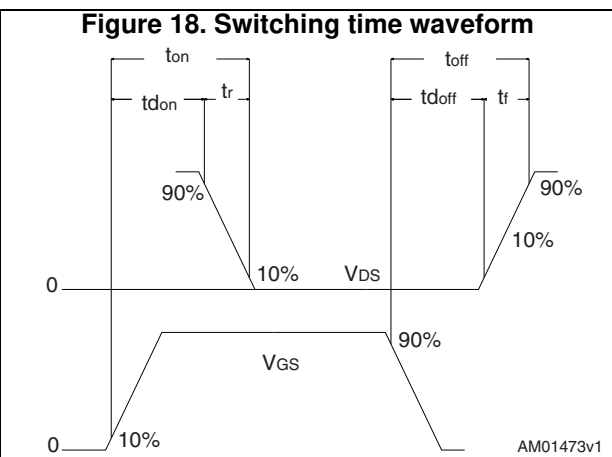
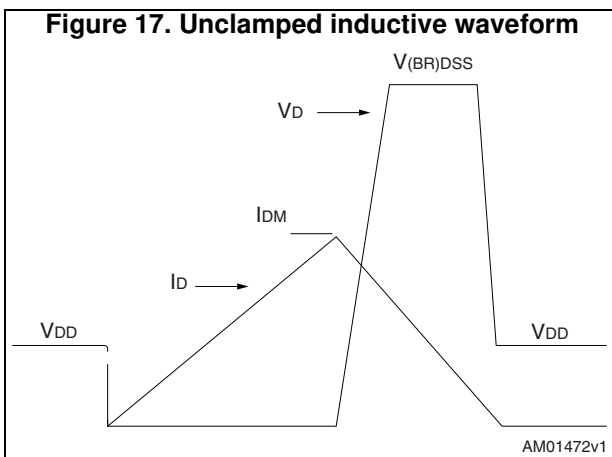
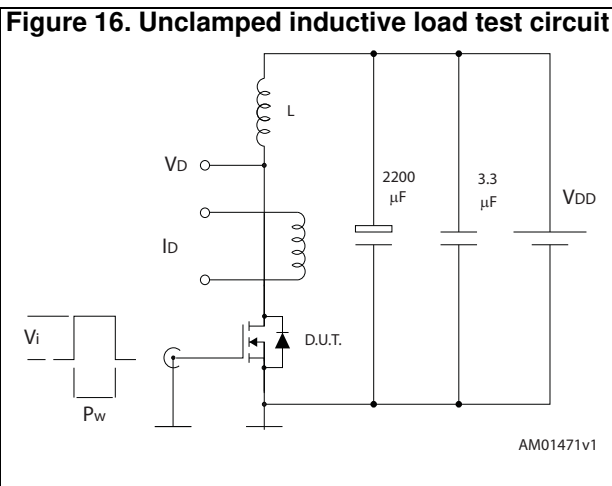
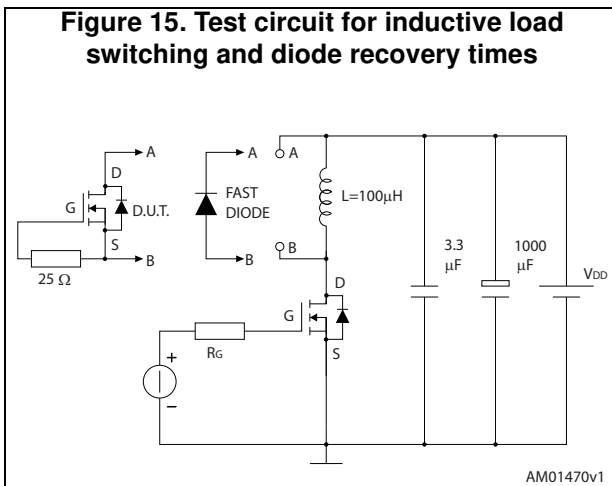
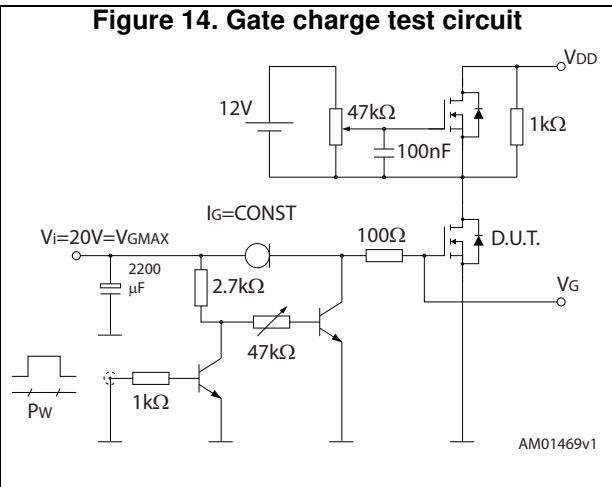
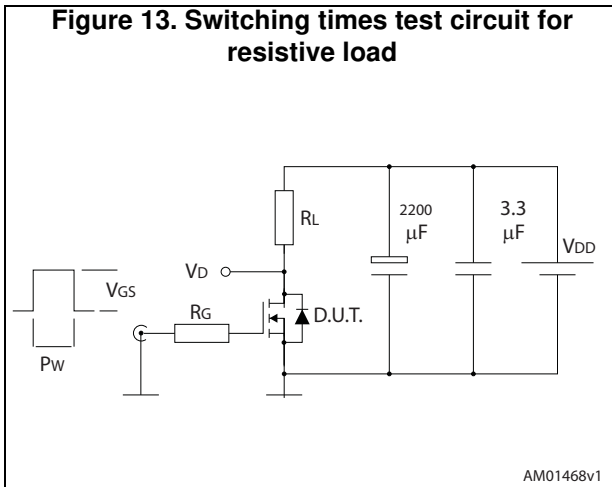



## 4 Package information

In order to meet environmental requirements, ST offers these devices in different grades of ECOPACK® packages, depending on their level of environmental compliance. ECOPACK® specifications, grade definitions and product status are available at: [www.st.com](http://www.st.com). ECOPACK® is an ST trademark.

### 4.1 D<sup>2</sup>PAK package information

Figure 19. D<sup>2</sup>PAK (TO-263) type A package outline

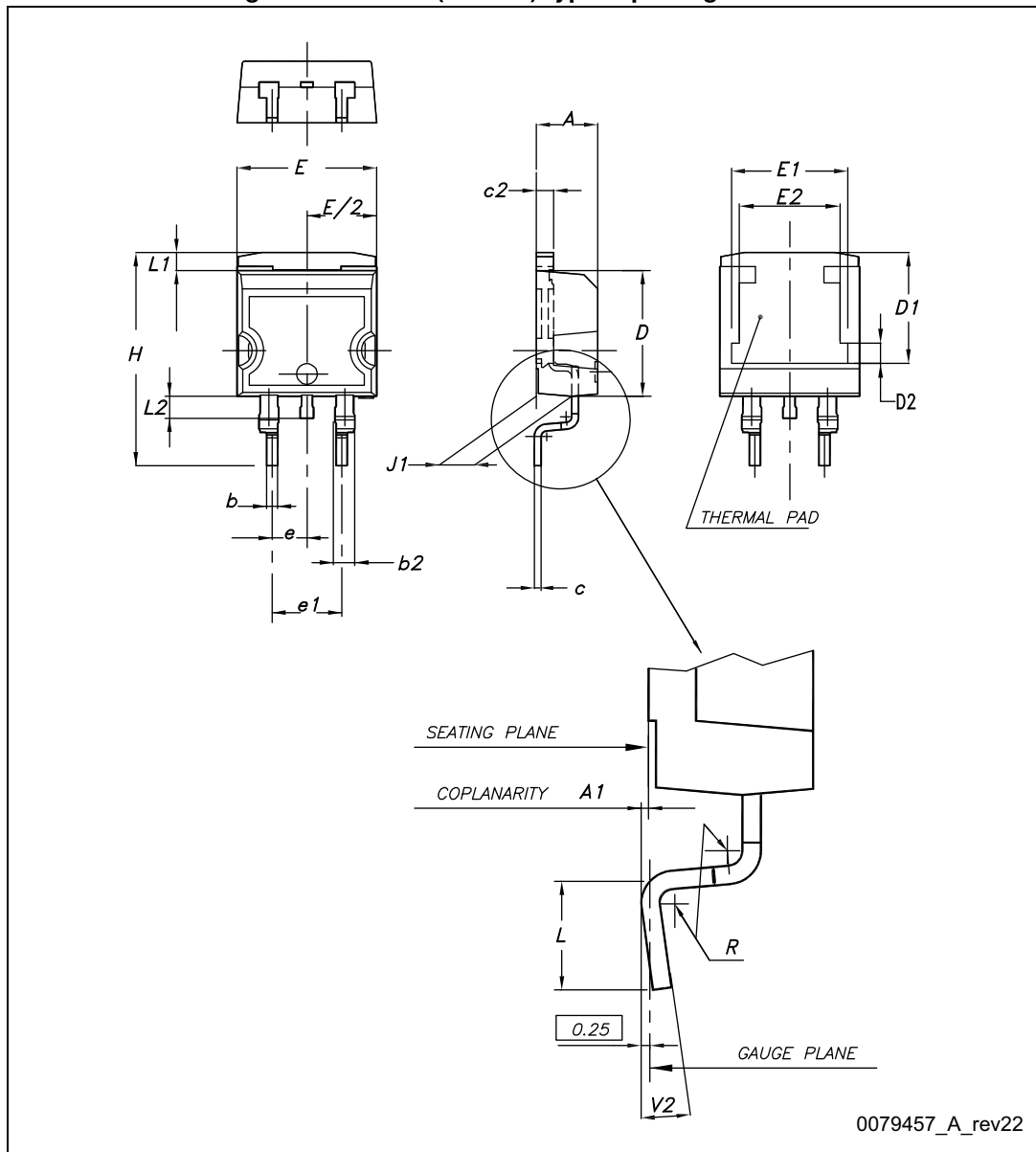
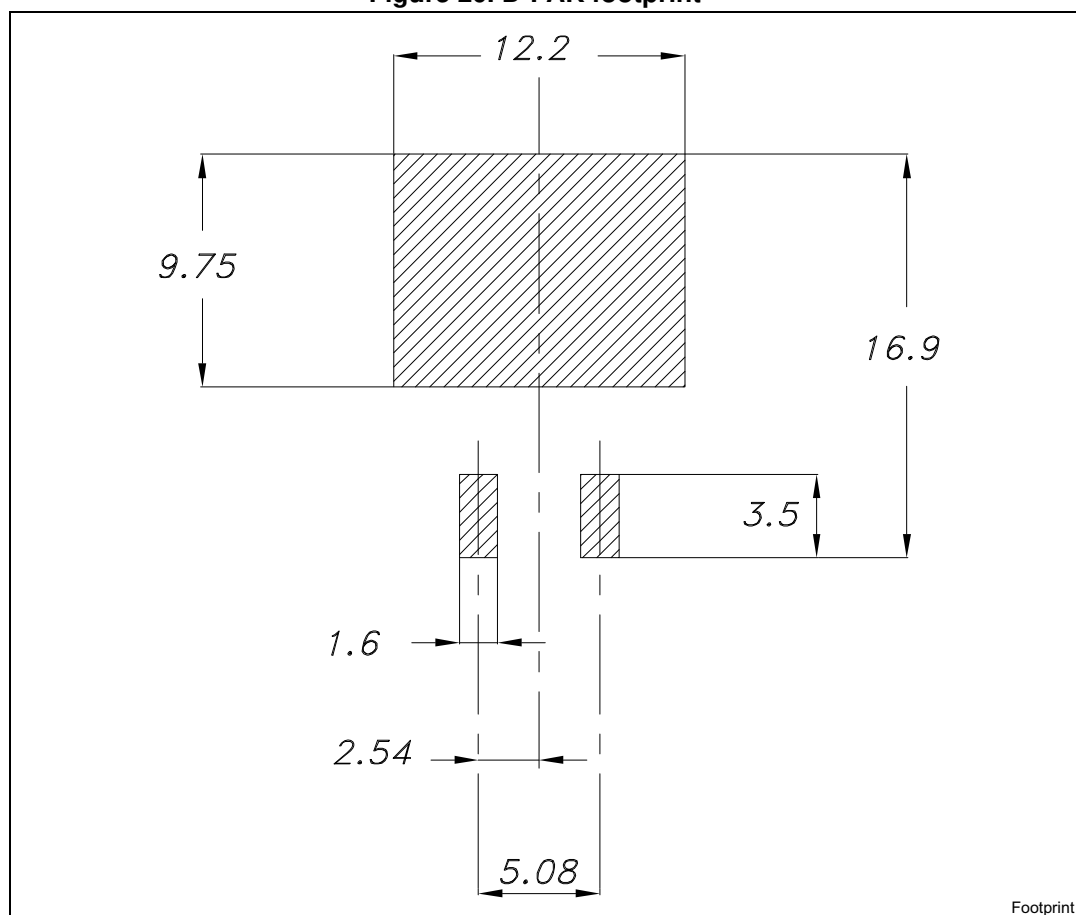

Table 9. D<sup>2</sup>PAK (TO-263) type A package mechanical data

Dim.	mm		
	Min.	Typ.	Max.
A	4.40		4.60
A1	0.03		0.23
b	0.70		0.93
b2	1.14		1.70
c	0.45		0.60
c2	1.23		1.36
D	8.95		9.35
D1	7.50	7.75	8.00
D2	1.10	1.30	1.50
E	10.00		10.40
E1	8.50	8.70	8.90
E2	6.85	7.05	7.25
e		2.54	
e1	4.88		5.28
H	15.00		15.85
J1	2.49		2.69
L	2.29		2.79
L1	1.27		1.40
L2	1.30		1.75
R		0.4	
V2	0°		8°

Figure 20. D<sup>2</sup>PAK footprint<sup>(a)</sup>



a. All dimension are in millimeters

### 4.2 TO-220 type A package information

Figure 21. TO-220 type A package outline

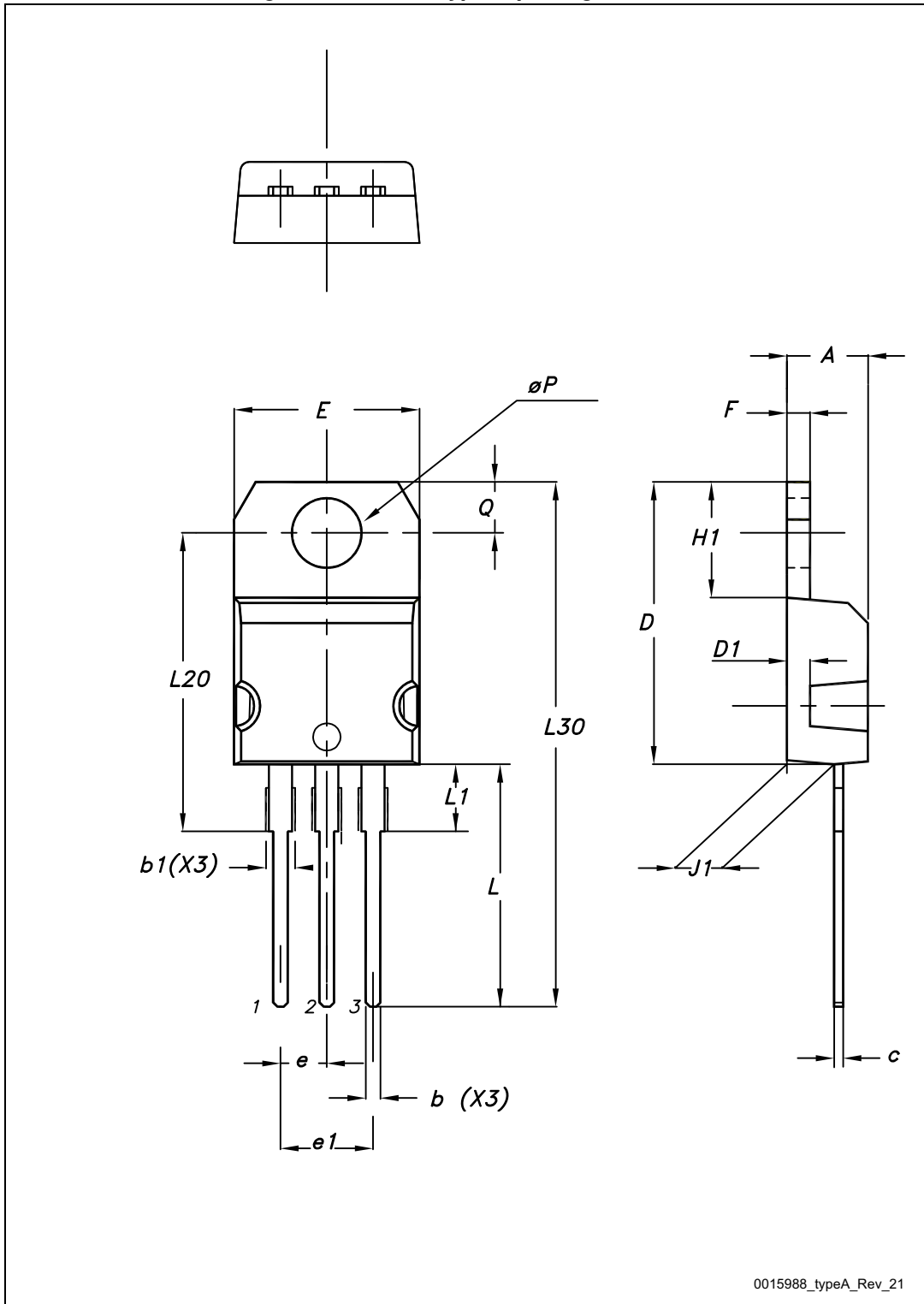

Table 10. TO-220 type A mechanical data

Dim.	mm		
	Min.	Typ.	Max.
A	4.40		4.60
b	0.61		0.88
b1	1.14		1.55
c	0.48		0.70
D	15.25		15.75
D1		1.27	
E	10.00		10.40
e	2.40		2.70
e1	4.95		5.15
F	1.23		1.32
H1	6.20		6.60
J1	2.40		2.72
L	13.00		14.00
L1	3.50		3.93
L20		16.40	
L30		28.90	
øP	3.75		3.85
Q	2.65		2.95

### 4.3 TO-220 type B package information

Figure 22. TO-220 type B package outline

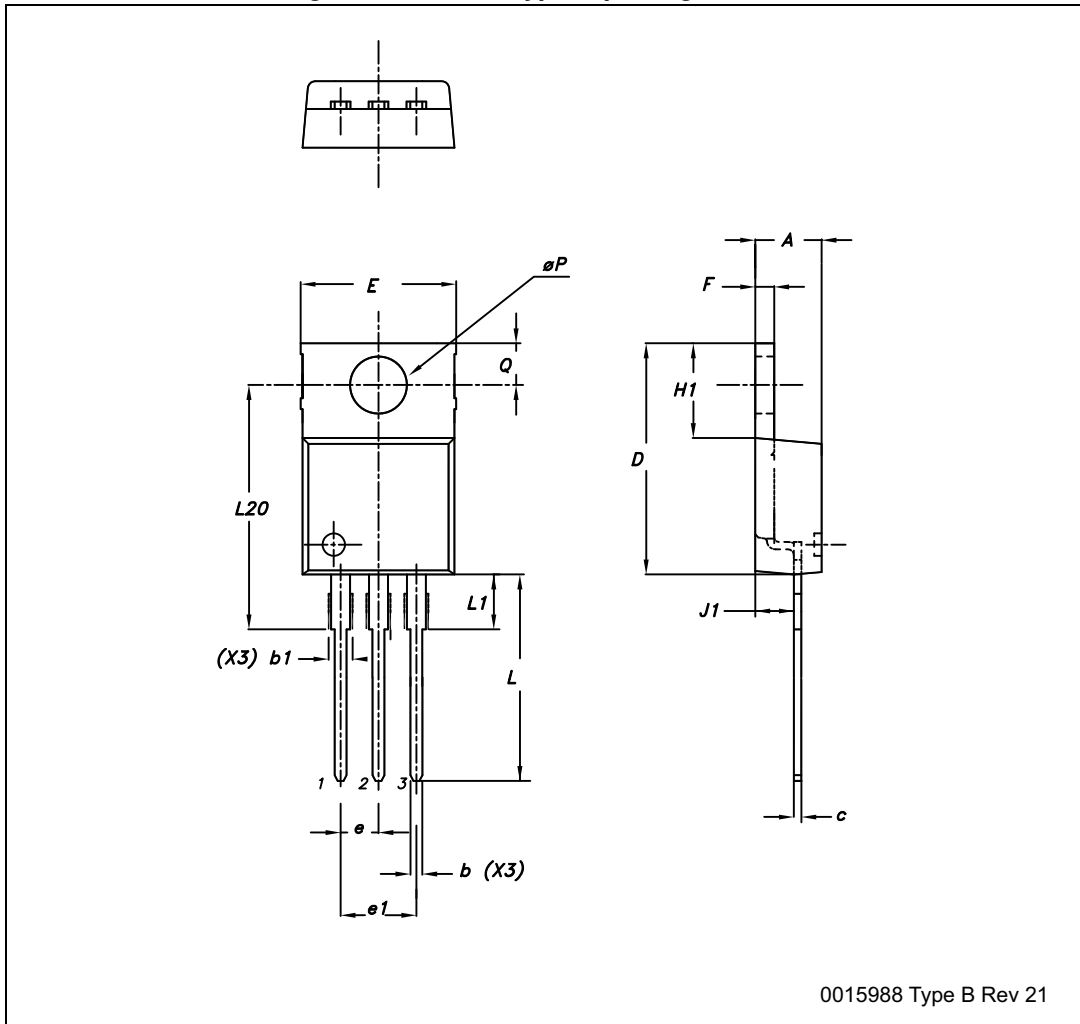

Table 11. TO-220 type B package mechanical data

Dim.	mm		
	Min.	Typ.	Max.
A	4.30		4.60
b	0.70		0.89
b1	1.19		1.35
c	0.31		0.46
D	14.80		15.10
E	10.20		10.37
e		2.54	
e1	5.00		5.14
F	1.21		1.32
H1	6.20		6.40
J1		2.66	
L	13.70		14.00
L1	3.40		3.94
L20		15.87	
øP	3.78		3.89
Q	2.69		2.80

# 5 Packing information

Figure 23. Tape

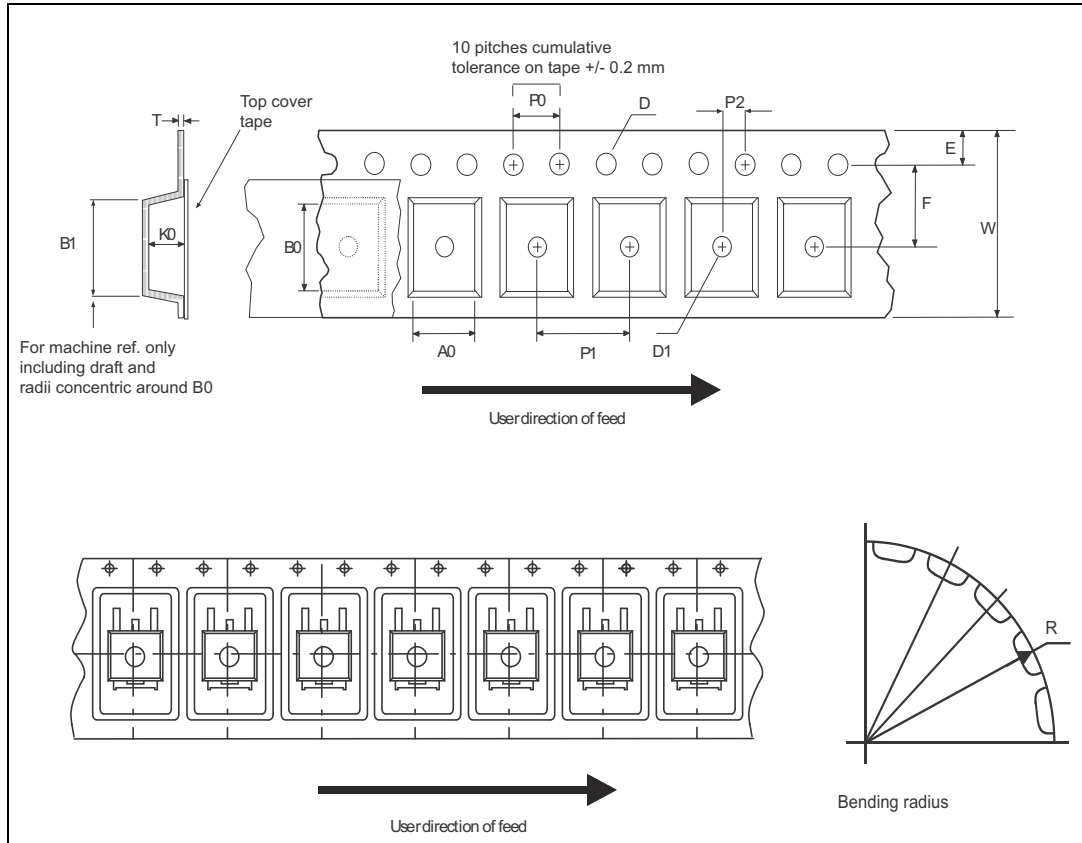



Figure 24. Reel

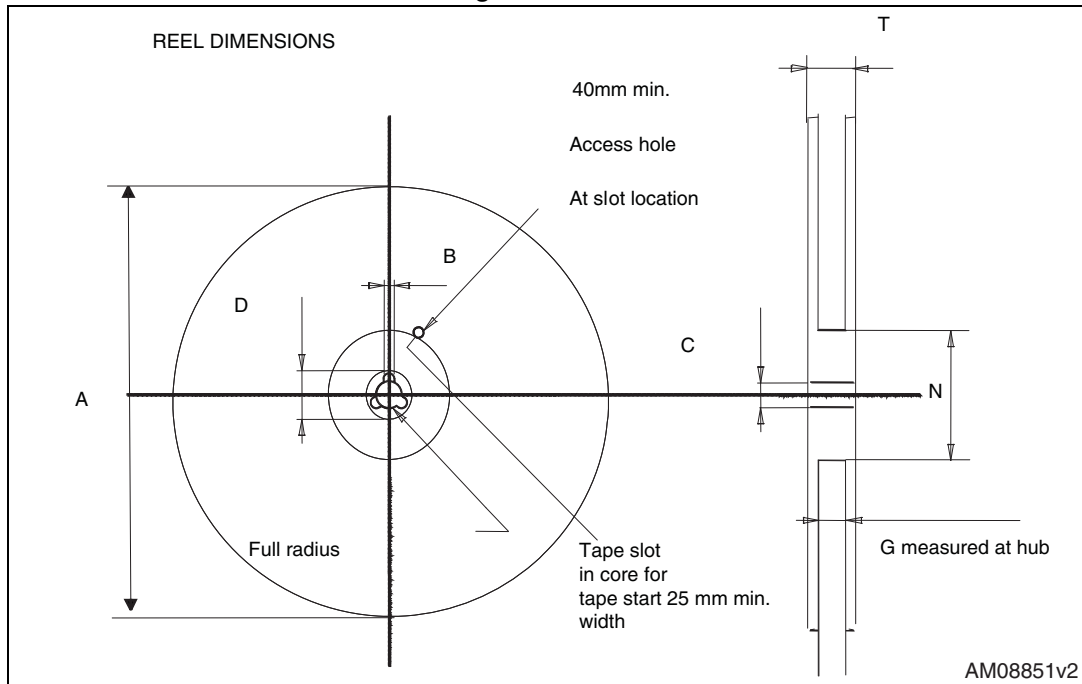

Table 12. D<sup>2</sup>PAK (TO-263) tape and reel mechanical data

Tape			Reel		
Dim.	mm		Dim.	mm	
	Min.	Max.		Min.	Max.
A0	10.5	10.7	A		330
B0	15.7	15.9	B	1.5	
D	1.5	1.6	C	12.8	13.2
D1	1.59	1.61	D	20.2	
E	1.65	1.85	G	24.4	26.4
F	11.4	11.6	N	100	
K0	4.8	5.0	T		30.4
P0	3.9	4.1			
P1	11.9	12.1	Base qty		1000
P2	1.9	2.1	Bulk qty		1000
R	50				
T	0.25	0.35			
W	23.7	24.3			

## 6 Revision history

Figure 25. Document revision history

Date	Revision	Changes
19-Jul-2016	1	First release

**IMPORTANT NOTICE – PLEASE READ CAREFULLY**

STMicroelectronics NV and its subsidiaries ("ST") reserve the right to make changes, corrections, enhancements, modifications, and improvements to ST products and/or to this document at any time without notice. Purchasers should obtain the latest relevant information on ST products before placing orders. ST products are sold pursuant to ST's terms and conditions of sale in place at the time of order acknowledgement.

Purchasers are solely responsible for the choice, selection, and use of ST products and ST assumes no liability for application assistance or the design of Purchasers' products.

No license, express or implied, to any intellectual property right is granted by ST herein.

Resale of ST products with provisions different from the information set forth herein shall void any warranty granted by ST for such product.

ST and the ST logo are trademarks of ST. All other product or service names are the property of their respective owners.

Information in this document supersedes and replaces information previously supplied in any prior versions of this document.

© 2016 STMicroelectronics – All rights reserved