

N-channel 800 V, 2.1 Ω typ., 3 A MDmesh™ K5 Power MOSFETs
in DPAK, TO-220FP, TO-220 and IPAK packages

Datasheet - production data

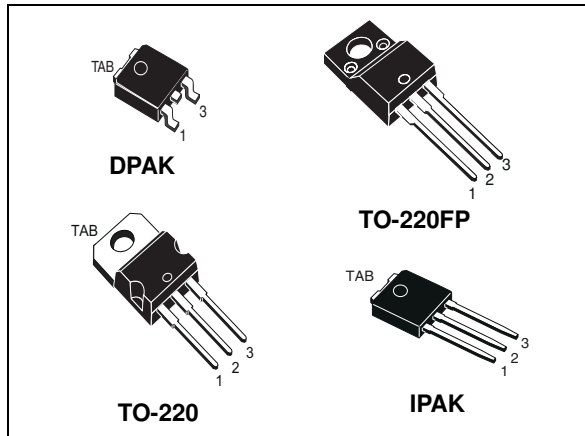
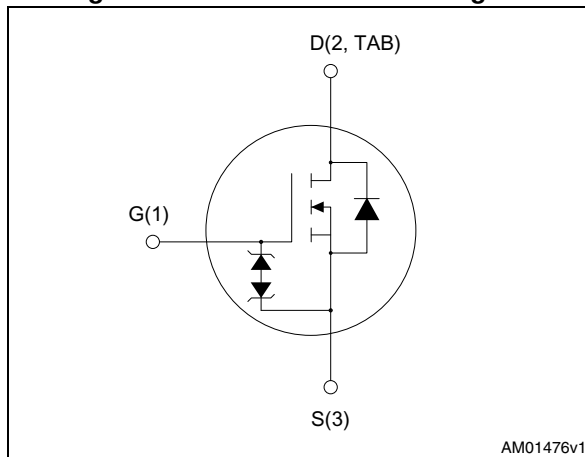

Figure 1. Internal schematic diagram



Features

Order code	V_{DS}	$R_{DS(on)}$ max.	I_D	P_{TOT}
STD4N80K5	800 V	2.5 Ω	3 A	60 W
STF4N80K5				20 W
STP4N80K5				60 W
STU4N80K5				

- Industry's lowest $R_{DS(on)}$ x area
- Industry's best figure of merit (FoM)
- Ultra low gate charge
- 100% avalanche tested
- Zener-protected

Applications

- Switching applications

Description

These very high voltage N-channel Power MOSFETs are designed using MDmesh™ K5 technology based on an innovative proprietary vertical structure. The result is a dramatic reduction in on-resistance and ultra-low gate charge for applications requiring superior power density and high efficiency.

Table 1. Device summary

Order code	Marking	Packages	Packaging
STD4N80K5	4N80K5	DPAK	Tape and reel
STF4N80K5		TO-220FP	Tube
STP4N80K5		TO-220	
STU4N80K5		IPAK	

Contents

- 1 Electrical ratings 3**
- 2 Electrical characteristics 4**
 - 2.1 Electrical characteristics (curves) 6
- 3 Test circuits 9**
- 4 Package information 10**
 - 4.1 DPAK(TO-252), package information11
 - 4.2 TO-220FP, package information 14
 - 4.3 TO-220, package information 16
 - 4.4 IPAK(TO-251), package information 18
- 5 Packaging mechanical data 20**
- 6 Revision history 22**

1 Electrical ratings

Table 2. Absolute maximum ratings

Symbol	Parameter	Value			Unit
		DPAK, IPAK	TO-220FP	TO-220	
V_{DS}	Drain-source voltage	800			V
V_{GS}	Gate- source voltage	±30			V
I_D	Drain current (continuous) at $T_C = 25\text{ °C}$	3	3 ⁽¹⁾	3	A
I_D	Drain current (continuous) at $T_C = 100\text{ °C}$	1.7	1.7 ⁽¹⁾	1.7	A
$I_{DM}^{(2)}$	Drain current (pulsed)	12	12 ⁽¹⁾	12	A
P_{TOT}	Total dissipation at $T_C = 25\text{ °C}$	60	20	60	W
I_{AR}	Avalanche current, repetitive or not-repetitive (pulse width limited by T_J max)	1			A
E_{AS}	Single pulse avalanche energy (starting $T_J = 25\text{ °C}$, $I_D = I_{AR}$, $V_{DD} = 50\text{ V}$)	74.5			mJ
$dv/dt^{(3)}$	Peak diode recovery voltage slope	4.5			V/ns
$dv/dt^{(4)}$	MOSFET dv/dt ruggedness	50			V/ns
V_{ISO}	Insulation withstand voltage (RMS) from all three leads to external heat sink ($t = 1\text{ s}$, $T_C = 25\text{ °C}$)		2500		V
T_J	Operating junction temperature	-55 to 150			°C
T_{stg}	Storage temperature				°C

1. Limited by maximum junction temperature
2. Pulse width limited by safe operating area
3. $I_{SD} < 3\text{ A}$, $di/dt < 100\text{ A}/\mu\text{s}$, $V_{DS(peak)} \leq V_{(BR)DSS}$
4. $V_{DS} \leq 640\text{ V}$

Table 3. Thermal data

Symbol	Parameter	Value			Unit
		DPAK, IPAK	TO-220FP	TO-220	
$R_{thj-case}$	Thermal resistance junction-case max	2.08	6.25	2.08	°C/W
$R_{thj-amb}$	Thermal resistance junction-ambient max		62.5		°C/W
$R_{thj-pcb}^{(1)}$	Thermal resistance junction-pcb max	50			°C/W

1. When mounted on 1inch² FR-4 board, 2 oz Cu

2 Electrical characteristics

(T_{case} = 25 °C unless otherwise specified)

Table 4. On /off states

Symbol	Parameter	Test conditions	Min.	Typ.	Max.	Unit
V _{(BR)DSS}	Drain-source breakdown voltage	I _D = 1 mA, V _{GS} = 0	800			V
I _{DSS}	Zero gate voltage drain current (V _{GS} = 0)	V _{DS} = 800 V			1	μA
		V _{DS} = 800 V, T _C = 125 °C			50	μA
I _{GSS}	Gate-body leakage current (V _{DS} = 0)	V _{GS} = ± 20 V			±10	μA
V _{GS(th)}	Gate threshold voltage	V _{DS} = V _{GS} , I _D = 100 μA	3	4	5	V
R _{DS(on)}	Static drain-source on-resistance	V _{GS} = 10 V, I _D = 1.5 A		2.1	2.5	Ω

Table 5. Dynamic

Symbol	Parameter	Test conditions	Min.	Typ.	Max.	Unit
C _{iss}	Input capacitance	V _{DS} = 100 V, f = 1 MHz, V _{GS} = 0	-	175	-	pF
C _{oss}	Output capacitance		-	18	-	pF
C _{rss}	Reverse transfer capacitance		-	0.5	-	pF
C _{o(tr)} ⁽¹⁾	Equivalent capacitance time related	V _{DS} = 0 to 640 V, V _{GS} = 0	-	26	-	pF
C _{o(er)} ⁽²⁾	Equivalent capacitance energy related	V _{DS} = 0 to 640 V, V _{GS} = 0	-	11	-	pF
R _g	Gate input resistance	f = 1 MHz, I _D = 0	-	15	-	Ω
Q _g	Total gate charge	V _{DD} = 640 V, I _D = 3 A, V _{GS} = 10 V (see Figure 19)	-	10.5	-	nC
Q _{gs}	Gate-source charge		-	2	-	nC
Q _{gd}	Gate-drain charge		-	7.5	-	nC

1. Time related is defined as a constant equivalent capacitance giving the same charging time as C_{oss} when V_{DS} increases from 0 to 80% V_{DSS}
2. Energy related is defined as a constant equivalent capacitance giving the same stored energy as C_{oss} when V_{DS} increases from 0 to 80% V_{DSS}

Table 6. Switching times

Symbol	Parameter	Test conditions	Min.	Typ.	Max.	Unit
$t_{d(on)}$	Turn-on delay time	$V_{DD} = 400\text{ V}$, $I_D = 1.5\text{ A}$, $R_G = 4.7\ \Omega$, $V_{GS} = 10\text{ V}$ (see Figure 18)	-	16.5	-	ns
t_r	Rise time		-	15	-	ns
$t_{d(off)}$	Turn-off-delay time		-	36	-	ns
t_f	Fall time		-	21	-	ns

Table 7. Source drain diode

Symbol	Parameter	Test conditions	Min.	Typ.	Max.	Unit
I_{SD}	Source-drain current		-		3	A
$I_{SDM}^{(1)}$	Source-drain current (pulsed)				12	A
$V_{SD}^{(2)}$	Forward on voltage	$I_{SD} = 3\text{ A}$, $V_{GS} = 0$	-		1.5	V
t_{rr}	Reverse recovery time	$I_{SD} = 3\text{ A}$, $di/dt = 100\text{ A}/\mu\text{s}$ $V_{DD} = 60\text{ V}$ (see Figure 20)	-	242		ns
Q_{rr}	Reverse recovery charge		-	1.42		μC
I_{RRM}	Reverse recovery current		-	12		A
t_{rr}	Reverse recovery time	$I_{SD} = 3\text{ A}$, $di/dt = 100\text{ A}/\mu\text{s}$ $V_{DD} = 60\text{ V}$ $T_J = 150\text{ }^\circ\text{C}$ (see Figure 20)	-	373		ns
Q_{rr}	Reverse recovery charge		-	1.98		μC
I_{RRM}	Reverse recovery current		-	10.5		A

1. Pulse width limited by safe operating area
2. Pulsed: pulse duration = 300 μs , duty cycle 1.5%

Table 8. Gate-source Zener diode

Symbol	Parameter	Test conditions	Min.	Typ.	Max.	Unit
$V_{(BR)GSO}$	Gate-source breakdown voltage	$I_{GS} = \pm 1\text{ mA}$, $I_D = 0$	30		-	V

The built-in back-to-back Zener diodes have been specifically designed to enhance the ESD capability of the device. The Zener voltage is appropriate for efficient and cost-effective intervention to protect the device integrity. These integrated Zener diodes thus eliminate the need for external components.

2.1 Electrical characteristics (curves)

Figure 2. Safe operating area for DPAK and IPAK

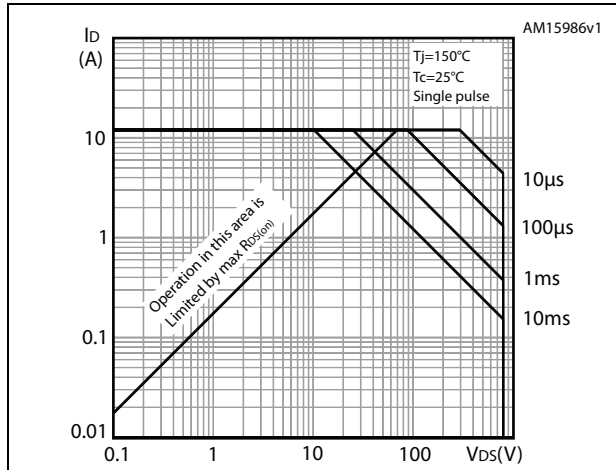

Figure 3. Thermal impedance for DPAK and IPAK

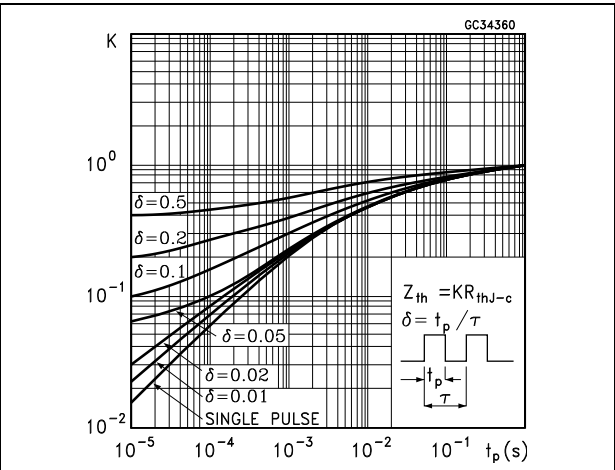

Figure 4. Safe operating area for TO-220FP

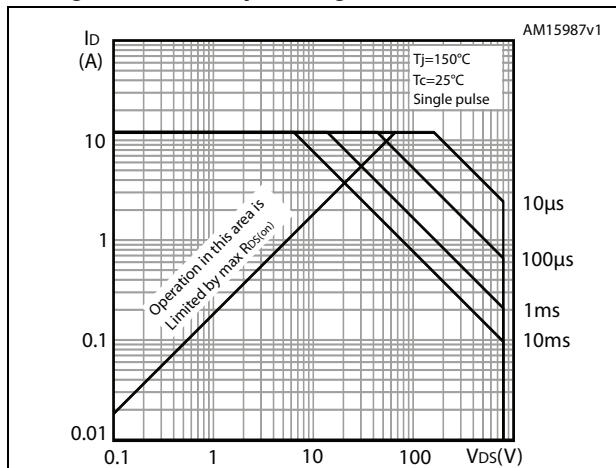

Figure 5. Thermal impedance for TO-220FP

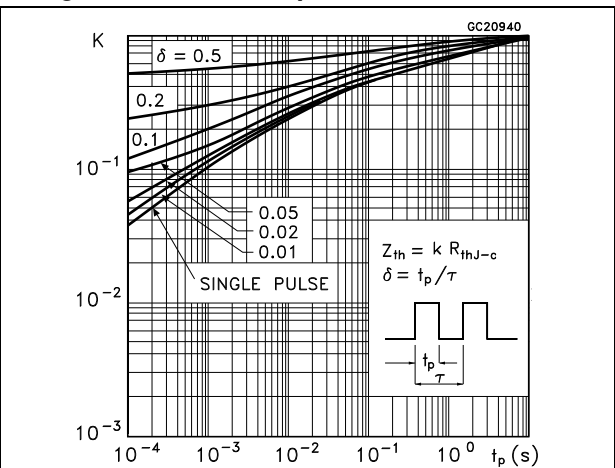

Figure 6. Safe operating area for TO-220

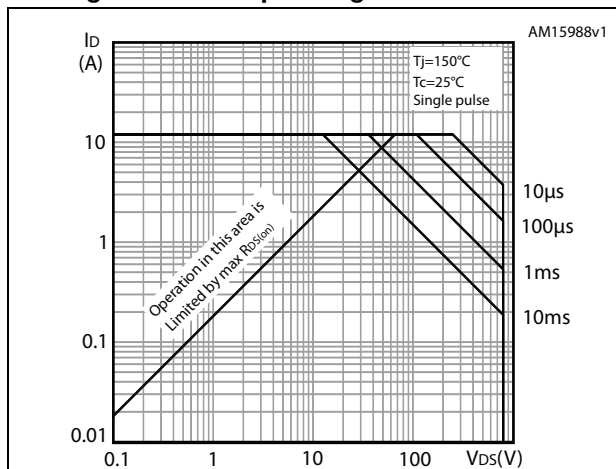

Figure 7. Thermal impedance for TO-220

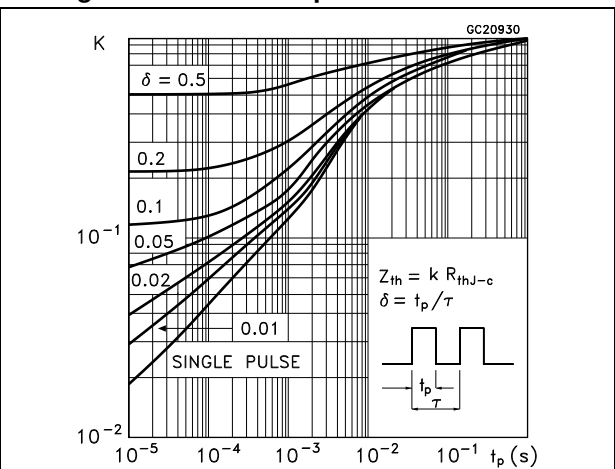

Figure 8. Output characteristics

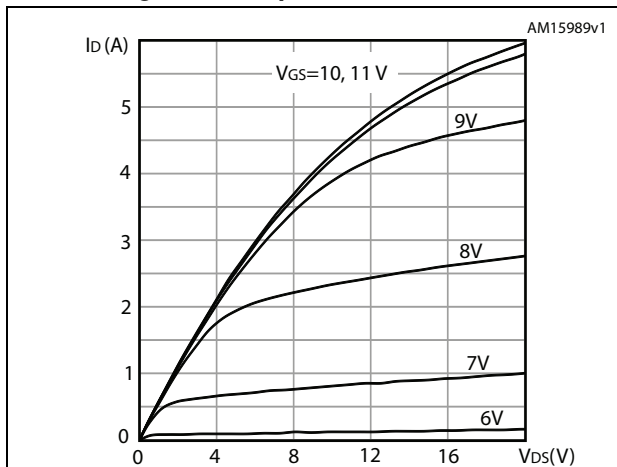

Figure 9. Transfer characteristics

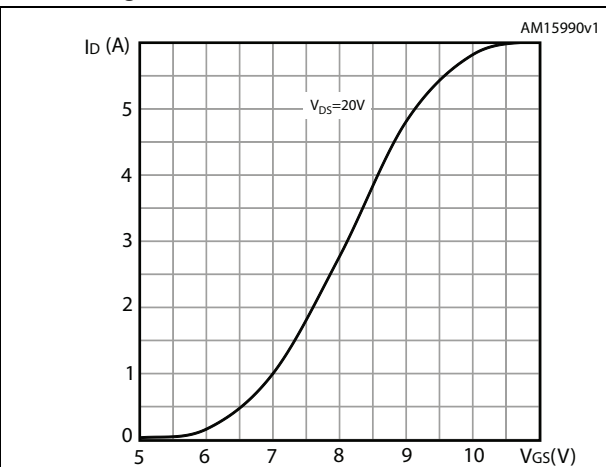

Figure 10. Gate charge vs gate-source voltage

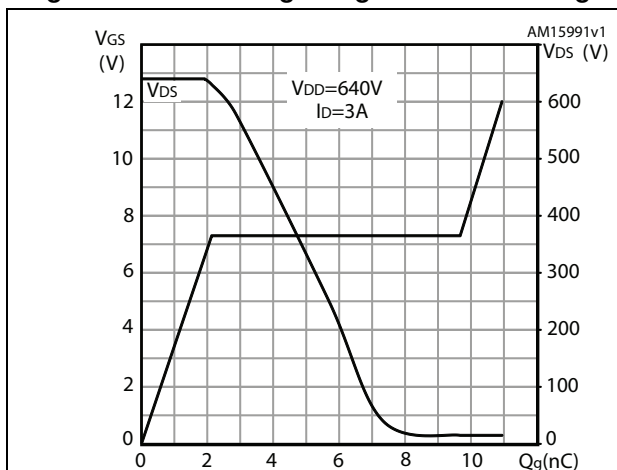

Figure 11. Static drain-source on-resistance

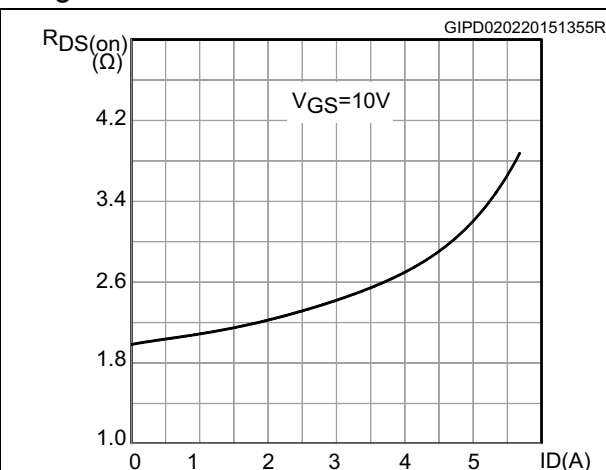

Figure 12. Capacitance variations

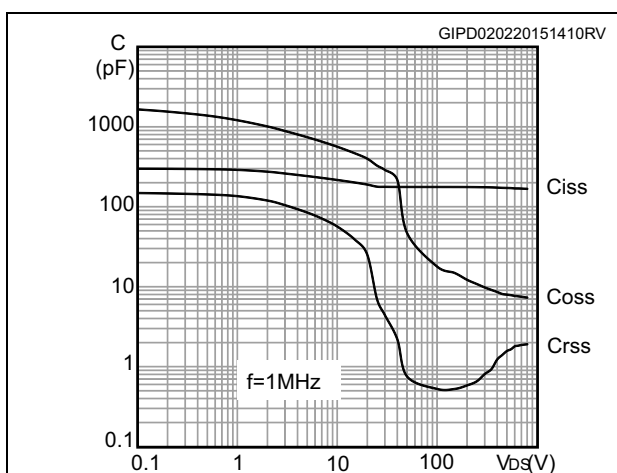

Figure 13. Normalized gate threshold voltage vs temperature

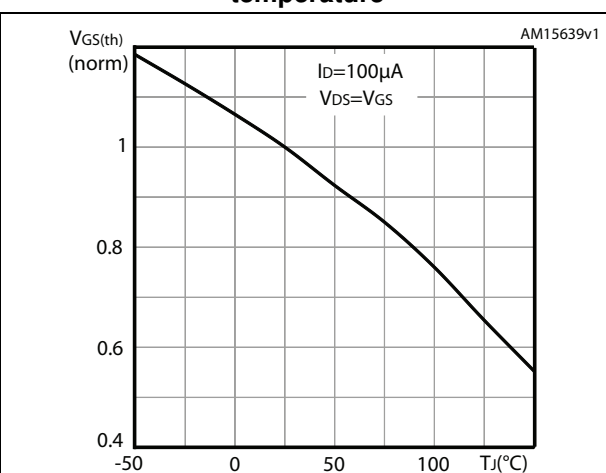

Figure 14. Normalized on-resistance vs temperature

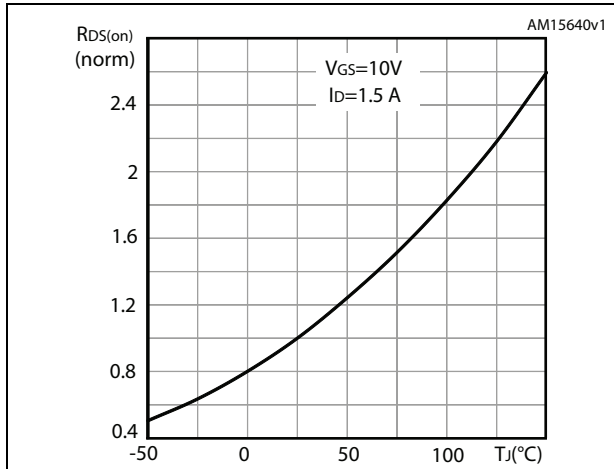

Figure 15. Source-drain diode forward characteristics

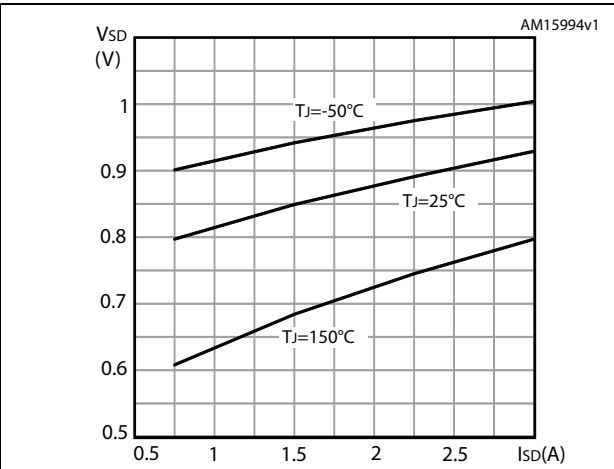

Figure 16. Normalized V_{DS} vs temperature

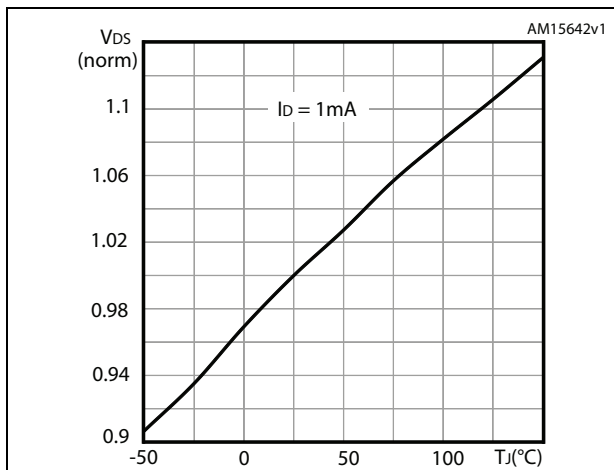
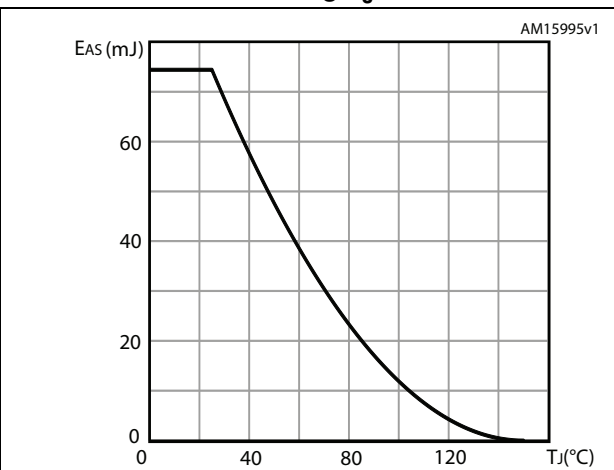

Figure 17. Maximum avalanche energy vs. starting T_J



3 Test circuits

Figure 18. Switching times test circuit for resistive load

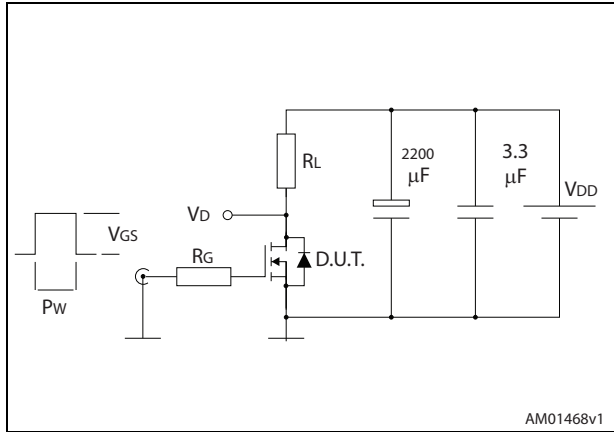

Figure 19. Gate charge test circuit

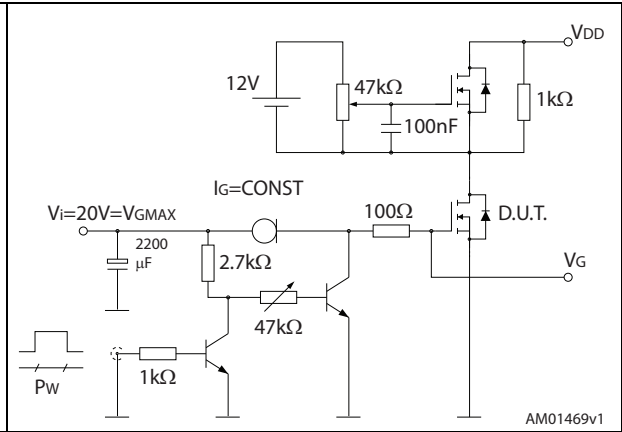

Figure 20. Test circuit for inductive load switching and diode recovery times

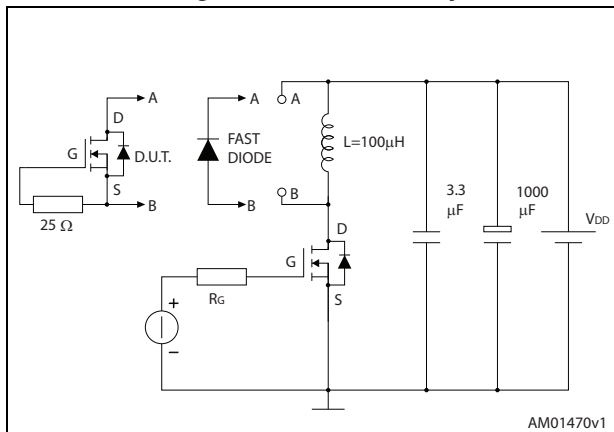

Figure 21. Unclamped inductive load test circuit

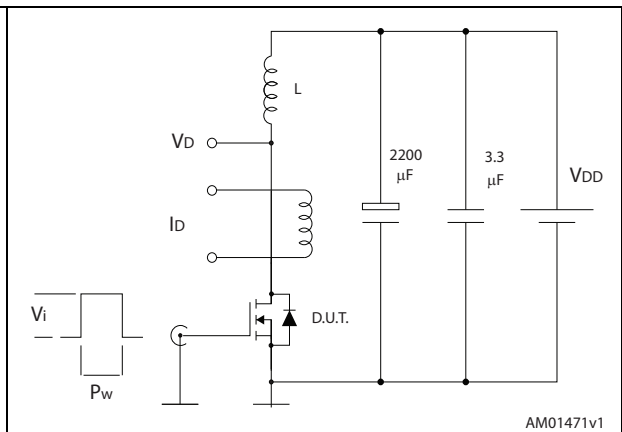

Figure 22. Unclamped inductive waveform

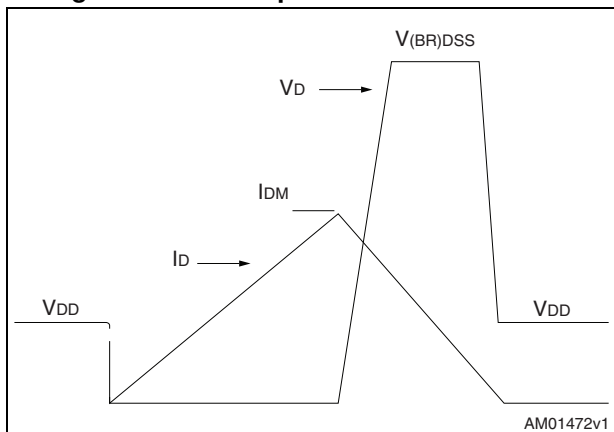
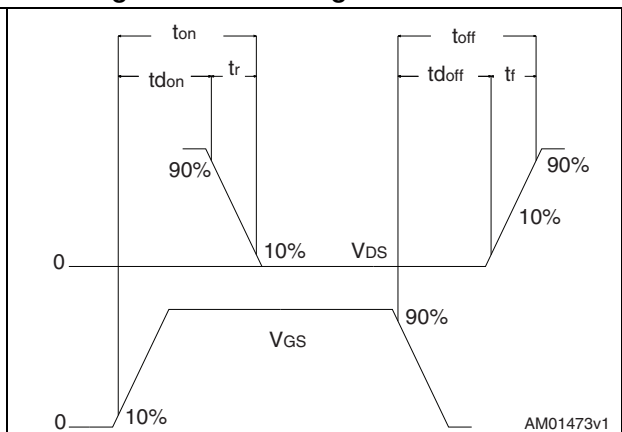

Figure 23. Switching time waveform



4 Package information

In order to meet environmental requirements, ST offers these devices in different grades of ECOPACK[®] packages, depending on their level of environmental compliance. ECOPACK[®] specifications, grade definitions and product status are available at: www.st.com. ECOPACK[®] is an ST trademark.

4.1 DPAK(TO-252), package information

Figure 24. DPAK (TO-252) type A outline

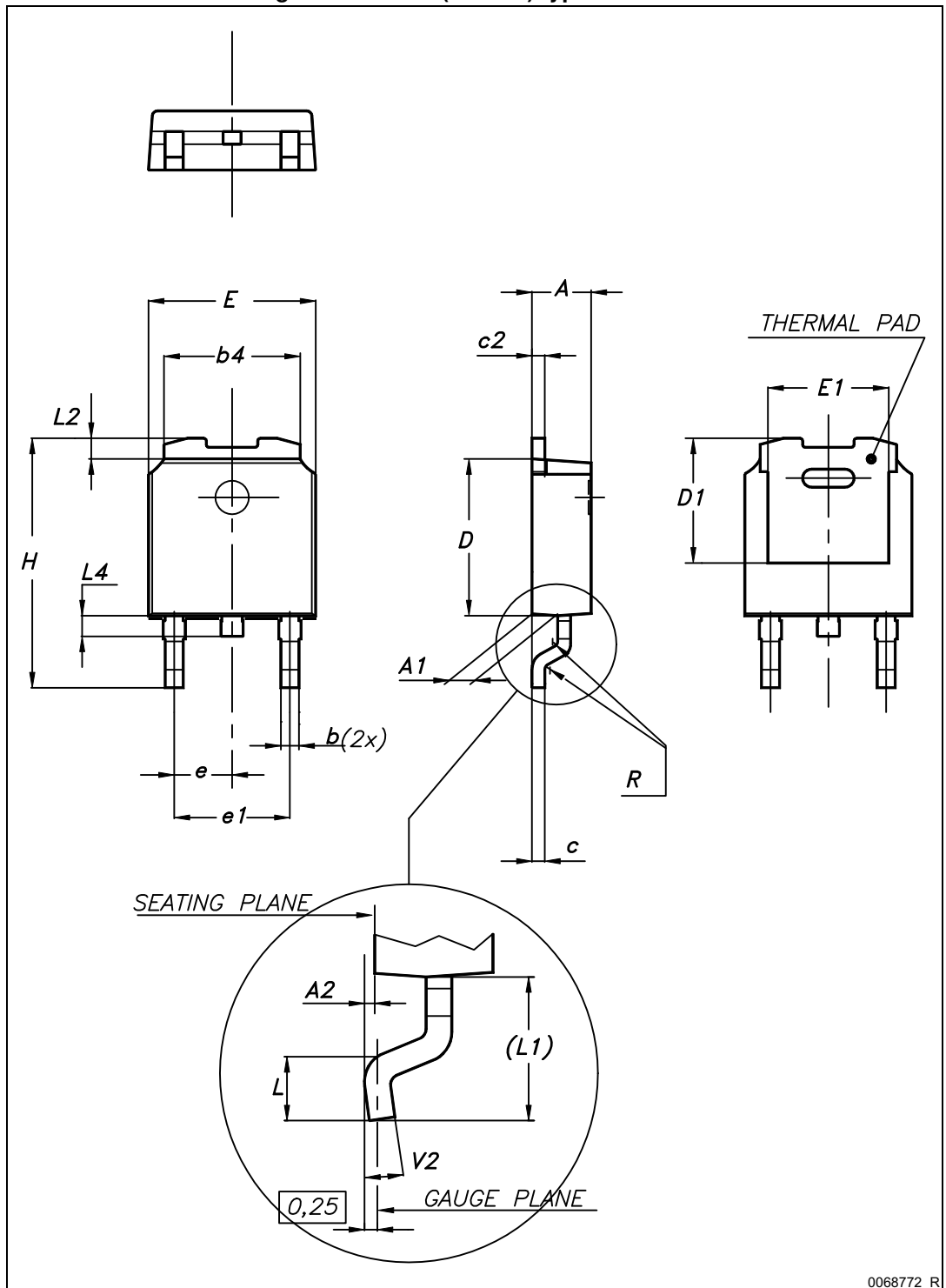

0068772_R

Figure 25. DPAK (TO-252) mechanical data

Dim.	mm		
	Min.	Typ.	Max.
A	2.20		2.40
A1	0.90		1.10
A2	0.03		0.23
b	0.64		0.90
b4	5.20		5.40
c	0.45		0.60
c2	0.48		0.60
D	6.00		6.20
D1		5.10	
E	6.40		6.60
E1		4.70	
e		2.28	
e1	4.40		4.60
H	9.35		10.10
L	1.00		1.50
L1		2.80	
L2		0.80	
L4	0.60		1.00
R		0.20	
V2	0°		8°

Figure 26. DPAK (TO-252) footprint (a)

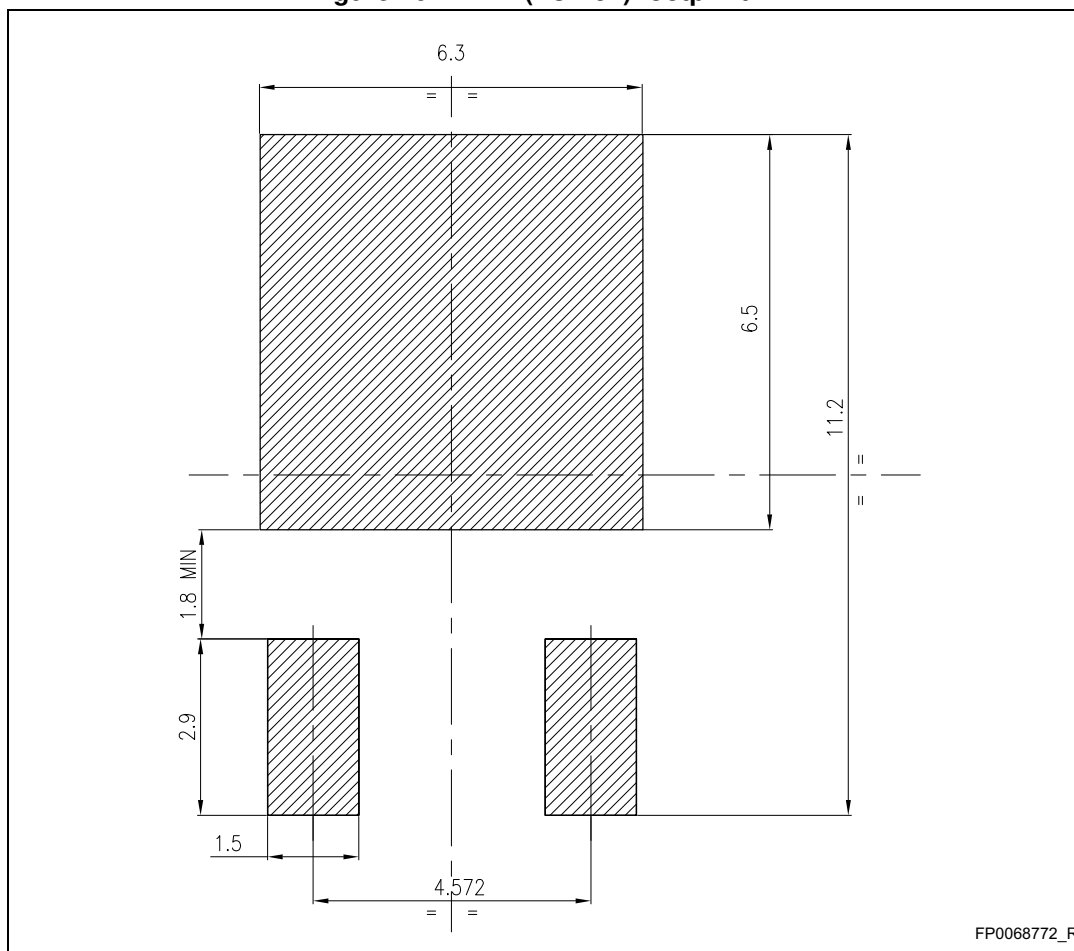

a. All dimensions are in millimeters

4.2 TO-220FP, package information

Figure 27. TO-220FP outline

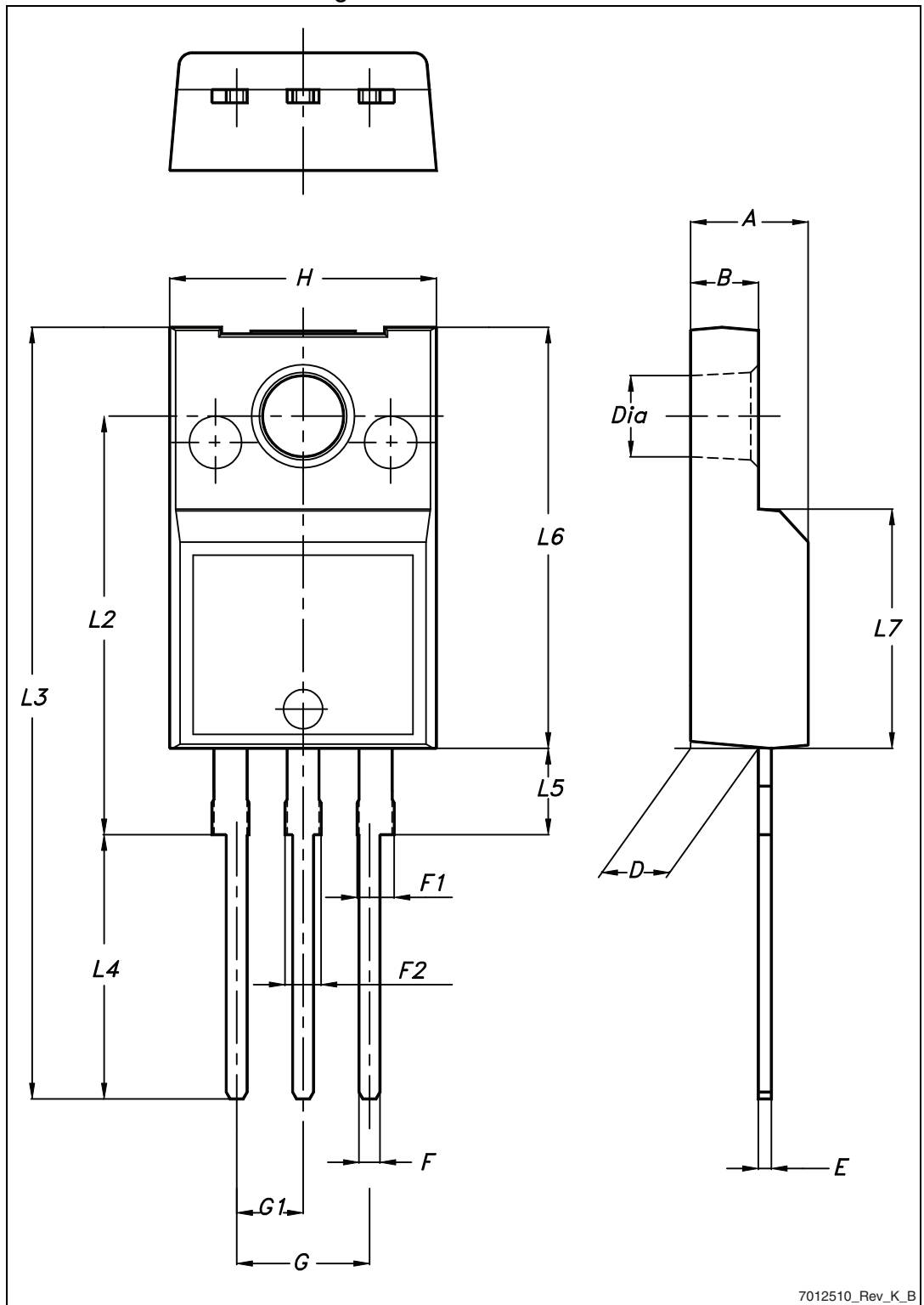

7012510_Rev_K_B

Table 9. TO-220FP mechanical data

Dim.	mm		
	Min.	Typ.	Max.
A	4.4		4.6
B	2.5		2.7
D	2.5		2.75
E	0.45		0.7
F	0.75		1
F1	1.15		1.70
F2	1.15		1.70
G	4.95		5.2
G1	2.4		2.7
H	10		10.4
L2		16	
L3	28.6		30.6
L4	9.8		10.6
L5	2.9		3.6
L6	15.9		16.4
L7	9		9.3
Dia	3		3.2

4.3 TO-220, package information

Figure 28. TO-220 type A outline

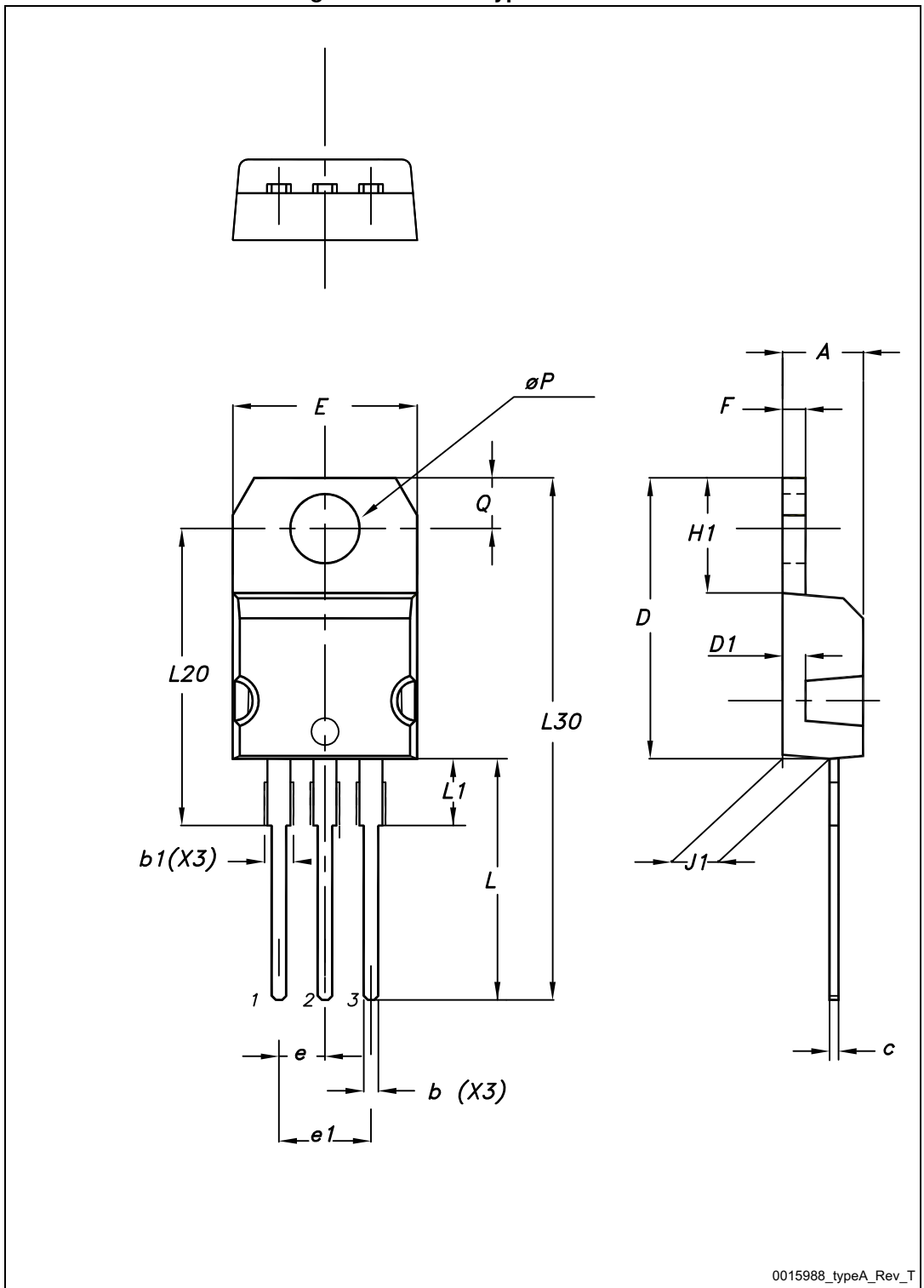

0015988_typeA_Rev_T

Table 10. TO-220 type A mechanical data

Dim.	mm		
	Min.	Typ.	Max.
A	4.40		4.60
b	0.61		0.88
b1	1.14		1.70
c	0.48		0.70
D	15.25		15.75
D1		1.27	
E	10		10.40
e	2.40		2.70
e1	4.95		5.15
F	1.23		1.32
H1	6.20		6.60
J1	2.40		2.72
L	13		14
L1	3.50		3.93
L20		16.40	
L30		28.90	
ØP	3.75		3.85
Q	2.65		2.95

4.4 IPAK(TO-251), package information

Figure 29. IPAK (TO-251) type A outline

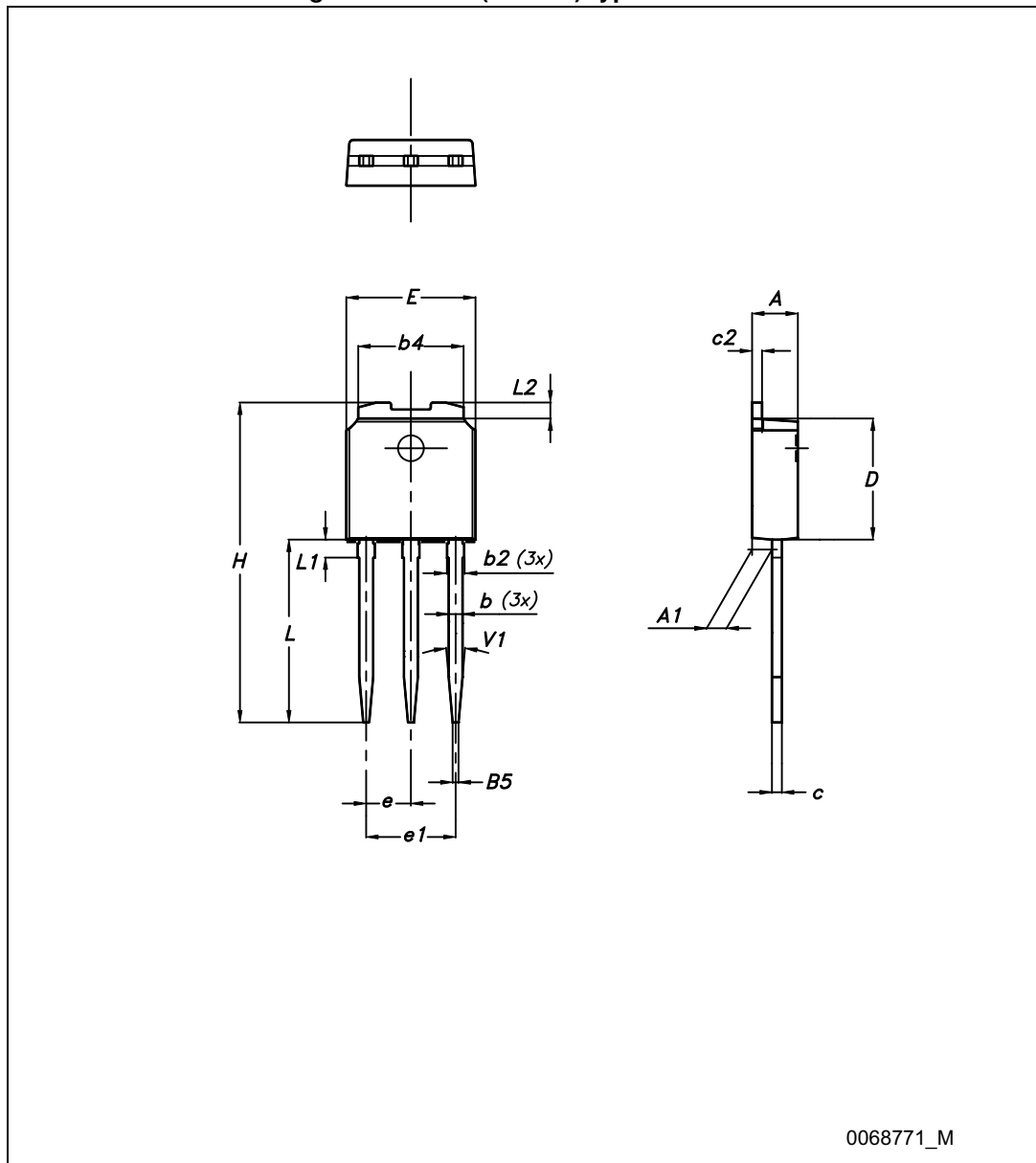

0068771_M

Table 11. IPAK (TO-251) type A mechanical data

DIM	mm.		
	min.	typ.	max.
A	2.20		2.40
A1	0.90		1.10
b	0.64		0.90
b2			0.95
b4	5.20		5.40
B5		0.30	
c	0.45		0.60
c2	0.48		0.60
D	6.00		6.20
E	6.40		6.60
e		2.28	
e1	4.40		4.60
H		16.10	
L	9.00		9.40
L1	0.80		1.20
L2		0.80	1.00
V1		10°	

5 Packaging mechanical data

Table 12. DPAK (TO-252) tape and reel mechanical data

Tape			Reel		
Dim.	mm		Dim.	mm	
	Min.	Max.		Min.	Max.
A0	6.8	7	A		330
B0	10.4	10.6	B	1.5	
B1		12.1	C	12.8	13.2
D	1.5	1.6	D	20.2	
D1	1.5		G	16.4	18.4
E	1.65	1.85	N	50	
F	7.4	7.6	T		22.4
K0	2.55	2.75			
P0	3.9	4.1	Base qty.		2500
P1	7.9	8.1	Bulk qty.		2500
P2	1.9	2.1			
R	40				
T	0.25	0.35			
W	15.7	16.3			

Figure 30. Tape for DPAK (TO-252)

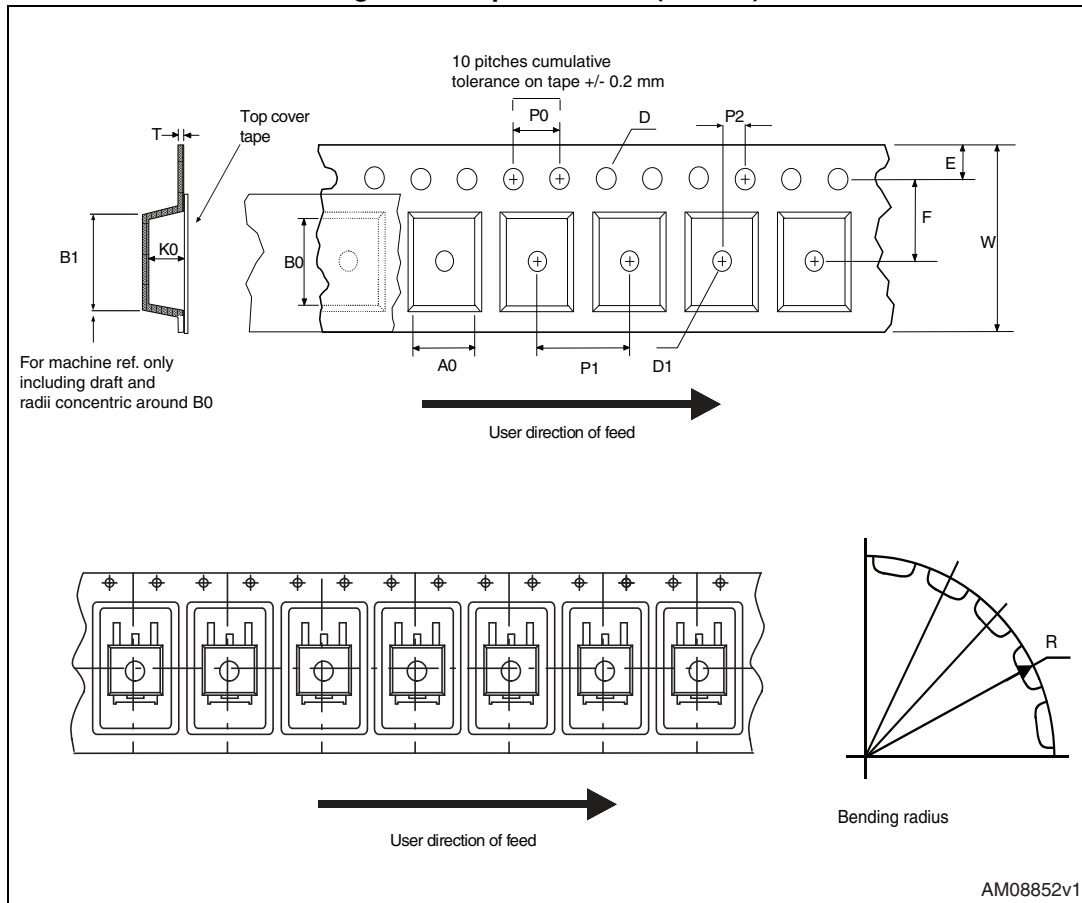
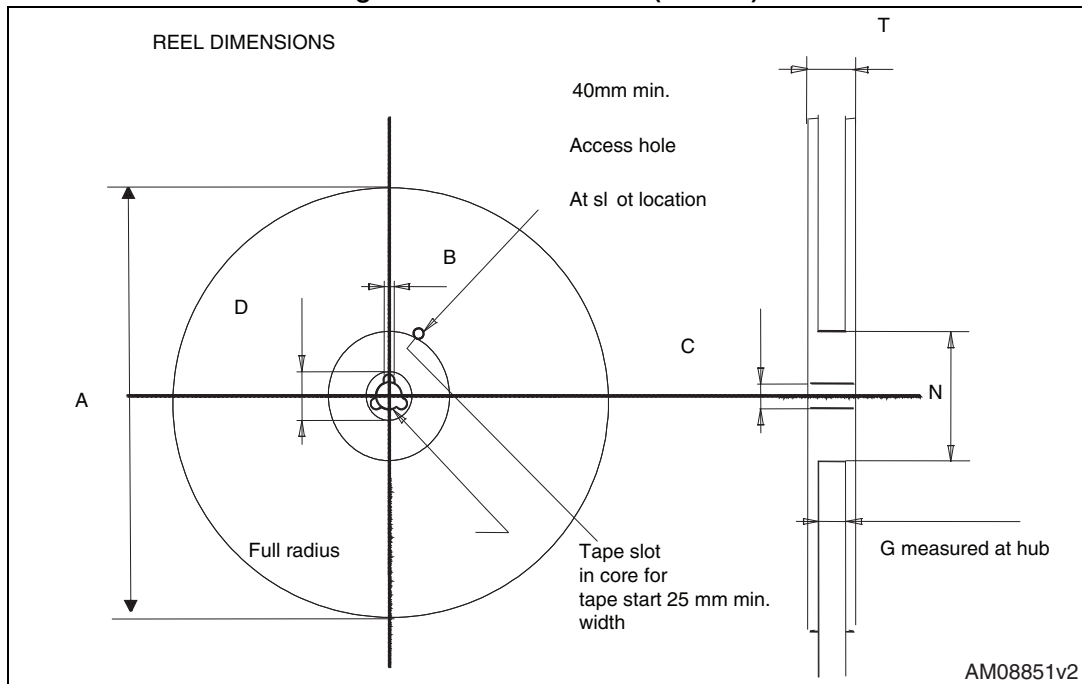

Figure 31. Reel for DPAK (TO-252)



6 Revision history

Table 13. Document revision history

Date	Revision	Changes
09-Aug-2013	1	First release
13-Dec-2013	2	<ul style="list-style-type: none">– Added: IPAK package– Added: Table 11 and Figure 29– Minor text changes
04-Feb-2015	3	<ul style="list-style-type: none">– Updated title and description in cover page.– Updated Table 2.: Absolute maximum ratings, Table 5.: Dynamic and Table 7.: Source drain diode.– Updated 4: Package information and 5: Packaging mechanical data.– Minor text changes.

IMPORTANT NOTICE – PLEASE READ CAREFULLY

STMicroelectronics NV and its subsidiaries ("ST") reserve the right to make changes, corrections, enhancements, modifications, and improvements to ST products and/or to this document at any time without notice. Purchasers should obtain the latest relevant information on ST products before placing orders. ST products are sold pursuant to ST's terms and conditions of sale in place at the time of order acknowledgement.

Purchasers are solely responsible for the choice, selection, and use of ST products and ST assumes no liability for application assistance or the design of Purchasers' products.

No license, express or implied, to any intellectual property right is granted by ST herein.

Resale of ST products with provisions different from the information set forth herein shall void any warranty granted by ST for such product.

ST and the ST logo are trademarks of ST. All other product or service names are the property of their respective owners.

Information in this document supersedes and replaces information previously supplied in any prior versions of this document.

© 2015 STMicroelectronics – All rights reserved