

## N-channel 525 V, 1.25 $\Omega$ typ., 4.4 A UltraFASTmesh™ Power MOSFETs in DPAK and TO-220FP packages

Datasheet - production data

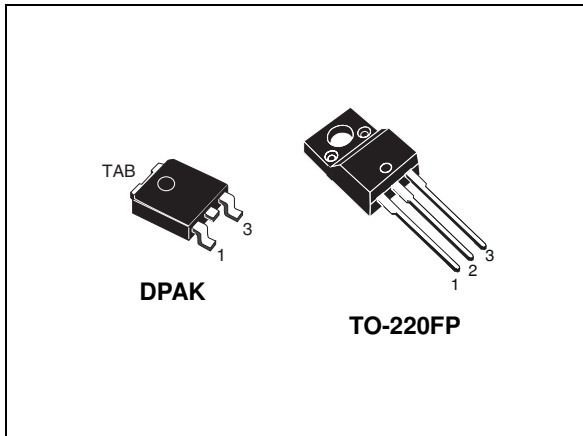
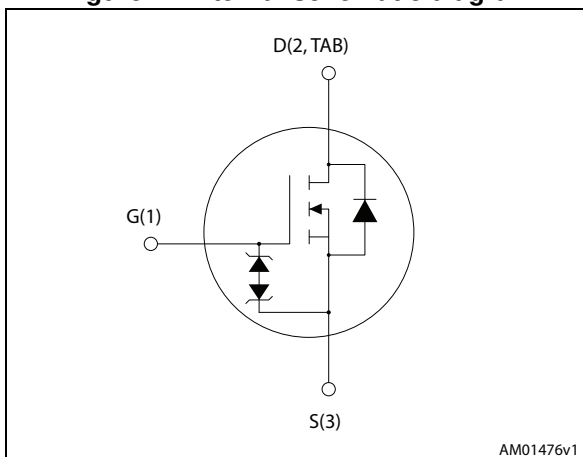

Figure 1. Internal schematic diagram



### Features

Order codes	$V_{DS}$	$R_{DS(on) \max}$	$I_D$	$P_{TOT}$
STD5N52U	525 V	1.5 $\Omega$	4.4 A	70 W
STF5N52U				25 W

- Outstanding dv/dt capability
- Gate charge minimized
- Very low intrinsic capacitances
- Very low  $R_{DS(on)}$
- Extremely low  $t_{rr}$

### Applications

- Switching applications

### Description

These devices are N-channel Power MOSFETs developed using UltraFASTmesh™ technology, which combines the advantages of reduced on-resistance, Zener gate protection and very high dv/dt capability with an enhanced fast body-drain recovery diode.

Table 1. Device summary

Order codes	Marking	Package	Packaging
STD5N52U	5N52U	DPAK	Tape and reel
STF5N52U		TO-220FP	Tube

# Contents

- 1      Electrical ratings ..... 3**
- 2      Electrical characteristics ..... 4**
  - 2.1    Electrical characteristics (curves) ..... 6
- 3      Test circuits ..... 9**
- 4      Package mechanical data ..... 10**
  - 4.1    DPAK, STD5N52U .....11
  - 4.2    TO-220FP, STF5N52U ..... 14
- 5      Packaging mechanical data ..... 16**
- 6      Revision history ..... 18**

# 1 Electrical ratings

**Table 2. Absolute maximum ratings**

Symbol	Parameter	Value		Unit
		DPAK	TO-220FP	
$V_{GS}$	Gate- source voltage	± 30		V
$I_D$	Drain current (continuous) at $T_C = 25\text{ °C}$	4.4		A
$I_D$	Drain current (continuous) at $T_C = 100\text{ °C}$	2.8		A
$I_{DM}^{(1)}$	Drain current (pulsed)	17.6		A
$P_{TOT}$	Total dissipation at $T_C = 25\text{ °C}$	70	25	W
$I_{AR}$	Avalanche current, repetitive or not-repetitive (pulse width limited by $T_J$ max)	4.4		A
$E_{AS}$	Single pulse avalanche energy (starting $T_J = 25\text{ °C}$ , $I_D = I_{AR}$ , $V_{DD} = 50\text{ V}$ )	170		mJ
$dv/dt^{(2)}$	Peak diode recovery voltage slope	20		V/ns
ESD	Gate-source human body model ( $R = 1.5\text{ k}\Omega$ , $C = 100\text{ pF}$ )	2.8		kV
$V_{ISO}$	Insulation withstand voltage (RMS) from all three leads to external heat sink ( $t=1\text{ s}; T_C=25\text{ °C}$ )	2500		V
$T_J$	Operating junction temperature	-55 to 150		°C
$T_{stg}$	Storage temperature			°C

1. Pulse width limited by safe operating area.
2.  $I_{SD} \leq 4.4\text{ A}$ ,  $di/dt \leq 400\text{ A}/\mu\text{s}$ , peak  $V_{DS} \leq V_{(BR)DSS}$

**Table 3. Thermal data**

Symbol	Parameter	Value		Unit
		DPAK	TO-220FP	
$R_{thj-case}$	Thermal resistance junction-case max	1.79	5	°C/W
$R_{thj-amb}$	Thermal resistance junction-ambient max		62.5	°C/W
$R_{thj-pcb}^{(1)}$	Thermal resistance junction-pcb	50		°C/W

1. When mounted on 1 inch<sup>2</sup> FR-4 board, 2oz Cu

## 2 Electrical characteristics

(T<sub>case</sub> = 25 °C unless otherwise specified).

**Table 4. On /off states**

Symbol	Parameter	Test conditions	Min.	Typ.	Max.	Unit
V <sub>(BR)DSS</sub>	Drain-source breakdown voltage (V <sub>GS</sub> = 0)	I <sub>D</sub> = 1 mA	525			V
I <sub>DSS</sub>	Zero gate voltage drain current (V <sub>GS</sub> = 0)	V <sub>DS</sub> = 525 V			10	μA
		V <sub>DS</sub> = 525 V, T <sub>C</sub> = 125 °C			500	μA
I <sub>GSS</sub>	Gate-body leakage current (V <sub>DS</sub> = 0)	V <sub>GS</sub> = 20 V			±10	μA
V <sub>GS(th)</sub>	Gate threshold voltage	V <sub>DS</sub> = V <sub>GS</sub> , I <sub>D</sub> = 50 μA	3	3.75	4.5	V
R <sub>DS(on)</sub>	Static drain-source on-resistance	V <sub>GS</sub> = 10 V, I <sub>D</sub> = 2.2 A		1.25	1.5	Ω

**Table 5. Dynamic**

Symbol	Parameter	Test conditions	Min.	Typ.	Max.	Unit
C <sub>iss</sub>	Input capacitance	V <sub>DS</sub> = 25 V, f = 1 MHz, V <sub>GS</sub> = 0	-	529	-	pF
C <sub>oss</sub>	Output capacitance		-	71	-	pF
C <sub>rss</sub>	Reverse transfer capacitance		-	13.4	-	pF
C <sub>o(tr)</sub> <sup>(1)</sup>	Equivalent capacitance time related	V <sub>DS</sub> = 0 to 420 V, V <sub>GS</sub> = 0	-	11	-	pF
R <sub>g</sub>	Gate input resistance	f = 1 MHz open drain	-	6	-	Ω
Q <sub>g</sub>	Total gate charge	V <sub>DD</sub> = 416 V, I <sub>D</sub> = 4.4 A, V <sub>GS</sub> = 10 V (see Figure 17)	-	16.9	-	nC
Q <sub>gs</sub>	Gate-source charge		-	4.2	-	nC
Q <sub>gd</sub>	Gate-drain charge		-	8.4	-	nC

1. C<sub>oss,eq</sub> time related is defined as a constant equivalent capacitance giving the same charging time as C<sub>oss</sub> when V<sub>DS</sub> increases from 0 to 80% V<sub>DSS</sub>

Table 6. Switching times

Symbol	Parameter	Test conditions	Min.	Typ.	Max.	Unit
$t_{d(on)}$	Turn-on delay time	$V_{DD} = 260 \text{ V}$ , $I_D = 2.2 \text{ A}$ , $R_G = 4.7 \text{ } \Omega$ , $V_{GS} = 10 \text{ V}$ (see Figure 16)	-	11.4	-	ns
$t_r$	Rise time		-	13.6	-	ns
$t_{d(off)}$	Turn-off-delay time		-	23.1	-	ns
$t_f$	Fall time		-	15	-	ns

Table 7. Source drain diode

Symbol	Parameter	Test conditions	Min.	Typ.	Max.	Unit
$I_{SD}$	Source-drain current		-		4.4	A
$I_{SDM}^{(1)}$	Source-drain current (pulsed)		-		17.6	A
$V_{SD}^{(2)}$	Forward on voltage	$I_{SD} = 4.4 \text{ A}$ , $V_{GS} = 0$	-		1.6	V
$t_{rr}$	Reverse recovery time	$I_{SD} = 4.4 \text{ A}$ , $di/dt = 100 \text{ A}/\mu\text{s}$ $V_{DD} = 60 \text{ V}$ (see Figure 18)	-	55		ns
$Q_{rr}$	Reverse recovery charge		-	95		nC
$I_{RRM}$	Reverse recovery current		-	3.5		A
$t_{rr}$	Reverse recovery time	$I_{SD} = 4.4 \text{ A}$ , $di/dt = 100 \text{ A}/\mu\text{s}$ $V_{DD} = 60 \text{ V}$ , $T_J = 150 \text{ }^\circ\text{C}$ (see Figure 18)	-	120		ns
$Q_{rr}$	Reverse recovery charge		-	266		nC
$I_{RRM}$	Reverse recovery current		-	4.5		A

1. Pulse width limited by safe operating area
2. Pulsed: pulse duration = 300  $\mu\text{s}$ , duty cycle 1.5%

Table 8. Gate-source Zener diode

Symbol	Parameter	Test conditions	Min	Typ.	Max.	Unit
$V_{(BR)GSO}$	Gate-source breakdown voltage	$I_{GS} = \pm 1 \text{ mA}$ , $I_D = 0$	30	-	-	V

The built-in back-to-back Zener diodes have specifically been designed to enhance the device's ESD capability. In this respect the Zener voltage is appropriate to achieve an efficient and cost-effective intervention to protect the device's integrity. These integrated Zener diodes thus avoid the usage of external components.

## 2.1 Electrical characteristics (curves)

Figure 2. Safe operating area for DPAK

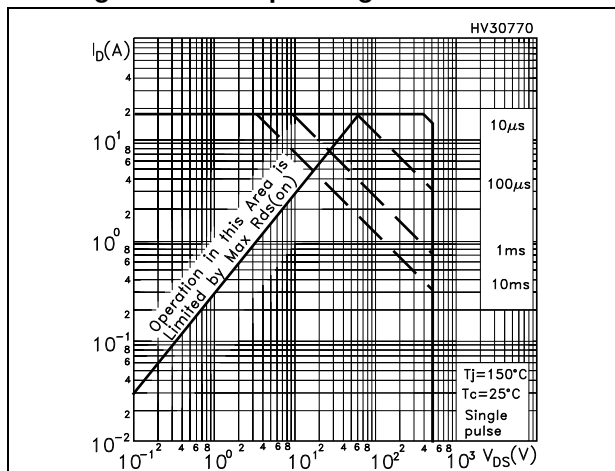

Figure 3. Thermal impedance for DPAK

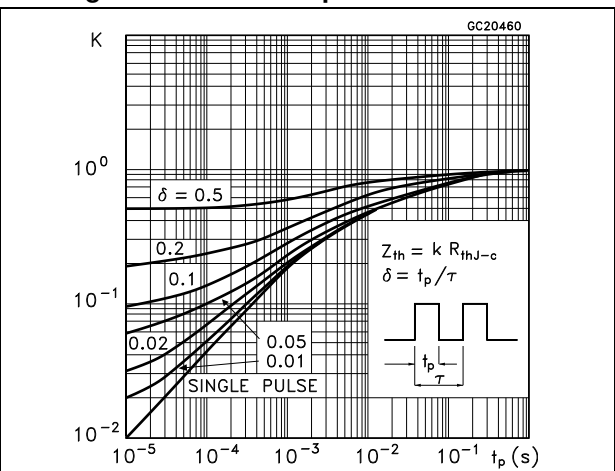

Figure 4. Safe operating area for TO-220FP

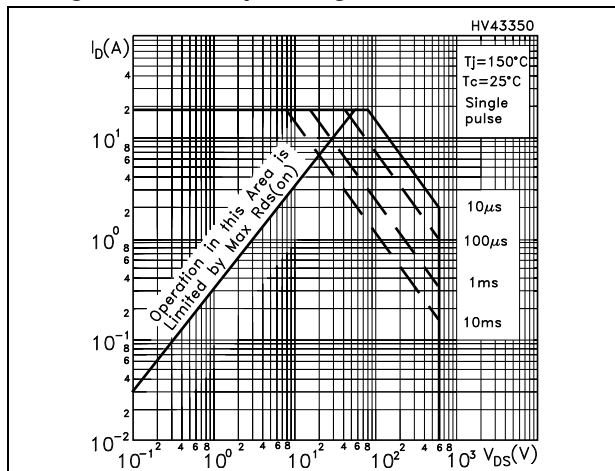

Figure 5. Thermal impedance for TO-220FP

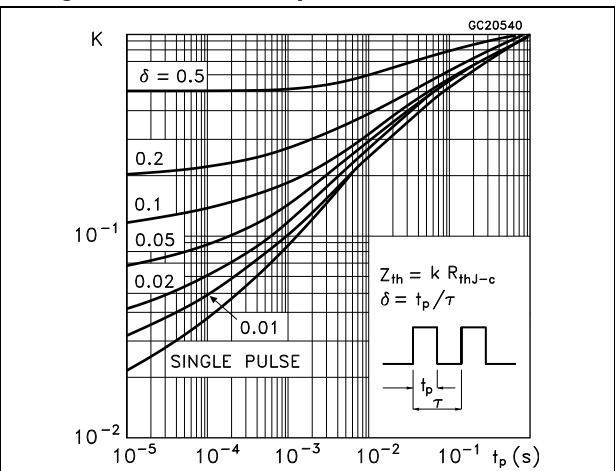

Figure 6. Output characteristics

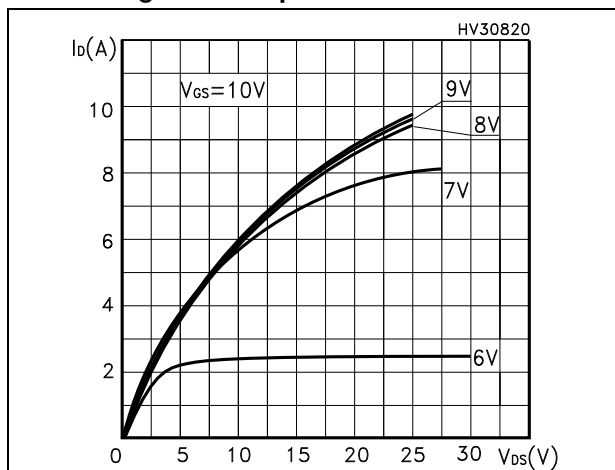

Figure 7. Transfer characteristics

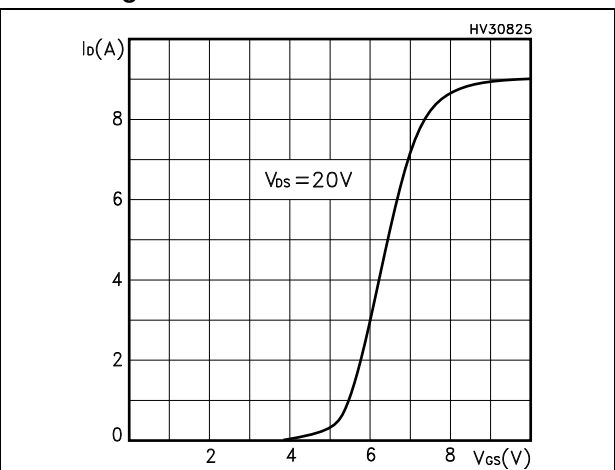

Figure 8. Normalized  $V_{(BR)DSS}$  vs temperature

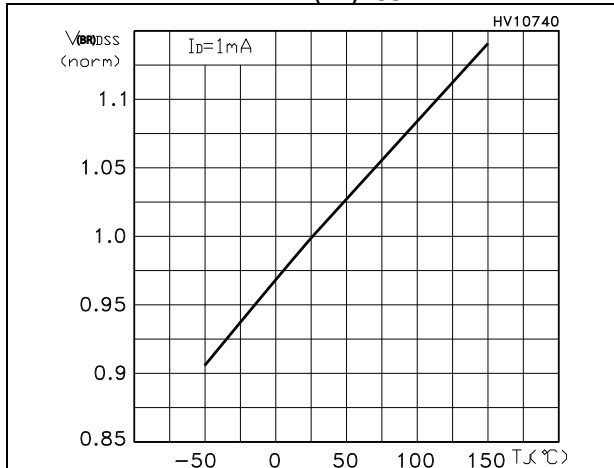

Figure 9. Static drain-source on-resistance

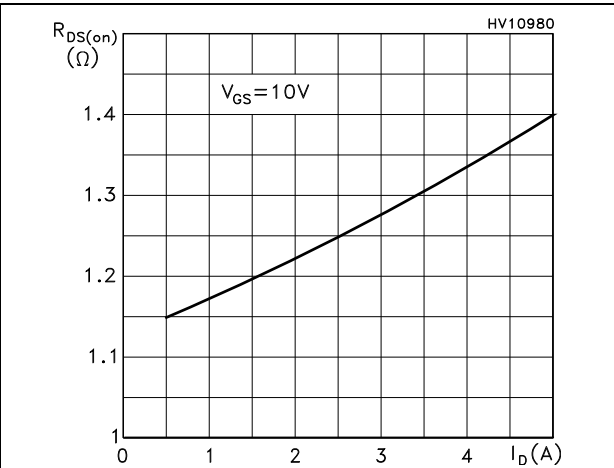

Figure 10. Gate charge vs gate-source voltage

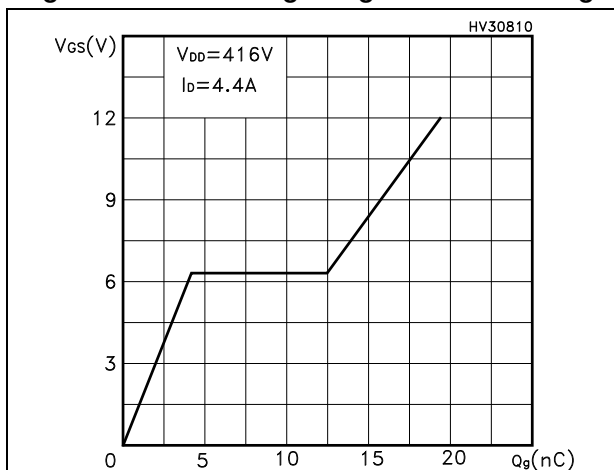

Figure 11. Capacitance variations

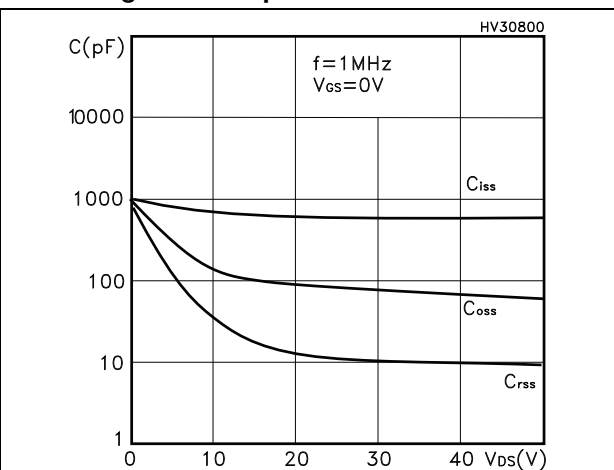

Figure 12. Normalized gate threshold voltage vs temperature

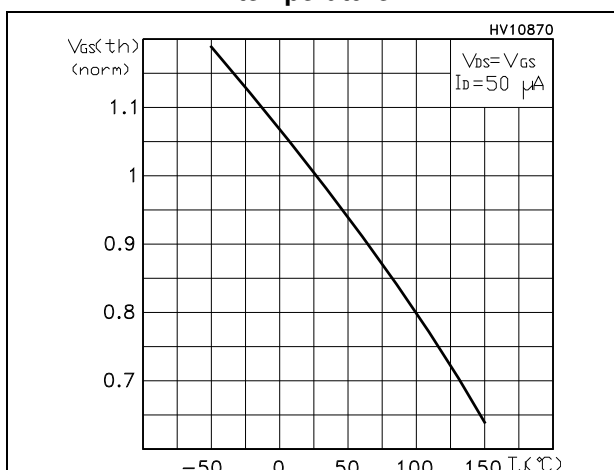

Figure 13. Normalized on-resistance vs temperature

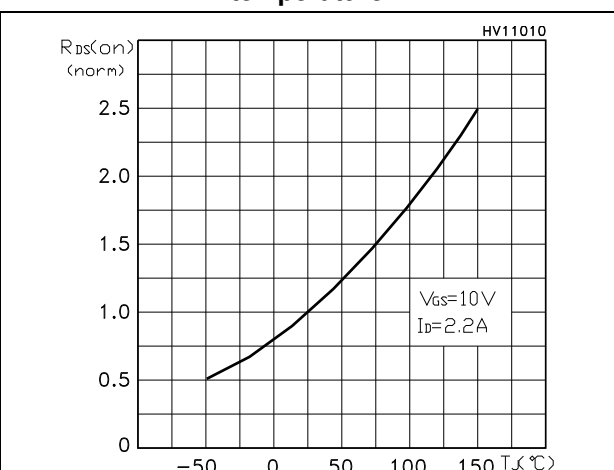

Figure 14. Source-drain diode forward characteristics

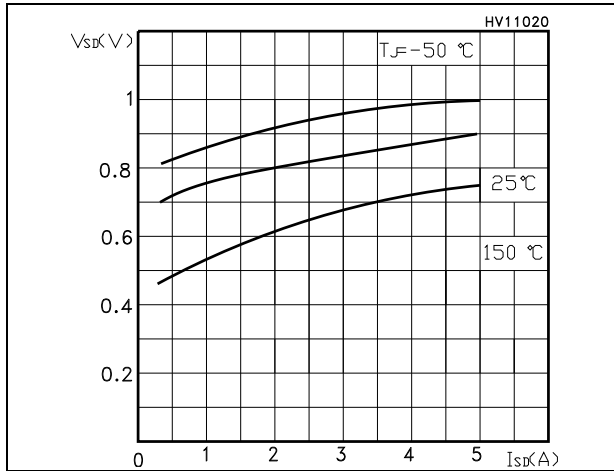
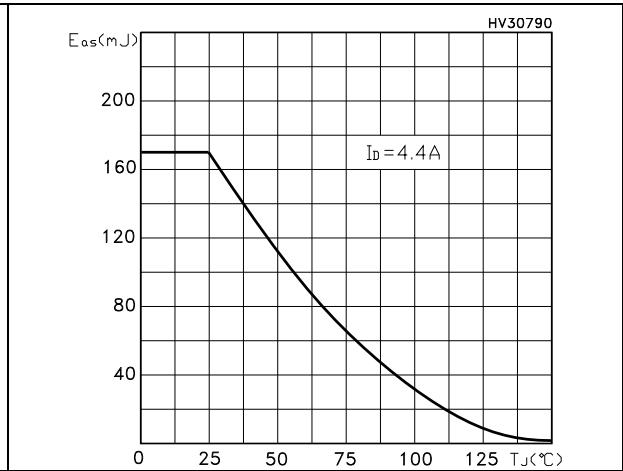

Figure 15. Maximum avalanche energy vs temperature





### 3 Test circuits

Figure 16. Switching times test circuit for resistive load

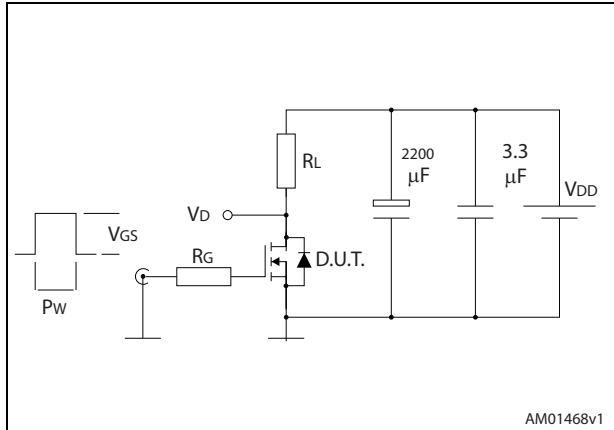

AM01468v1

Figure 17. Gate charge test circuit

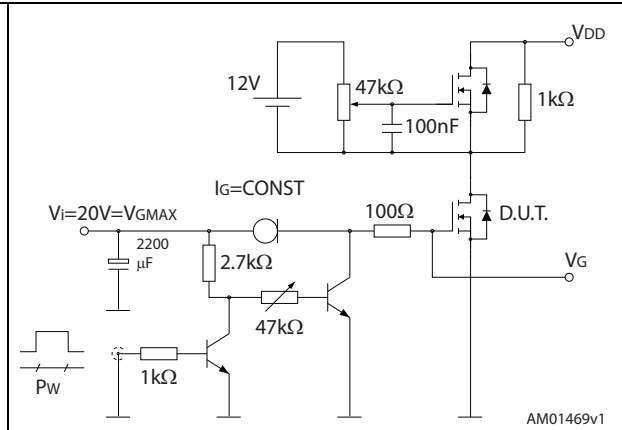

AM01469v1

Figure 18. Test circuit for inductive load switching and diode recovery times

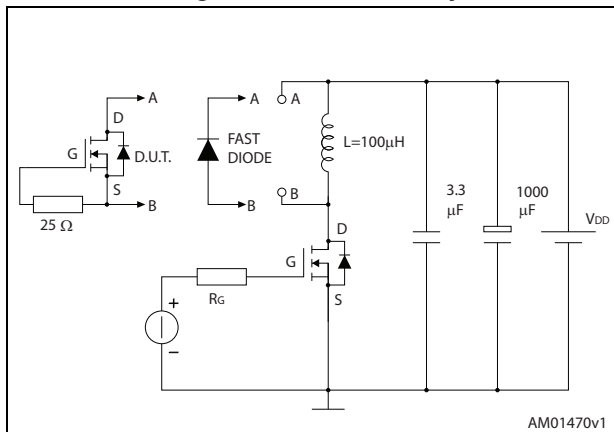

AM01470v1

Figure 19. Unclamped inductive load test circuit

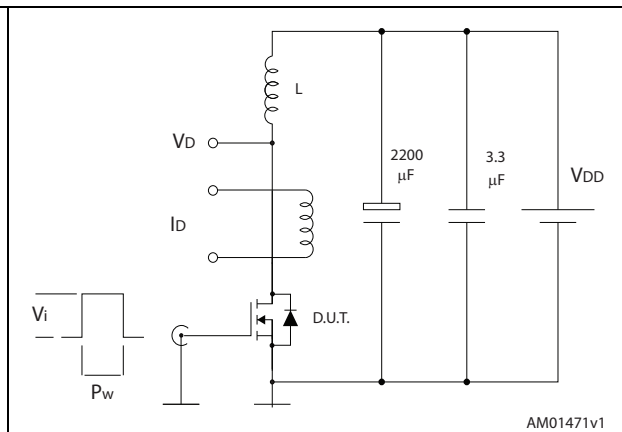

AM01471v1

Figure 20. Unclamped inductive waveform

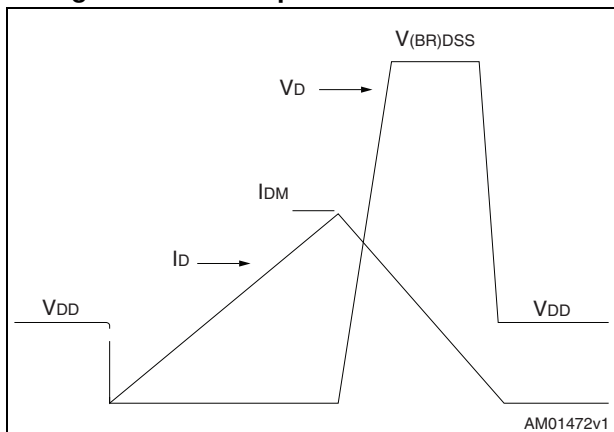

AM01472v1

Figure 21. Switching time waveform

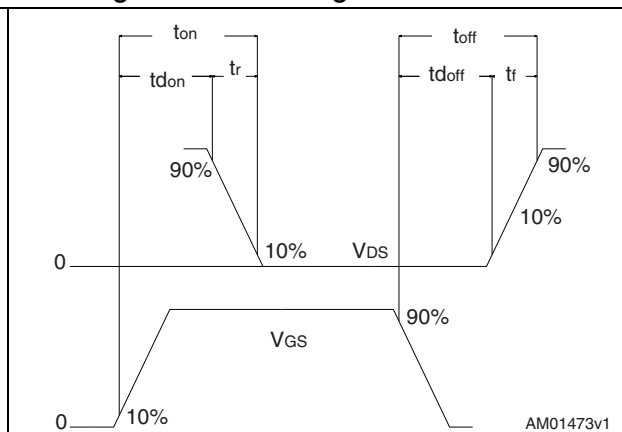

AM01473v1

## 4 Package mechanical data

In order to meet environmental requirements, ST offers these devices in different grades of ECOPACK<sup>®</sup> packages, depending on their level of environmental compliance. ECOPACK<sup>®</sup> specifications, grade definitions and product status are available at: [www.st.com](http://www.st.com). ECOPACK<sup>®</sup> is an ST trademark.

4.1 DPAK, STD5N52U

Figure 22. DPAK (TO-252) type A drawing

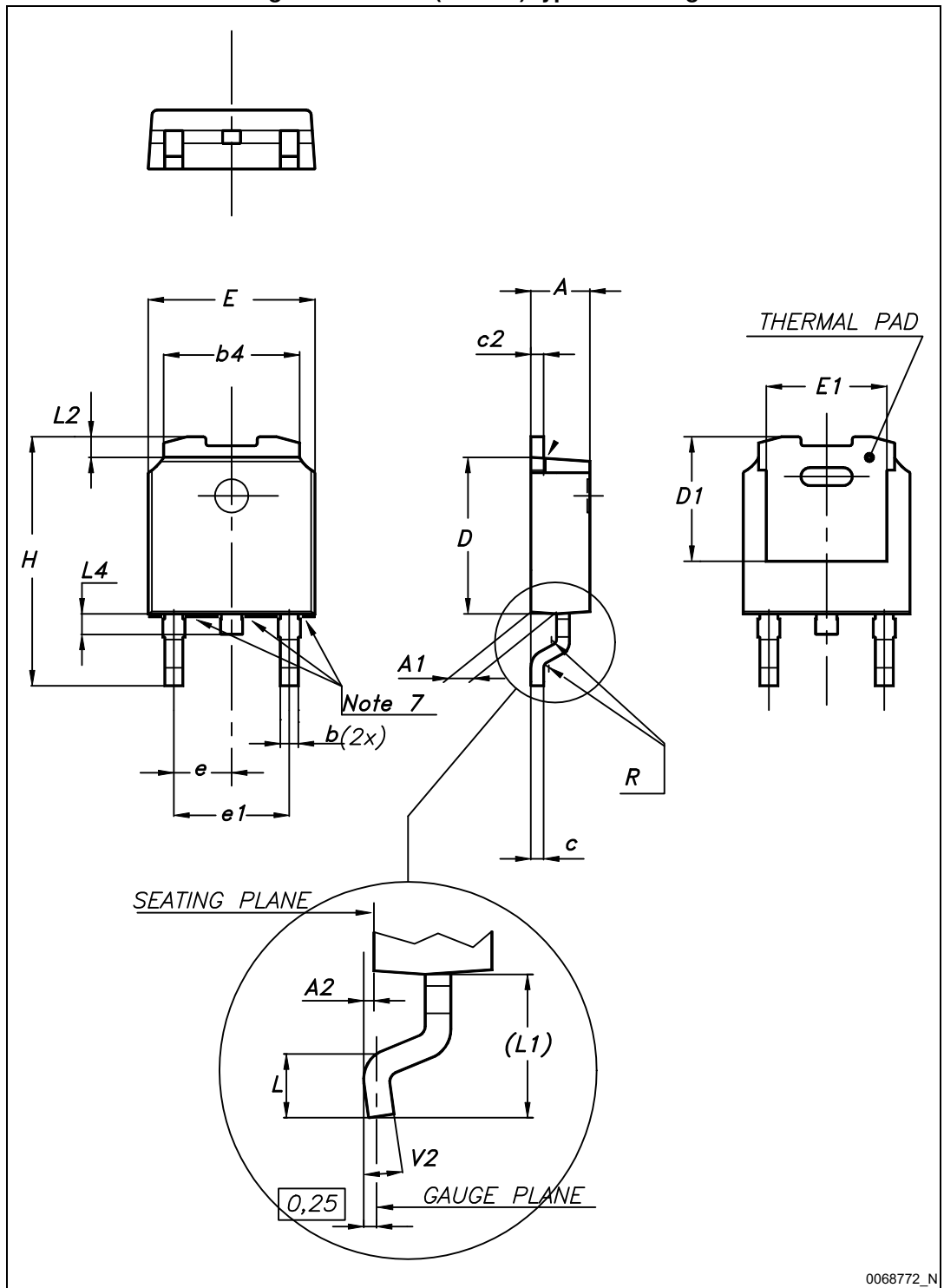
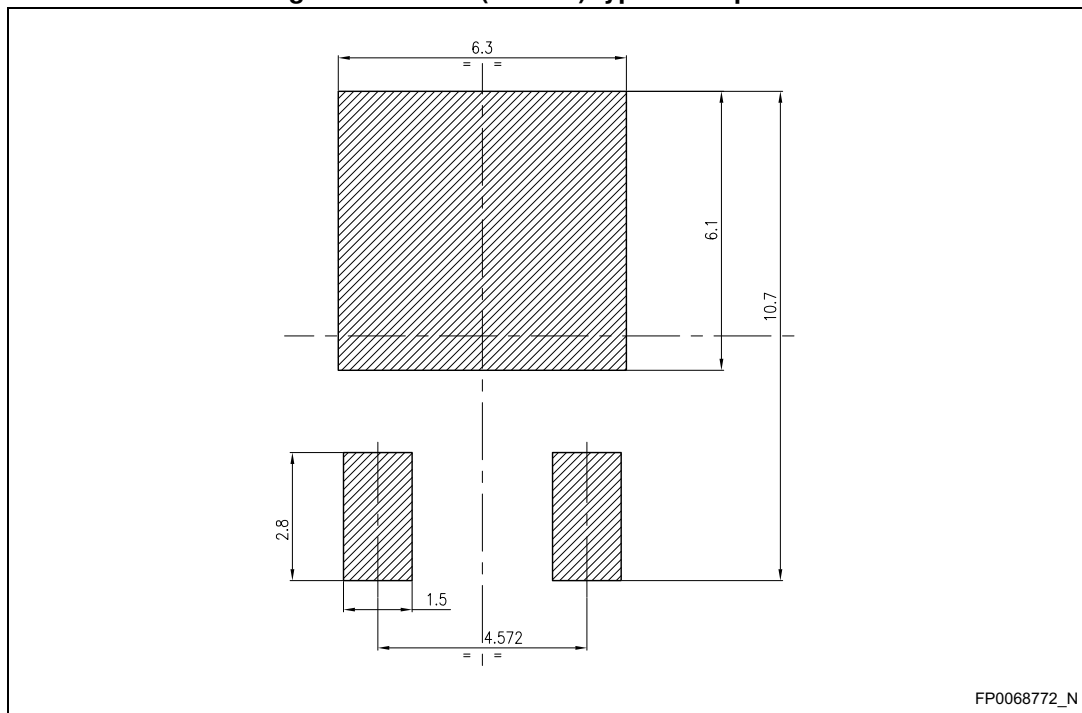

Table 9. DPAK (TO-252) type A mechanical data

Dim.	mm		
	Min.	Typ.	Max.
A	2.20		2.40
A1	0.90		1.10
A2	0.03		0.23
b	0.64		0.90
b4	5.20		5.40
c	0.45		0.60
c2	0.48		0.60
D	6.00		6.20
D1		5.10	
E	6.40		6.60
E1		4.70	
e		2.28	
e1	4.40		4.60
H	9.35		10.10
L	1.00		1.50
(L1)		2.80	
L2		0.80	
L4	0.60		1.00
R		0.20	
V2	0°		8°

Figure 23. DPAK (TO-252) type A footprint (a)



a. All dimensions are in millimeters

### 4.2 TO-220FP, STF5N52U

Figure 24. TO-220FP drawing

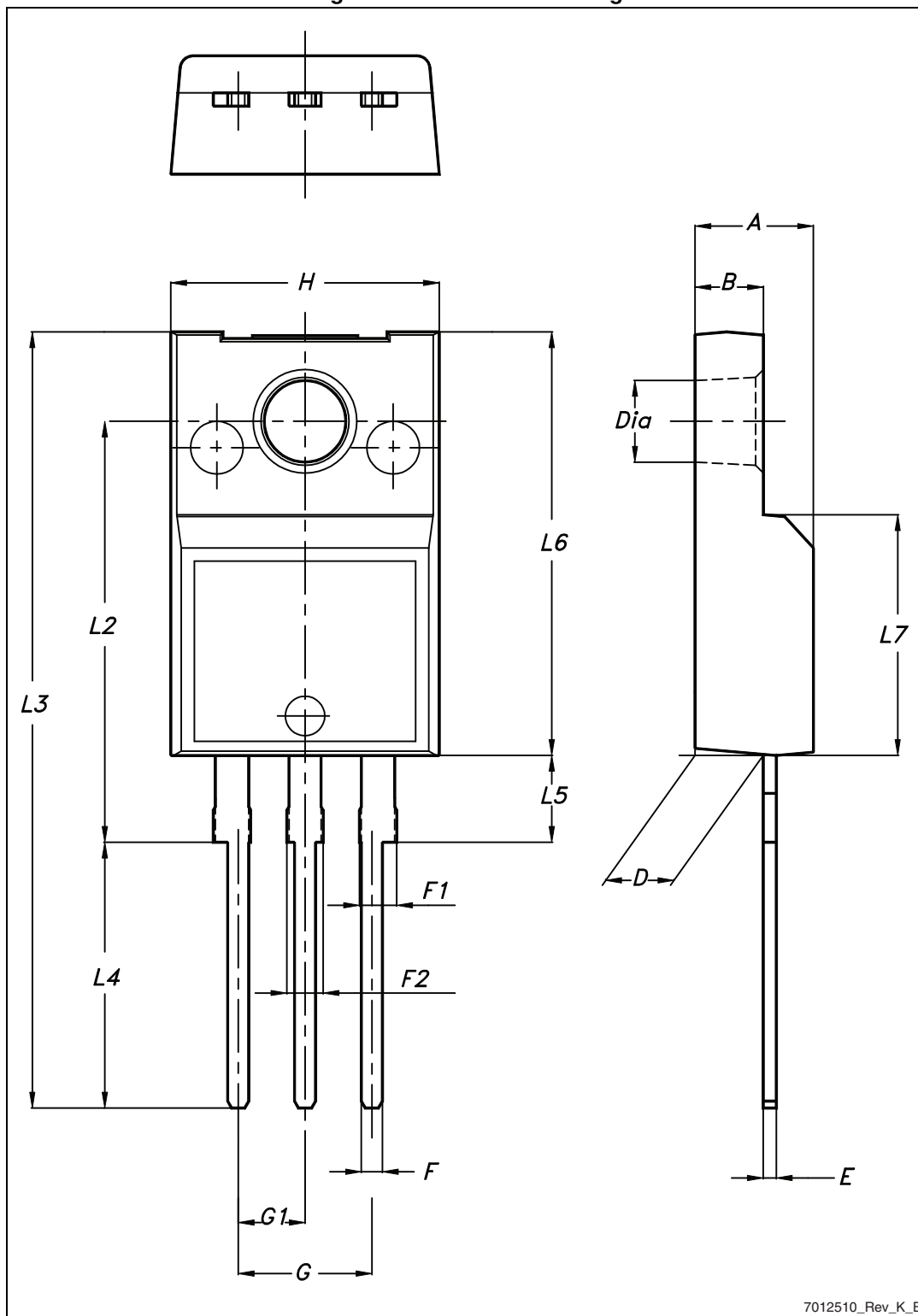

7012510\_Rev\_K\_B

Table 10. TO-220FP mechanical data

Dim.	mm		
	Min.	Typ.	Max.
A	4.4		4.6
B	2.5		2.7
D	2.5		2.75
E	0.45		0.7
F	0.75		1
F1	1.15		1.70
F2	1.15		1.70
G	4.95		5.2
G1	2.4		2.7
H	10		10.4
L2		16	
L3	28.6		30.6
L4	9.8		10.6
L5	2.9		3.6
L6	15.9		16.4
L7	9		9.3
Ø	3		3.2

# 5 Packaging mechanical data

Figure 25. Tape for DPAK (TO-252)

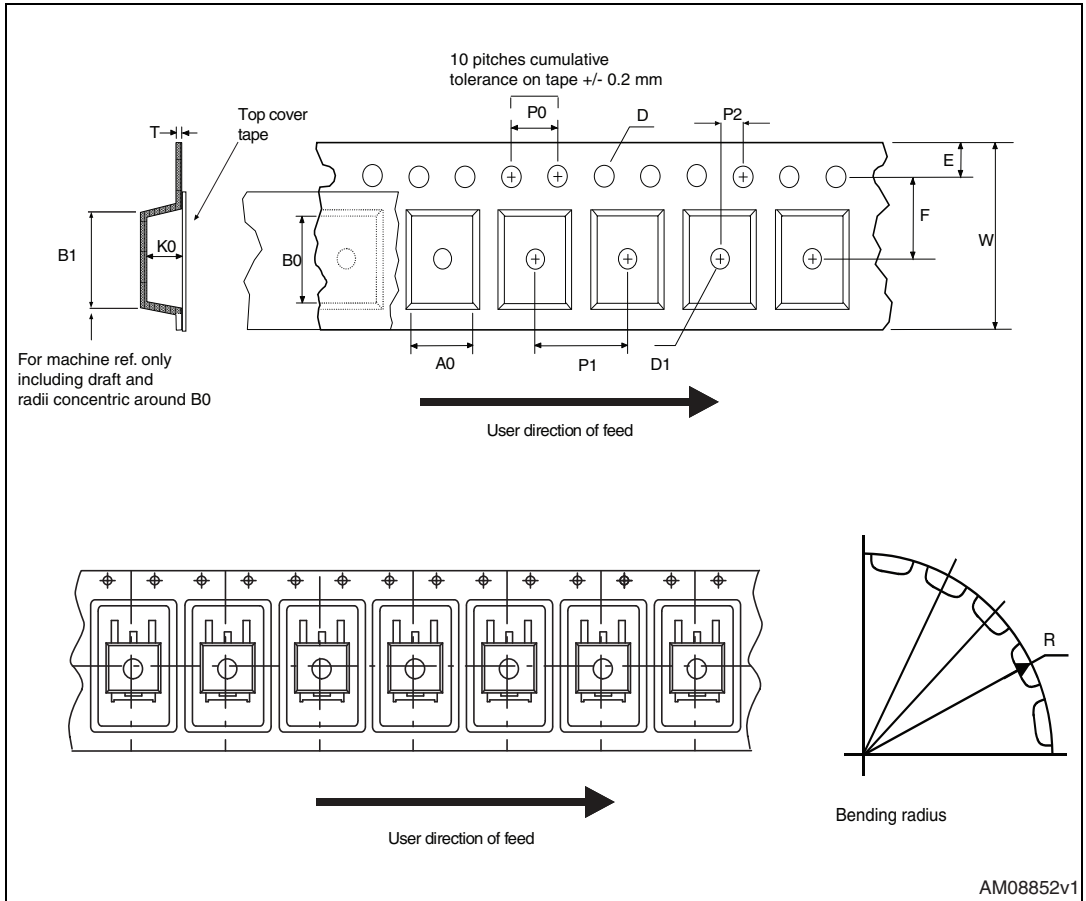



Figure 26. Reel for DPAK (TO-252)

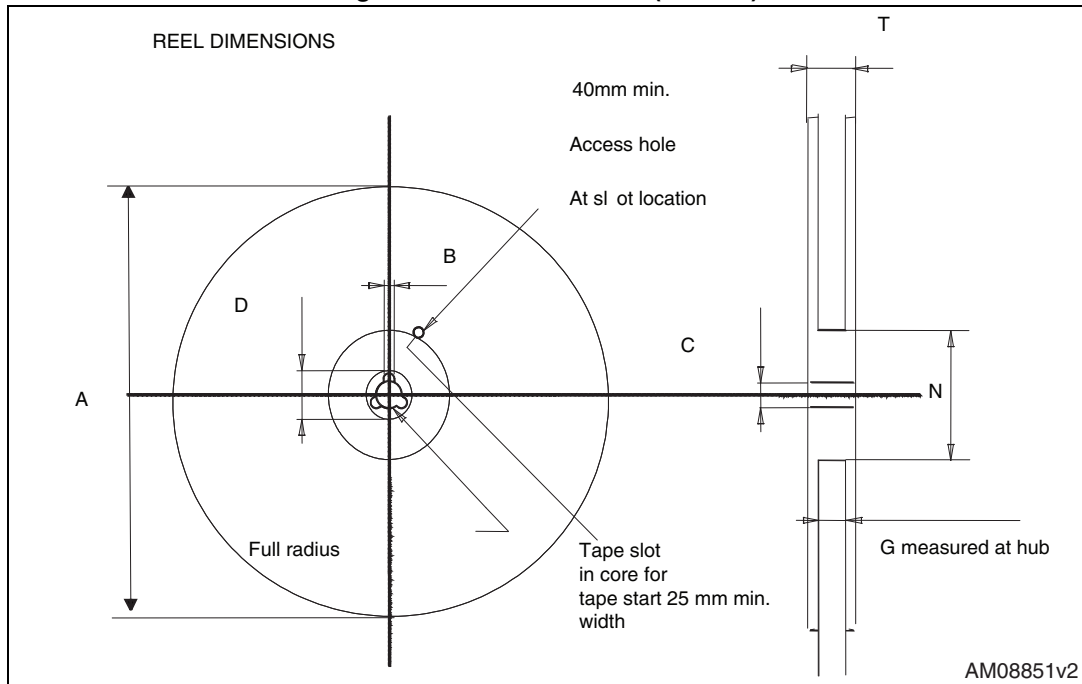

Table 11. DPAK (TO-252) tape and reel mechanical data

Tape			Reel		
Dim.	mm		Dim.	mm	
	Min.	Max.		Min.	Max.
A0	6.8	7	A		330
B0	10.4	10.6	B	1.5	
B1		12.1	C	12.8	13.2
D	1.5	1.6	D	20.2	
D1	1.5		G	16.4	18.4
E	1.65	1.85	N	50	
F	7.4	7.6	T		22.4
K0	2.55	2.75			
P0	3.9	4.1		Base qty.	2500
P1	7.9	8.1		Bulk qty.	2500
P2	1.9	2.1			
R	40				
T	0.25	0.35			
W	15.7	16.3			

## 6 Revision history

Table 12. Document revision history

Date	Revision	Changes
06-May-2009	1	First release.
28-Sep-2011	2	<ul style="list-style-type: none"><li>– Inserted new device in I<sup>2</sup>PAK.</li><li>– Updated tables 1, 2 and 3 with the new package.</li><li>– Updated <a href="#">Section 4: Package mechanical data</a> with the new package and <a href="#">Section 5: Packaging mechanical data</a>.</li><li>– Minor text changes.</li></ul>
24-Apr-2014	3	<ul style="list-style-type: none"><li>– Updated <a href="#">Section 4.1: DPAK, STD5N52U</a></li><li>– Modified: Q<sub>rr</sub> unit in <a href="#">Table 7</a></li><li>– Modified: <a href="#">Figure 8</a> and <a href="#">11</a></li><li>– The part number STI5N52U has been moved to a separate datasheet</li></ul>

**Please Read Carefully:**

Information in this document is provided solely in connection with ST products. STMicroelectronics NV and its subsidiaries ("ST") reserve the right to make changes, corrections, modifications or improvements, to this document, and the products and services described herein at any time, without notice.

All ST products are sold pursuant to ST's terms and conditions of sale.

Purchasers are solely responsible for the choice, selection and use of the ST products and services described herein, and ST assumes no liability whatsoever relating to the choice, selection or use of the ST products and services described herein.

No license, express or implied, by estoppel or otherwise, to any intellectual property rights is granted under this document. If any part of this document refers to any third party products or services it shall not be deemed a license grant by ST for the use of such third party products or services, or any intellectual property contained therein or considered as a warranty covering the use in any manner whatsoever of such third party products or services or any intellectual property contained therein.

**UNLESS OTHERWISE SET FORTH IN ST'S TERMS AND CONDITIONS OF SALE ST DISCLAIMS ANY EXPRESS OR IMPLIED WARRANTY WITH RESPECT TO THE USE AND/OR SALE OF ST PRODUCTS INCLUDING WITHOUT LIMITATION IMPLIED WARRANTIES OF MERCHANTABILITY, FITNESS FOR A PARTICULAR PURPOSE (AND THEIR EQUIVALENTS UNDER THE LAWS OF ANY JURISDICTION), OR INFRINGEMENT OF ANY PATENT, COPYRIGHT OR OTHER INTELLECTUAL PROPERTY RIGHT.**

**ST PRODUCTS ARE NOT DESIGNED OR AUTHORIZED FOR USE IN: (A) SAFETY CRITICAL APPLICATIONS SUCH AS LIFE SUPPORTING, ACTIVE IMPLANTED DEVICES OR SYSTEMS WITH PRODUCT FUNCTIONAL SAFETY REQUIREMENTS; (B) AERONAUTIC APPLICATIONS; (C) AUTOMOTIVE APPLICATIONS OR ENVIRONMENTS, AND/OR (D) AEROSPACE APPLICATIONS OR ENVIRONMENTS. WHERE ST PRODUCTS ARE NOT DESIGNED FOR SUCH USE, THE PURCHASER SHALL USE PRODUCTS AT PURCHASER'S SOLE RISK, EVEN IF ST HAS BEEN INFORMED IN WRITING OF SUCH USAGE, UNLESS A PRODUCT IS EXPRESSLY DESIGNATED BY ST AS BEING INTENDED FOR "AUTOMOTIVE, AUTOMOTIVE SAFETY OR MEDICAL" INDUSTRY DOMAINS ACCORDING TO ST PRODUCT DESIGN SPECIFICATIONS. PRODUCTS FORMALLY ESCC, QML OR JAN QUALIFIED ARE DEEMED SUITABLE FOR USE IN AEROSPACE BY THE CORRESPONDING GOVERNMENTAL AGENCY.**

Resale of ST products with provisions different from the statements and/or technical features set forth in this document shall immediately void any warranty granted by ST for the ST product or service described herein and shall not create or extend in any manner whatsoever, any liability of ST.

ST and the ST logo are trademarks or registered trademarks of ST in various countries.

Information in this document supersedes and replaces all information previously supplied.

The ST logo is a registered trademark of STMicroelectronics. All other names are the property of their respective owners.

© 2014 STMicroelectronics - All rights reserved

STMicroelectronics group of companies

Australia - Belgium - Brazil - Canada - China - Czech Republic - Finland - France - Germany - Hong Kong - India - Israel - Italy - Japan - Malaysia - Malta - Morocco - Philippines - Singapore - Spain - Sweden - Switzerland - United Kingdom - United States of America

[www.st.com](http://www.st.com)

