



STD70N02L STD70N02L-1

N-channel 25V - 0.0068Ω - 60A - DPAK - IPAK
STripFET™ III Power MOSFET

Features

Type	V _{DSS}	R _{DS(on)}	I _D
STD70N02L	25V	<0.008Ω	60A
STD70N02L-1	25V	<0.008Ω	60A

- R_{DS(ON)} * Qg industry's benchmark
- Conduction losses reduced
- Switching losses reduced
- Low threshold device

Application

- Switching applications

Description

This series of products utilizes the latest advanced design rules of ST's proprietary STripFET™ technology. This is suitable for the most demanding DC-DC converter application where high efficiency is to be achieved.

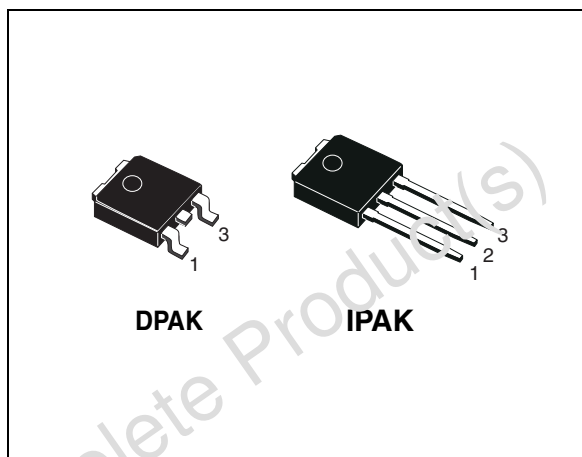

Figure 1. Internal schematic diagram

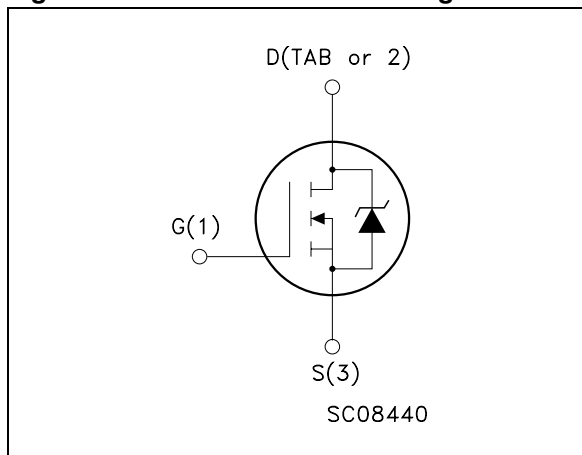

Table 1. Device summary

Order codes	Marking	Package	Packaging
STD70N02L-1	D70N02L	IPAK	Tube
STD70N02L	D70N02L	DPAK	Tape & reel

Contents

1	Electrical ratings	3
2	Electrical characteristics	4
2.1	Electrical characteristics (curves)	6
3	Test circuits	11
4	Package mechanical data	12
5	Package mechanical data	15
6	Revision history	16

Obsolete Product(s) - Obsolete Product(s)

1 Electrical ratings

Table 2. Absolute maximum ratings

Symbol	Parameter	Value	Unit
$V_{\text{spike}}^{(1)}$	Drain-source voltage rating	30	V
V_{DS}	Drain-source voltage ($V_{\text{GS}} = 0$)	25	V
V_{DGR}	Drain-gate voltage ($R_{\text{GS}} = 20\text{k}\Omega$)	25	V
V_{GS}	Gate-source voltage	± 20	V
$I_{\text{D}}^{(2)}$	Drain current (continuous) at $T_{\text{C}} = 25^{\circ}\text{C}$	60	A
I_{D}	Drain current (continuous) at $T_{\text{C}} = 100^{\circ}\text{C}$	42	A
$I_{\text{DM}}^{(3)}$	Drain current (pulsed)	240	A
P_{TOT}	Total dissipation at $T_{\text{C}} = 25^{\circ}\text{C}$	60	W
	Derating factor	0.4	W/ $^{\circ}\text{C}$
$E_{\text{AS}}^{(4)}$	Single pulse avalanche energy	280	mJ
T_{j} T_{stg}	Operating junction temperature Storage temperature	-55 to 175	$^{\circ}\text{C}$

1. Guaranteed when external $R_{\text{g}}=4.7\Omega$ and $T_{\text{f}}<T_{\text{fmax}}$
2. Value limited by wire bonding
3. Pulse width limited by safe operating area
4. Starting $T_{\text{j}}=25^{\circ}\text{C}$, $I_{\text{d}} = 30\text{A}$, $V_{\text{DD}} = 15\text{V}$

Table 3. Thermal data

Symbol	Parameter	Value	Unit
$R_{\text{thj-case}}$	Thermal resistance junction-case Max	2.5	$^{\circ}\text{C}/\text{W}$
$R_{\text{thj-amb}}$	Thermal resistance junction-amb Max	100	$^{\circ}\text{C}/\text{W}$
T_{l}	Maximum lead temperature for soldering purpose	275	$^{\circ}\text{C}$

2 Electrical characteristics

(T_{case} =25°C unless otherwise specified)

Table 4. On /off states

Symbol	Parameter	Test conditions	Min.	Typ.	Max.	Unit
V _{(BR)DSS}	Drain-source breakdown voltage	I _D = 25mA, V _{GS} = 0	25			V
I _{DSS}	Zero gate voltage drain current (V _{GS} = 0)	V _{DS} = 20V, V _{DS} = 20V, T _c = 125°C			1 10	μA μA
I _{GSS}	Gate body leakage current (V _{DS} = 0)	V _{GS} = ±20V			±100	nA
V _{GS(th)}	Gate threshold voltage	V _{DS} = V _{GS} , I _D = 250μA	1	1.8		V
R _{DS(on)}	Static drain-source on resistance	V _{GS} = 10V, I _D = 30A V _{GS} = 5V, I _D = 15A		0.0068 0.090	0.008 0.014	Ω Ω

Table 5. Dynamic

Symbol	Parameter	Test conditions	Min.	Typ.	Max.	Unit
g _{fs} (1)	Forward transconductance	V _{DS} =15V, I _D = 30A		27		S
C _{iss} C _{oss} C _{rss}	Input capacitance Output capacitance Reverse transfer capacitance	V _{DS} =16V, f=1MHz, V _{GS} =0		1400 400 55		pF pF pF
Q _g Q _{gs} C _{gd}	Total gate charge Gate-source charge Gate-drain charge	V _{DD} =10V, I _D = 60A V _{GS} =10V (see Figure 8)		24 5 3.4	32	nC nC nC
R _G	Gate input resistance	f=1MHz Gate DC Bias =0 test signal level =20mV open drain	0.5	1.5	3	Ω
Q _{OSS} (2)	Output charge	V _{DS} =16V, V _{GS} =0V		9.4		nC

1. Pulsed: pulse duration = 300μs, duty cycle 1.5%

2. Q_{OSS} = C_{OSS} * D Vin, C_{OSS} = C_{gd} + C_{gd}. (see [Appendix A](#))

Table 6. Switching times

Symbol	Parameter	Test conditions	Min.	Typ.	Max	Unit
$t_{d(on)}$	Turn-on delay time	$V_{DD}=10V, I_D=30A,$ $R_G=4.7\Omega, V_{GS}=10V$ (see Figure 18)		10		ns
t_r	Rise time			130		ns
$t_{d(off)}$	Turn-off delay time			27		ns
t_f	Fall time			16	21.6	ns

Table 7. Source drain diode

Symbol	Parameter	Test conditions	Min.	Typ.	Max.	Unit
I_{SD}	Source-drain current				50	A
I_{SDM}	Source-drain current (pulsed)				200	A
$V_{SD}^{(1)}$	Forward on voltage	$I_{SD}=30A, V_{GS}=0$			1.3	V
t_{rr}	Reverse recovery time	$I_{SD}=60A, di/dt = 100A/\mu s,$ $V_{DD}=20V, T_j=150^\circ C$ (see Figure 21)		36		ns
Q_{rr}	Reverse recovery charge			36		nC
I_{RRM}	Reverse recovery current			2		A

1. Pulsed: pulse duration = 300 μs , duty cycle 1.5%

2.1 Electrical characteristics (curves)

Figure 2. Safe operating area

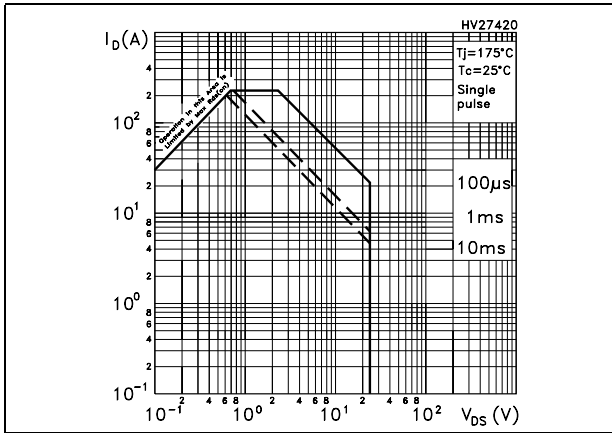

Figure 3. Thermal impedance

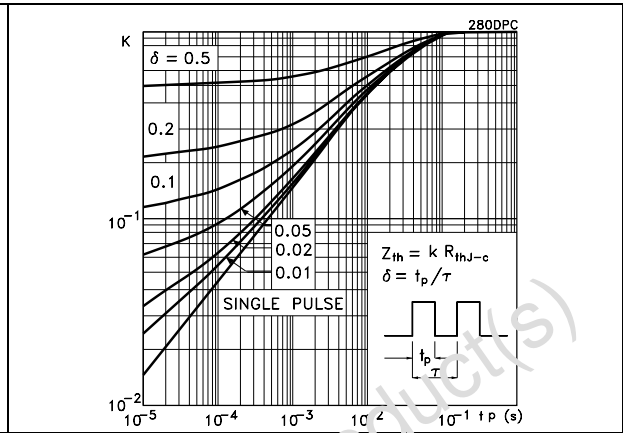

Figure 4. Output characteristics

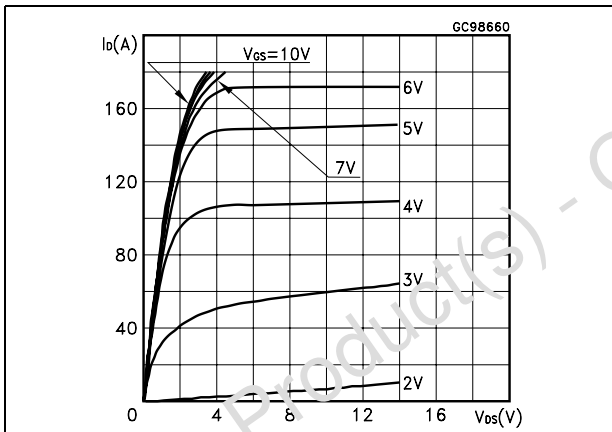

Figure 5. Transfer characteristics

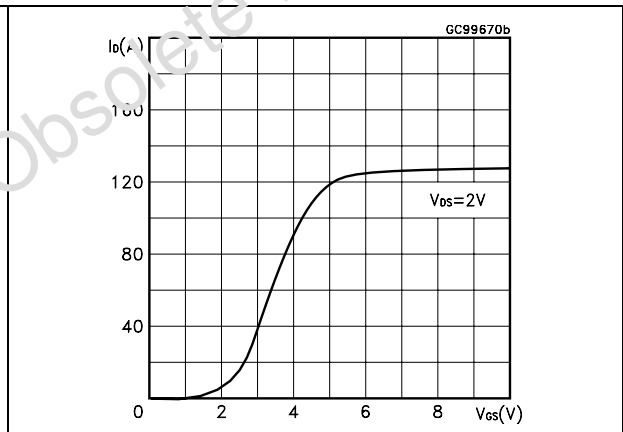

Figure 6. Transconductance

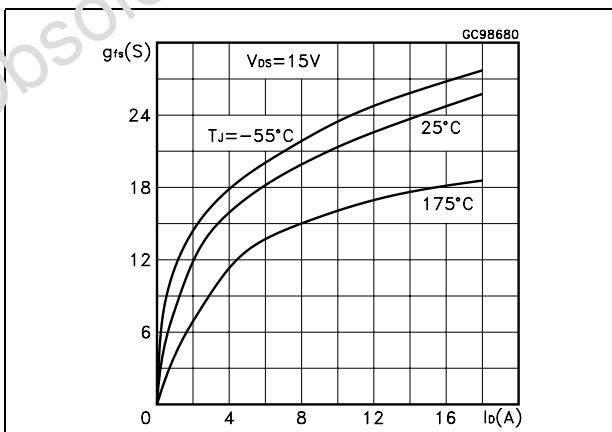

Figure 7. Static drain-source on resistance

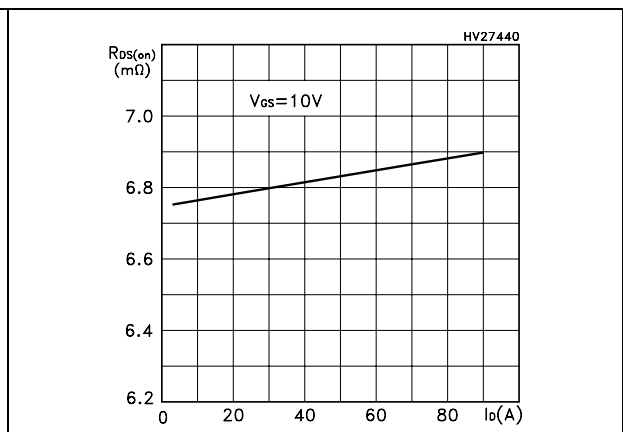

Figure 8. Gate charge vs gate-source voltage Figure 9. Capacitance variations

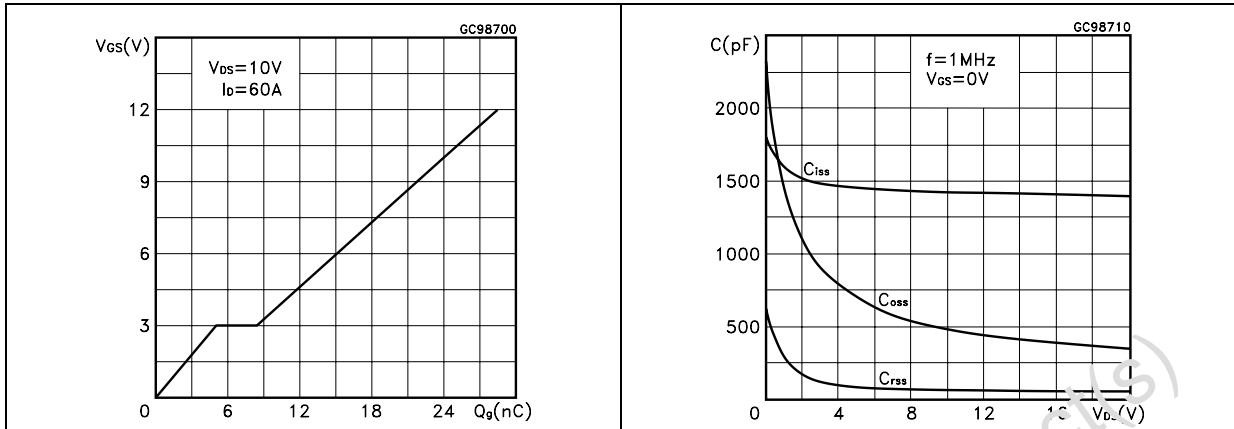

Figure 10. Normalized gate threshold voltage vs temperature Figure 11. Normalized on resistance vs temperature

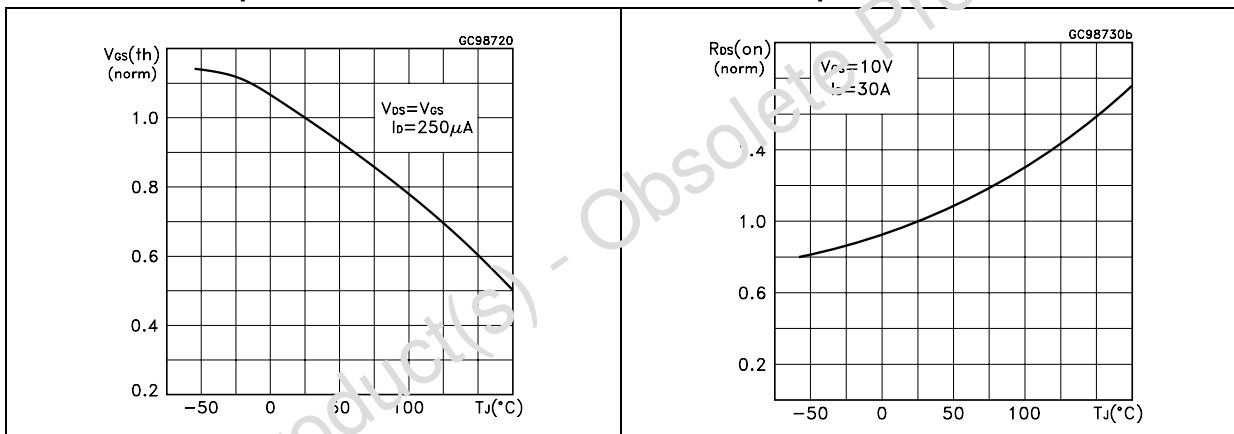

Figure 12. Source-drain diode forward characteristics Figure 13. Normalized $B_{V_{DS}}$ vs temperature

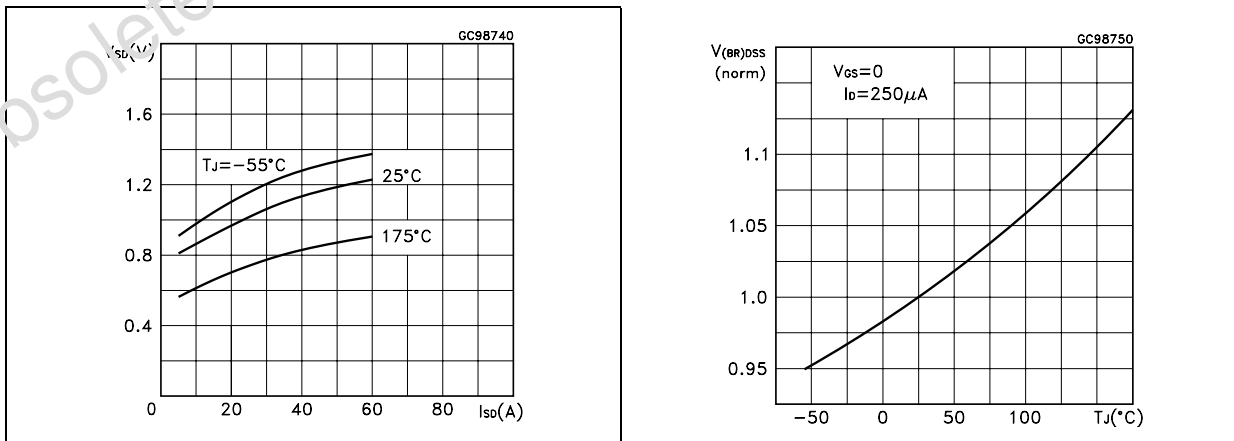
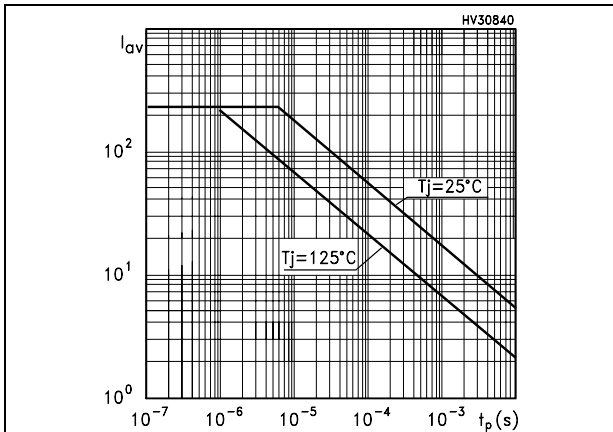

Figure 14. Allowable I_{AV} vs time in avalanche



The previous curve gives the single pulse safe operating area for unclamped inductive loads, under the following conditions:

$$P_{D(AVE)} = 0.5 \cdot (1.3 \cdot B_{VDSS} \cdot I_{AV})$$

$$E_{AS(AR)} = P_{D(AVE)} \cdot t_{AV}$$

Where:

I_{AV} is the allowable current in avalanche

$P_{D(AVE)}$ is the average power dissipation in avalanche (single pulse)

t_{AV} is the time in avalanche

Appendix A Buck convert

Figure 15. Synchronous buck converter

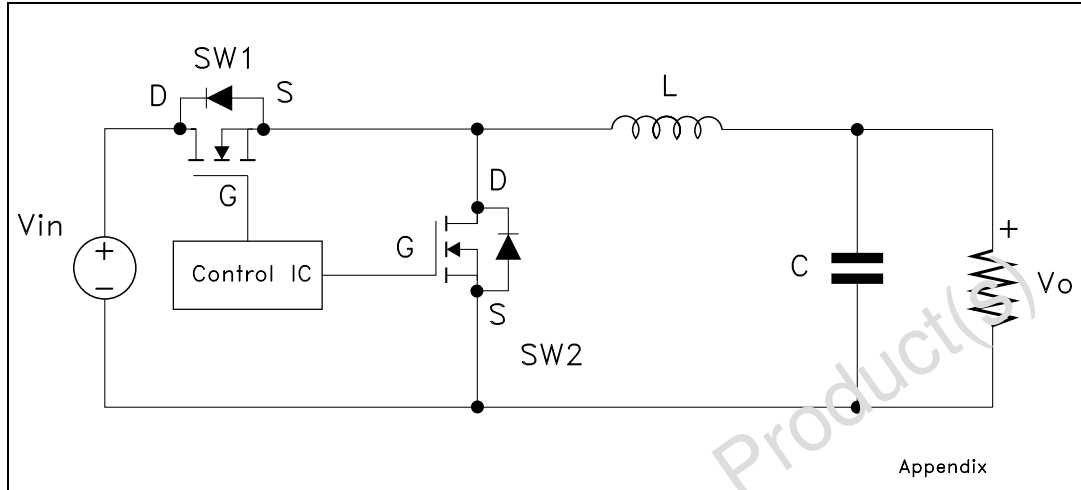

The power losses associated with the FETs in a Synchronous Buck converter can be estimated using the equations shown in the table below. The formulas give a good approximation, for the sake of performance comparison, of how different pairs of devices affect the converter efficiency. However a very important parameter, the working temperature, is not considered. The real device behavior is really dependent on how the heat generated inside the devices is removed to allow for a safer working junction temperature.

The low side (SW2) device requires:

Very low $R_{DS(on)}$ to reduce conduction losses

Small Q_{gls} to reduce the gate charge losses

Small C_{oss} to reduce losses due to output capacitance

Small Q_{rr} to reduce losses on SW1 during its turn-on

The C_{gd}/C_{gs} ratio lower than V_{th}/V_{gg} ratio especially with low drain to source voltage to avoid the cross conduction phenomenon.

The high side (SW1) device requires:

Small R_G and L_G to allow higher gate current peak and to limit the voltage feedback on the gate

Small Q_g to have a faster commutation and to reduce gate charge losses

Low $R_{DS(on)}$ to reduce the conduction losses

Table 8. Power losses

		High side switch (SW1)	Low side switch (SW2)
P _{conduction}		$R_{DS(on)} \cdot I_L^2 \cdot \delta$	$R_{DS(on)} \cdot I_L^2 \cdot (1 - \delta)$
P _{switching}		$V_{in} \cdot (Q_{gsth(SW1)} + Q_{gd(SW1)}) \cdot f \cdot \frac{I_L}{I_g}$	Zero voltage switching
P _{diode}	recovery	Not applicable	$^1V_{in} \cdot Q_{rr(SW2)} \cdot f$
	conduction	Not applicable	$V_{f(SW2)} \cdot I_L \cdot t_{deadtime} \cdot f$
P _{gate(Qg)}		$Q_{g(SW1)} \cdot V_{gg} \cdot f$	$Q_{gls(SV/2)} \cdot V_{gg} \cdot f$
P _{Qoss}		$\frac{V_{in} \cdot Q_{oss(SW1)} \cdot f}{2}$	$\frac{V_{in} \cdot Q_{oss(SW2)} \cdot f}{2}$

Table 9. Power losses parameters

Paramter	Meaning
d	Duty-cycle
Q _{gsth}	Root threshold gate charge
Q _{gls}	Third quadrant gate charge
P _{conduction}	On state losses
P _{switching}	On-off transition losses
P _{diode}	Conduction and reverse recovery diode losses
P _{gate}	Gate driver losses
P _{Qoss}	Output capacitance losses

3 Test circuits

Figure 16. Switching times test circuit for resistive load

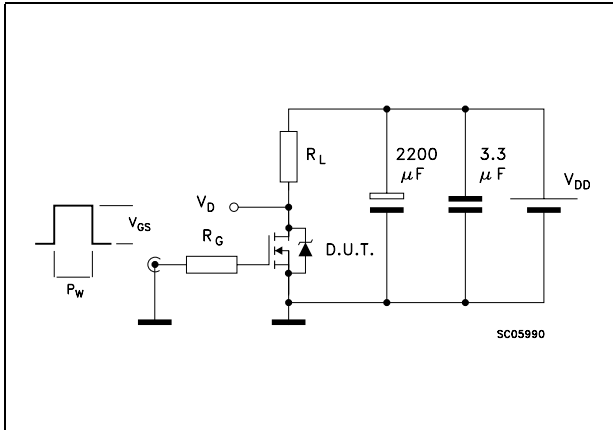

Figure 17. Gate charge test circuit

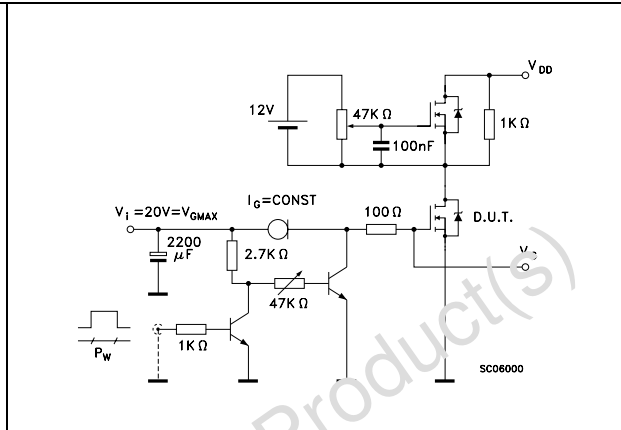

Figure 18. Test circuit for inductive load switching and diode recovery times

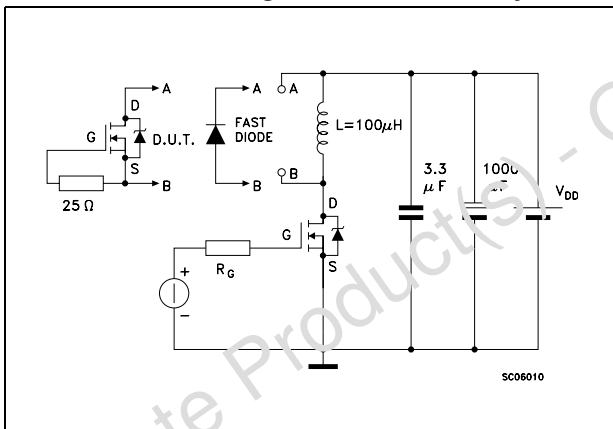

Figure 19. Unclamped inductive load test circuit

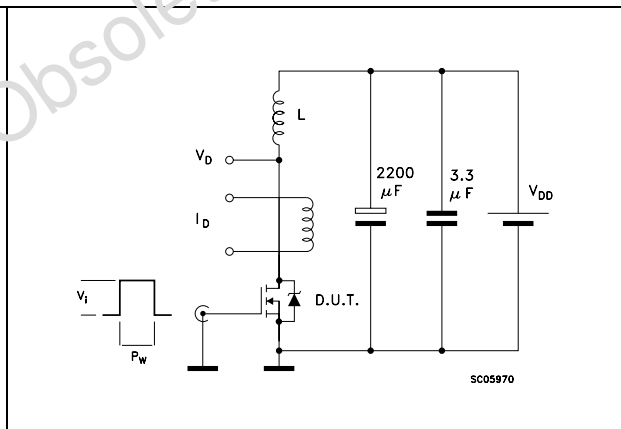

Figure 20. Unclamped inductive waveform

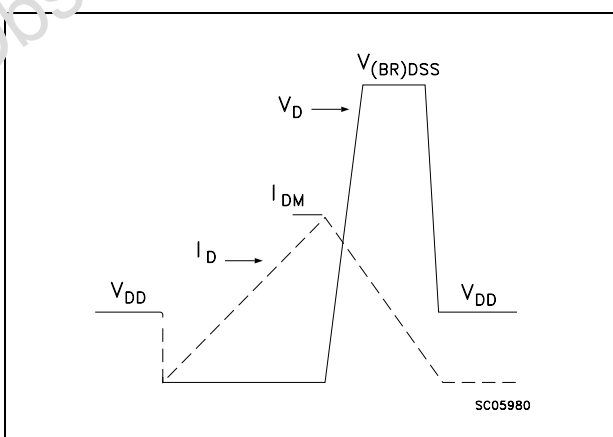
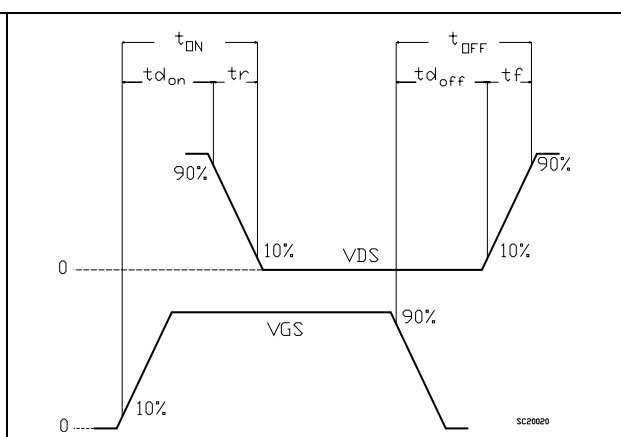

Figure 21. Switching time waveform



4 Package mechanical data

In order to meet environmental requirements, ST offers these devices in ECOPACK® packages. These packages have a Lead-free second level interconnect . The category of second level interconnect is marked on the package and on the inner box label, in compliance with JEDEC Standard JESD97. The maximum ratings related to soldering conditions are also marked on the inner box label. ECOPACK is an ST trademark. ECOPACK specifications are available at : www.st.com

Obsolete Product(s) - Obsolete Product(s)

TO-251 (IPAK) MECHANICAL DATA

DIM.	mm			inch		
	MIN.	TYP.	MAX.	MIN.	TYP.	MAX.
A	2.2		2.4	0.086		0.094
A1	0.9		1.1	0.035		0.043
A3	0.7		1.3	0.027		0.051
B	0.64		0.9	0.025		0.031
B2	5.2		5.4	0.204		0.212
B3			0.85			0.033
B5		0.3			0.012	
B6			0.95			0.037
C	0.45		0.6	0.017		0.023
C2	0.48		0.6	0.019		0.023
D	6		6.2	0.236		0.244
E	6.4		6.6	0.252		0.260
G	4.4		4.6	0.173		0.181
H	15.9		16.3	0.626		0.641
L	9		9.7	0.354		0.370
L1	0.8		1.2	0.031		0.047
L2		0.8	1		0.031	0.039

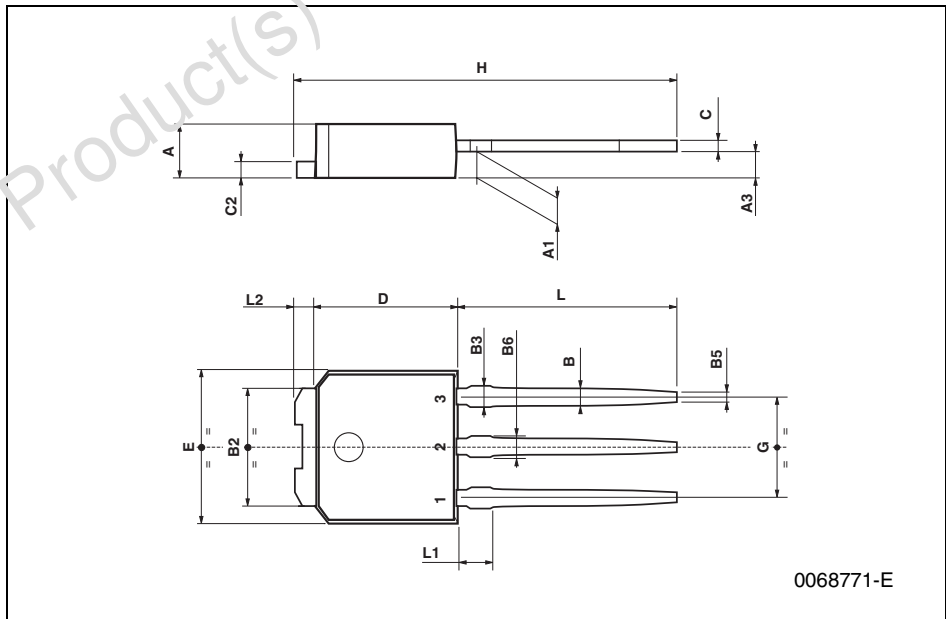

DPAK MECHANICAL DATA

DIM.	mm.			inch		
	MIN.	TYP.	MAX.	MIN.	TYP.	MAX.
A	2.2		2.4	0.086		0.094
A1	0.9		1.1	0.035		0.043
A2	0.03		0.23	0.001		0.009
B	0.64		0.9	0.025		0.035
b4	5.2		5.4	0.204		0.212
C	0.45		0.6	0.017		0.023
C2	0.48		0.6	0.019		0.023
D	6		6.2	0.236		0.244
D1		5.1			0.201	
E	6.4		6.6	0.252		0.260
E1		4.7			0.185	
e		2.28			0.090	
e1	4.4		4.6	0.173		0.181
H	9.35		10.1	0.368		0.397
L	1			0.039		
(L1)		2.8			0.110	
L2		0.8			0.031	
L4	0.6		1	0.023		0.039
R		0.2			0.008	
V2	0°		8°	0°		8°

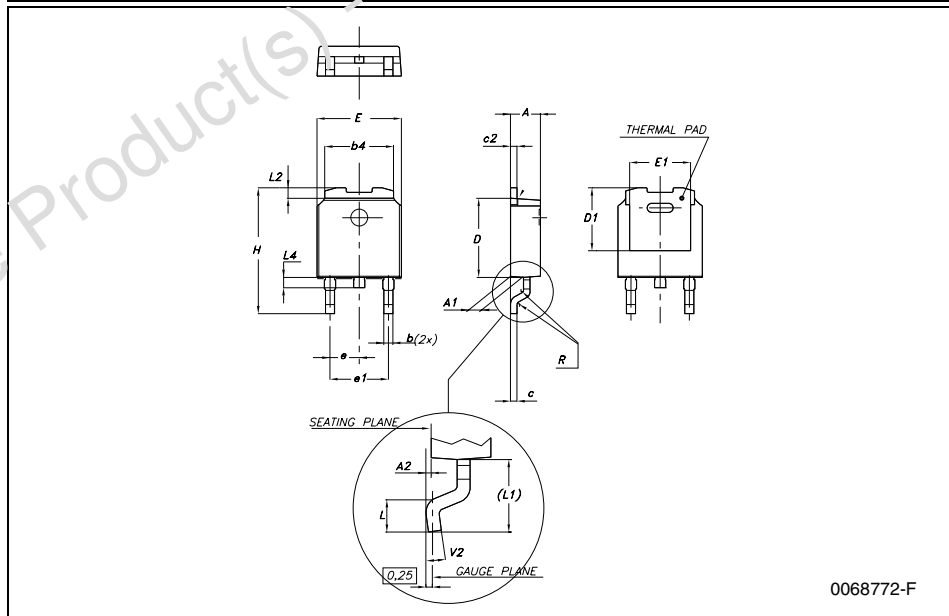

0068772-F

5 Package mechanical data

DPAK FOOTPRINT



TAPE AND REEL SHIPMENT

DIM.	mm		inch	
	MIN.	MAX.	MIN.	MAX.
A		330		12.992
B	1.5		0.059	
C	12.8	13.2	0.504	0.520
D	20.2		0.795	
G	16.4	18.4	0.645	0.724
N	50		1.968	
T		22.4		0.881

BASE QTY	BULK QTY
2500	2500

DIM.	mm		inch	
	MIN.	MAX.	MIN.	MAX.
A	6.8	7	0.267	0.275
E0	10.4	10.6	0.409	0.417
B1		12.1		0.476
D	1.5	1.6	0.059	0.063
D1	1.5		0.059	
E	1.65	1.85	0.065	0.073
F	7.4	7.6	0.291	0.299
K0	2.55	2.75	0.100	0.108
P0	3.9	4.1	0.153	0.161
P1	7.9	8.1	0.311	0.319
P2	1.9	2.1	0.075	0.082
R	40		1.574	
W	15.7	16.3	0.618	0.641

6 Revision history

Table 10. Document revision history

Date	Revision	Changes
29-Aug-2005	1	First release
02-Dec-2005	2	Modified Appendix A
07-Apr-2006	3	New template
03-May-2006	4	New value in Table 4 , new curve (see Figure 14)
25-Oct-2007	5	Updated BV_{dss} value

Please Read Carefully:

Information in this document is provided solely in connection with ST products. STMicroelectronics NV and its subsidiaries ("ST") reserve the right to make changes, corrections, modifications or improvements, to this document, and the products and services described herein at any time, without notice.

All ST products are sold pursuant to ST's terms and conditions of sale.

Purchasers are solely responsible for the choice, selection and use of the ST products and services described herein, and ST assumes no liability whatsoever relating to the choice, selection or use of the ST products and services described herein.

No license, express or implied, by estoppel or otherwise, to any intellectual property rights is granted under this document. If any part of this document refers to any third party products or services it shall not be deemed a license grant by ST for the use of such third party products or services, or any intellectual property contained therein or considered a warranty covering the use in any manner whatsoever of such third party products or services or any intellectual property contained therein.

UNLESS OTHERWISE SET FORTH IN ST'S TERMS AND CONDITIONS OF SALE ST DISCLAIMS ANY EXPRESS OR IMPLIED WARRANTY WITH RESPECT TO THE USE AND/OR SALE OF ST PRODUCTS INCLUDING WITHOUT LIMITATION IMPLIED WARRANTIES OF MERCHANTABILITY, FITNESS FOR A PARTICULAR PURPOSE (AND THEIR EQUIVALENTS UNDER THE LAWS OF ANY JURISDICTION), OR INFRINGEMENT OF ANY PATENT, COPYRIGHT OR OTHER INTELLECTUAL PROPERTY RIGHT.

UNLESS EXPRESSLY APPROVED IN WRITING BY AN AUTHORIZED REPRESENTATIVE OF ST, ST PRODUCTS ARE NOT DESIGNED, AUTHORIZED OR WARRANTED FOR USE IN MILITARY, AIR CRAFT, SPACE, LIFE SAVING, OR LIFE SUSTAINING APPLICATIONS, NOR IN PRODUCTS OR SYSTEMS, WHERE FAILURE OR MALFUNCTION MAY RESULT IN PERSONAL INJURY, DEATH, OR SEVERE PROPERTY OR ENVIRONMENTAL DAMAGE.

Resale of ST products with provisions different from the statements and/or technical features set forth in this document shall immediately void any warranty granted by ST for the ST product or service described herein and shall not create or extend in any manner whatsoever, any liability of ST.

ST and the ST logo are trademarks or registered trademarks of ST in various countries.

Information in this document supersedes and replaces all information previously supplied.

The ST logo is a registered trademark of STMicroelectronics. All other names are the property of their respective owners.

© 2007 STMicroelectronics - All rights reserved

STMicroelectronics group of companies

Australia - Belgium - Brazil - Canada - China - Czech Republic - Finland - France - Germany - Hong Kong - India - Israel - Italy - Japan - Malaysia - Malta - Morocco - Singapore - Spain - Sweden - Switzerland - United Kingdom - United States of America

www.st.com