



STF10N62K3, STFI10N62K3, STI10N62K3, STP10N62K3

N-channel 620 V, 0.68 Ω typ., 8.4 A SuperMESH3™
Power MOSFET in TO-220FP, I²PAKFP, I²PAK, TO-220 packages

Datasheet – production data

Features

Type	V _{DSS}	R _{DS(on)} max	I _D	P _w
STF10N62K3	620 V	< 0.75 Ω	8.4 A ⁽¹⁾	30 W
STFI10N62K3				
STI10N62K3			8.4 A	125 W
STP10N62K3				

1. Limited by package

- 100% avalanche tested
- Extremely high dv/dt capability
- Gate charge minimized
- Very low intrinsic capacitances
- Improved diode reverse recovery characteristics
- Zener-protected

Applications

- Switching applications

Description

These SuperMESH3™ Power MOSFETs are the result of improvements applied to STMicroelectronics' SuperMESH™ technology, combined with a new optimized vertical structure. These devices boast an extremely low on-resistance, superior dynamic performance and high avalanche capability, rendering them suitable for the most demanding applications.

Table 1. Device summary

Order codes	Marking	Package	Packaging
STF10N62K3	10N62K3	TO-220FP	Tube
STFI10N62K3	10N62K3	I ² PAKFP	
STI10N62K3	10N62K3	I ² PAK	
STP10N62K3	10N62K3	TO-220	

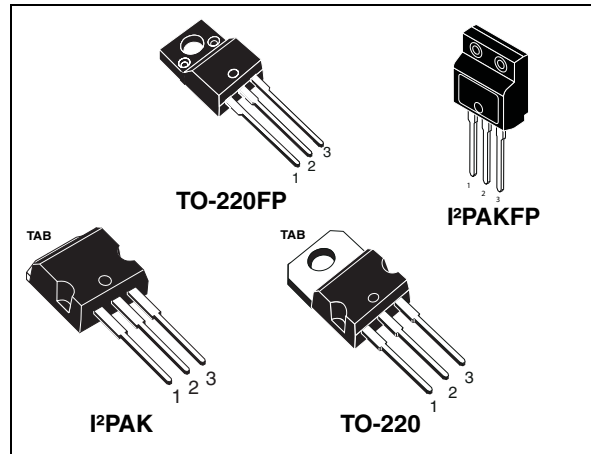
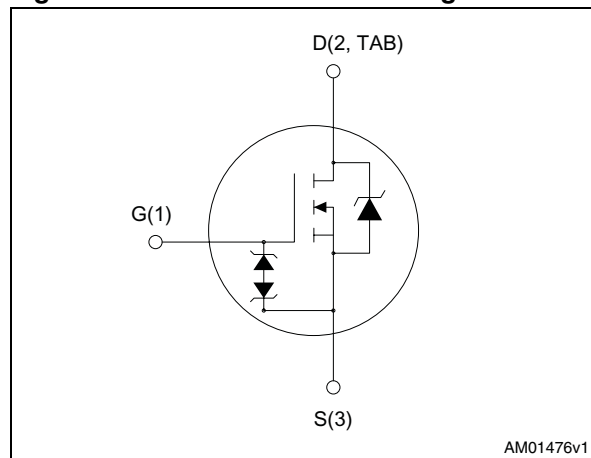

Figure 1. Internal schematic diagram



Contents

1	Electrical ratings	3
2	Electrical characteristics	4
	2.1 Electrical characteristics (curves)	6
3	Test circuits	9
4	Package mechanical data	10
5	Revision history	16

1 Electrical ratings

Table 2. Absolute maximum ratings

Symbol	Parameter	Value		Unit
		TO-220FP I ² PAKFP	I ² PAK TO-220	
V _{DS}	Drain source voltage	620		V
V _{GS}	Gate-source voltage	± 30		V
I _D	Drain current (continuous) at T _C = 25 °C	8.4 ⁽¹⁾	8.4	A
I _D	Drain current (continuous) at T _C = 100 °C	5.2 ⁽¹⁾	5.2	A
I _{DM} ⁽²⁾	Drain current (pulsed)	33.6 ⁽¹⁾	33.6	A
P _{TOT}	Total dissipation at T _C = 25 °C	30	125	W
I _{AR}	Max current during repetitive or single pulse avalanche (pulse width limited by T _{JMAX})	8		A
E _{AS}	Single pulse avalanche energy ⁽³⁾	220		mJ
dv/dt ⁽⁴⁾	Peak diode recovery voltage slope	12		V/ns
ESD	Gate-source human body model (R = 1.5 kΩ, C = 100 pF)	2.5		kV
V _{ISO}	Insulation withstand voltage (RMS) from all three leads to external heat sink (t=1 s; T _C =25 °C)	2500		V
T _j T _{stg}	Operating junction temperature Storage temperature	-55 to 150		°C

1. Limited by maximum junction temperature

2. Pulse width limited by safe operating area

3. Starting T_j = 25 °C, I_D = I_{AR}, V_{DD} = 50 V

4. I_{SD} ≤ 8.4 A, di/dt = 400 A/μs, V_{DD} = 80% V_{(BR)DSS}, V_{DS peak} ≤ V_{(BR)DSS}

Table 3. Thermal data

Symbol	Parameter	Value		Unit
		TO-220FP I ² PAKFP	I ² PAK TO-220	
R _{thj-case}	Thermal resistance junction-case max	4.17	1.00	°C/W
R _{thj-amb}	Thermal resistance junction-ambient max	62.5		°C/W

2 Electrical characteristics

(T_{case} = 25 °C unless otherwise specified)

Table 4. On /off states

Symbol	Parameter	Test conditions	Min.	Typ.	Max.	Unit
V _{(BR)DSS}	Drain-source breakdown voltage	I _D = 1 mA, V _{GS} = 0	620			V
I _{DSS}	Zero gate voltage drain current (V _{GS} = 0)	V _{DS} = 620 V V _{DS} = 620 V, T _C = 125 °C			1 50	μA μA
I _{GSS}	Gate-body leakage current (V _{DS} = 0)	V _{GS} = ± 20 V			±10	μA
V _{GS(th)}	Gate threshold voltage	V _{DS} = V _{GS} , I _D = 100 μA	3	3.75	4.5	V
R _{DS(on)}	Static drain-source on resistance	V _{GS} = 10 V, I _D = 4 A		0.68	0.75	Ω

Table 5. Dynamic

Symbol	Parameter	Test conditions	Min.	Typ.	Max.	Unit
g _{fs} ⁽¹⁾	Forward transconductance	V _{DS} = 15 V, I _D = 4 A	-	6	-	S
C _{iss} C _{oss} C _{rss}	Input capacitance Output capacitance Reverse transfer capacitance	V _{DS} = 50 V, f = 1 MHz, V _{GS} = 0	-	1250 138 16	-	pF pF pF
C _{o(tr)} ⁽²⁾	Equivalent capacitance time related	V _{DS} = 0 to 496 V, V _{GS} = 0	-	56	-	pF
C _{o(er)} ⁽³⁾	Equivalent capacitance energy related	V _{DS} = 0 to 496 V, V _{GS} = 0	-	38	-	pF
R _G	Gate input resistance	f = 1 MHz Gate DC Bias = 0 Test signal level = 20 mV open drain	-	3.5	-	Ω
Q _g Q _{gs} Q _{gd}	Total gate charge Gate-source charge Gate-drain charge	V _{DD} = 496 V, I _D = 8 A, V _{GS} = 10 V (see Figure 18)	-	42 7.4 23	-	nC nC nC

1. Pulsed: pulse duration = 300 μs, duty cycle 1.5%
2. C_{oss eq} time related is defined as a constant equivalent capacitance giving the same charging time as C_{oss} when V_{DS} increases from 0 to 80% V_{DSS}
3. C_{oss eq} energy related is defined as a constant equivalent capacitance giving the same stored energy as C_{oss} when V_{DS} increases from 0 to 80% V_{DSS}

Table 6. Switching times

Symbol	Parameter	Test conditions	Min.	Typ.	Max.	Unit
$t_{d(on)}$	Turn-on delay time	$V_{DD} = 310\text{ V}$, $I_D = 4\text{ A}$, $R_G = 4.7\ \Omega$, $V_{GS} = 10\text{ V}$ (see Figure 17)	-	14.5	-	ns
t_r	Rise time			15		ns
$t_{d(off)}$	Turn-off-delay time			41		ns
t_f	Fall time			31		ns

Table 7. Source drain diode

Symbol	Parameter	Test conditions	Min.	Typ.	Max.	Unit
I_{SD}	Source-drain current		-		8.4	A
$I_{SDM}^{(1)}$	Source-drain current (pulsed)				33.6	A
$V_{SD}^{(2)}$	Forward on voltage	$I_{SD} = 8\text{ A}$, $V_{GS} = 0$	-		1.5	V
t_{rr}	Reverse recovery time	$I_{SD} = 8\text{ A}$, $di/dt = 100\text{ A}/\mu\text{s}$ $V_{DD} = 60\text{ V}$ (see Figure 22)	-	320		ns
Q_{rr}	Reverse recovery charge			2		μC
I_{RRM}	Reverse recovery current			13		A
t_{rr}	Reverse recovery time	$I_{SD} = 8\text{ A}$, $di/dt = 100\text{ A}/\mu\text{s}$ $V_{DD} = 60\text{ V}$, $T_j = 150\text{ }^\circ\text{C}$ (see Figure 22)	-	410		ns
Q_{rr}	Reverse recovery charge			2.9		μC
I_{RRM}	Reverse recovery current			14		A

1. Pulse width limited by safe operating area

2. Pulsed: Pulse duration = 300 μs , duty cycle 1.5%

Table 8. Gate-source Zener diode

Symbol	Parameter	Test conditions	Min.	Typ.	Max.	Unit
$V_{(BR)GSO}$	Gate-source breakdown voltage ($I_D = 0$)	$I_{GS} = \pm 1\text{ mA}$	30	-	-	V

The built-in back-to-back Zener diodes have specifically been designed to enhance not only the device's ESD capability, but also to make them safely absorb possible voltage transients that may occasionally be applied from gate to source. In this respect the Zener voltage is appropriate to achieve an efficient and cost-effective intervention to protect the device's integrity. These integrated Zener diodes thus avoid the usage of external components.

2.1 Electrical characteristics (curves)

Figure 2. Safe operating area for TO-220FP, I²PAKFP

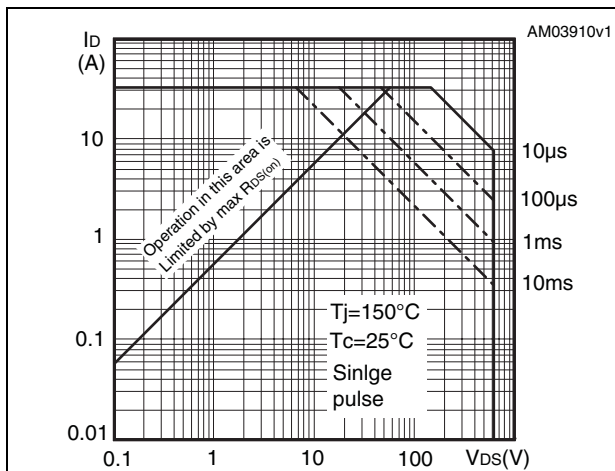

Figure 3. Thermal impedance for TO-220FP, I²PAKFP

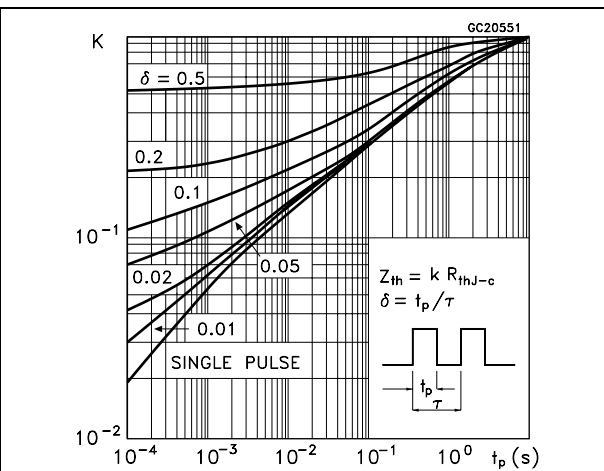

Figure 4. Safe operating area for I²PAK, TO-220

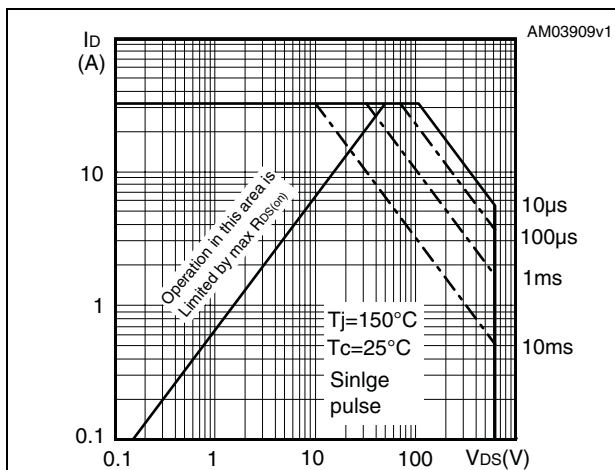

Figure 5. Thermal impedance for I²PAK, TO-220

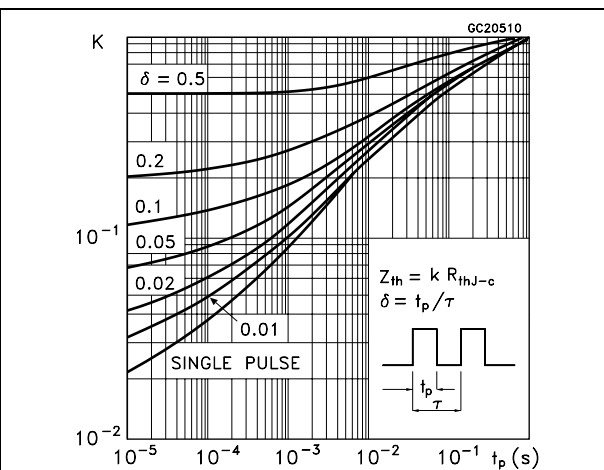

Figure 6. Output characteristics

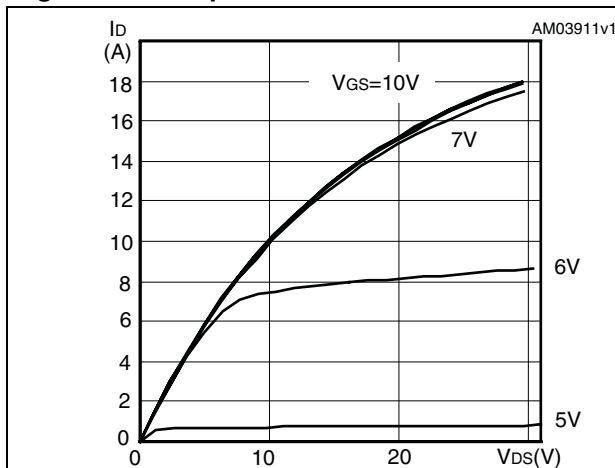

Figure 7. Transfer characteristics

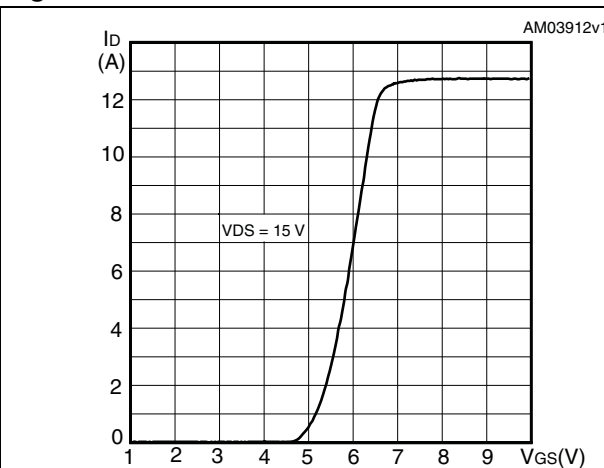

Figure 8. Normalized BV_{DSS} vs temperature

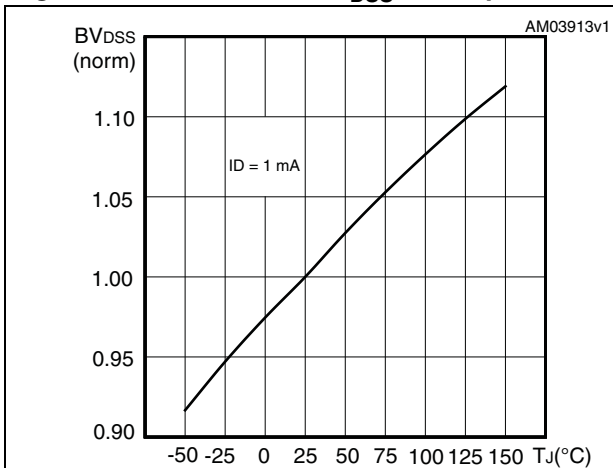

Figure 9. Static drain-source on-resistance

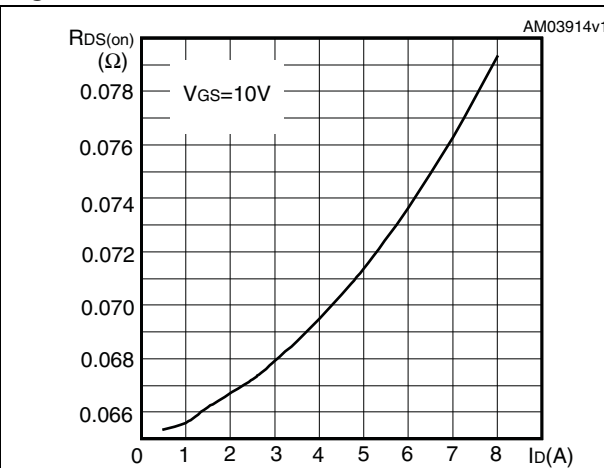

Figure 10. Output capacitance stored energy

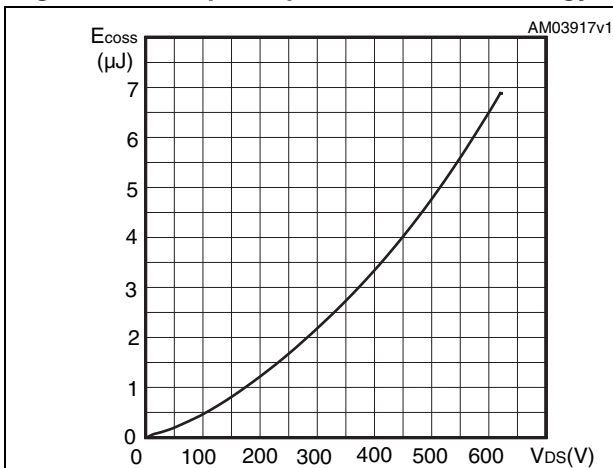

Figure 11. Capacitance variations

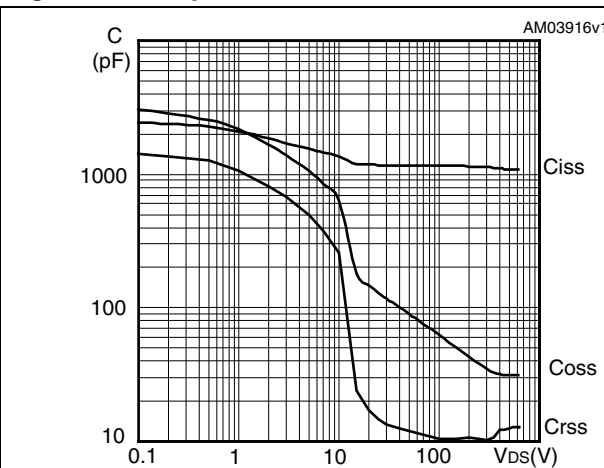

Figure 12. Gate charge vs gate-source voltage

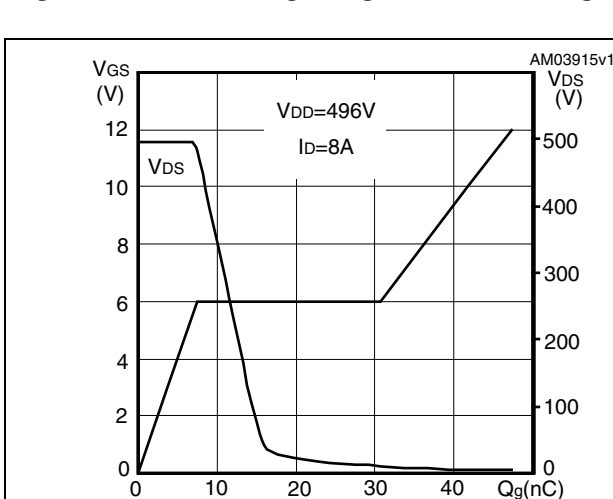

Figure 13. Normalized on-resistance vs temperature

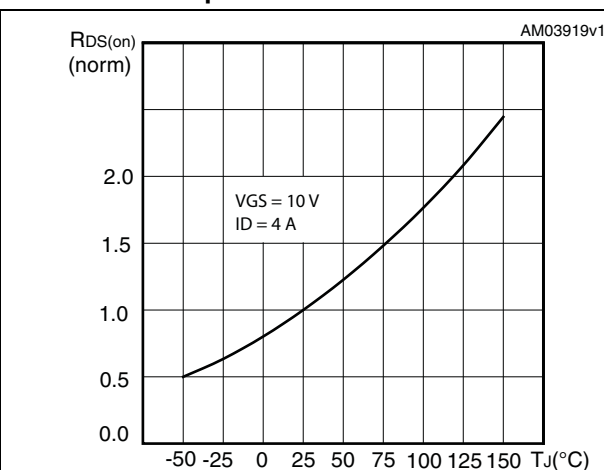

Figure 14. Normalized gate threshold voltage vs temperature

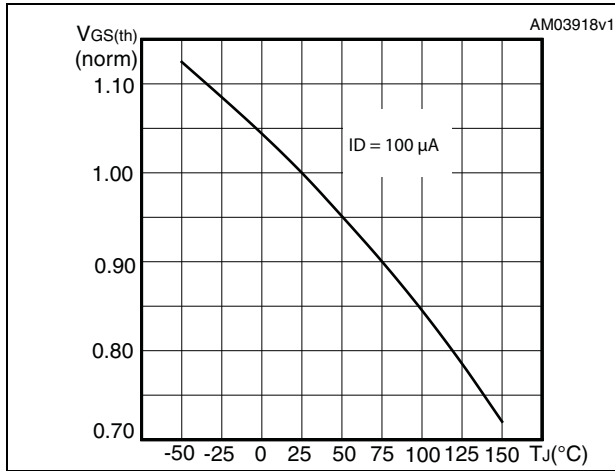

Figure 15. Maximum avalanche energy vs temperature

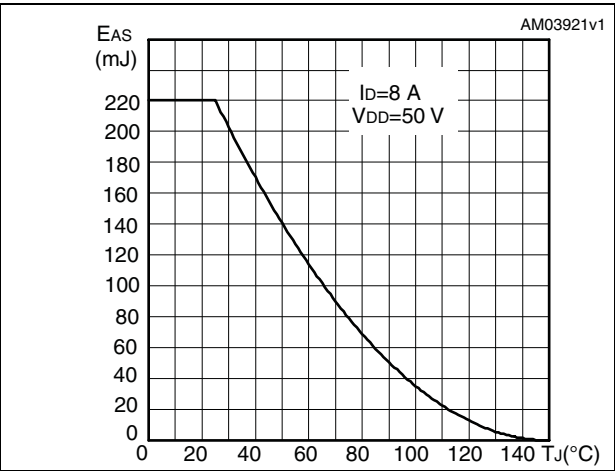
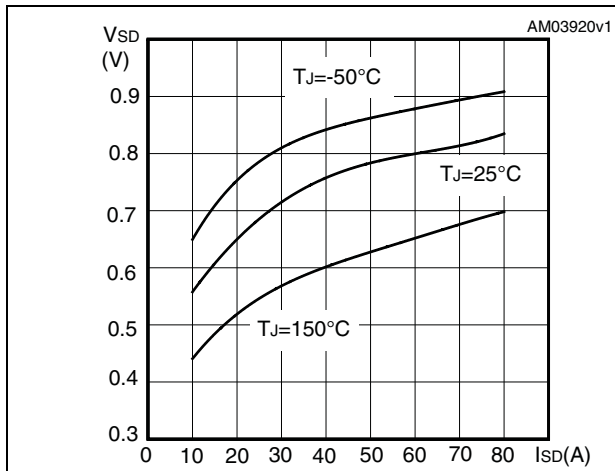
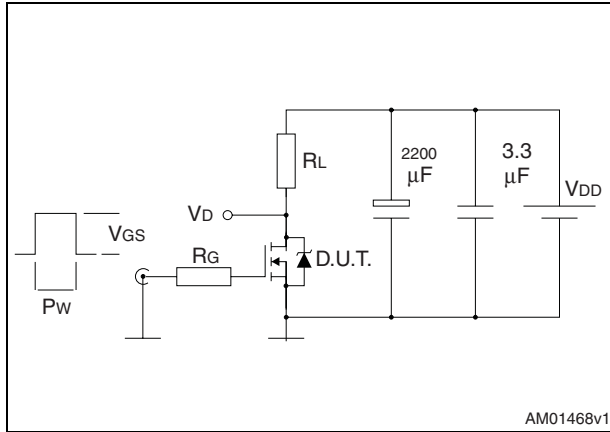

Figure 16. Source-drain diode forward characteristics



3 Test circuits

Figure 17. Switching times test circuit for resistive load



AM01468v1

Figure 18. Gate charge test circuit

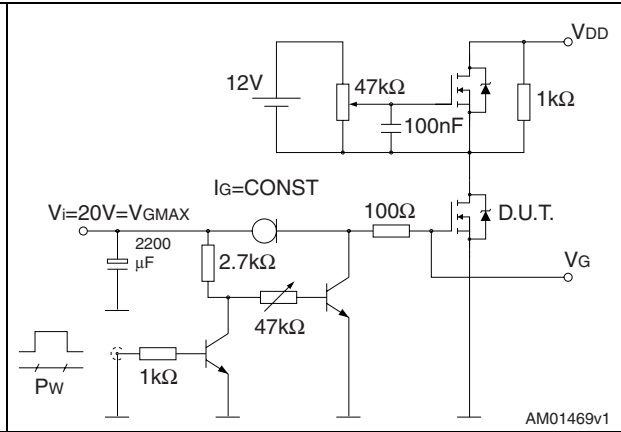

AM01469v1

Figure 19. Test circuit for inductive load switching and diode recovery times

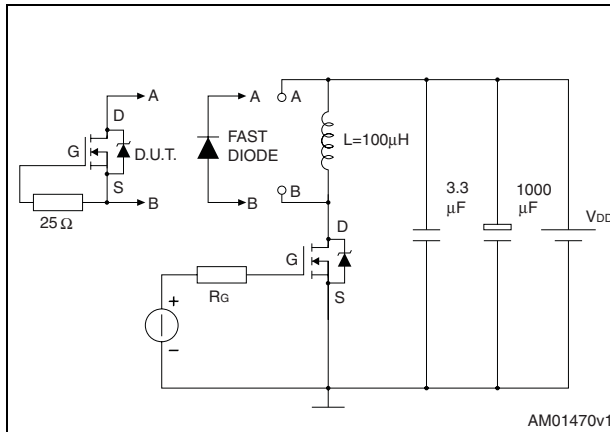

AM01470v1

Figure 20. Unclamped inductive load test circuit

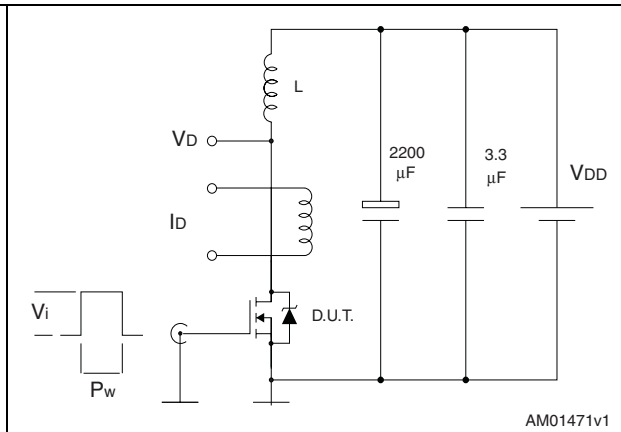

AM01471v1

Figure 21. Unclamped inductive waveform

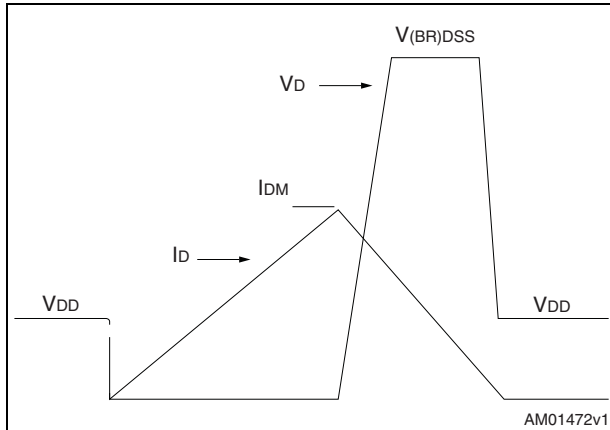

AM01472v1

Figure 22. Switching time waveform

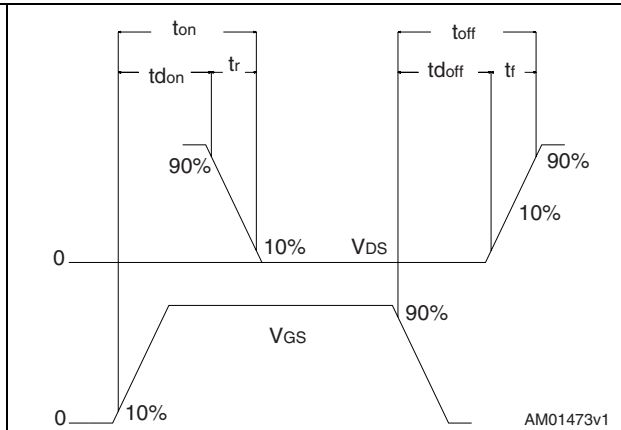

AM01473v1

4 Package mechanical data

In order to meet environmental requirements, ST offers these devices in different grades of ECOPACK® packages, depending on their level of environmental compliance. ECOPACK® specifications, grade definitions and product status are available at: www.st.com. ECOPACK is an ST trademark.

Table 9. TO-220FP mechanical data

Dim.	mm		
	Min.	Typ.	Max.
A	4.4		4.6
B	2.5		2.7
D	2.5		2.75
E	0.45		0.7
F	0.75		1
F1	1.15		1.70
F2	1.15		1.70
G	4.95		5.2
G1	2.4		2.7
H	10		10.4
L2		16	
L3	28.6		30.6
L4	9.8		10.6
L5	2.9		3.6
L6	15.9		16.4
L7	9		9.3
Dia	3		3.2

Figure 23. TO-220FP drawing

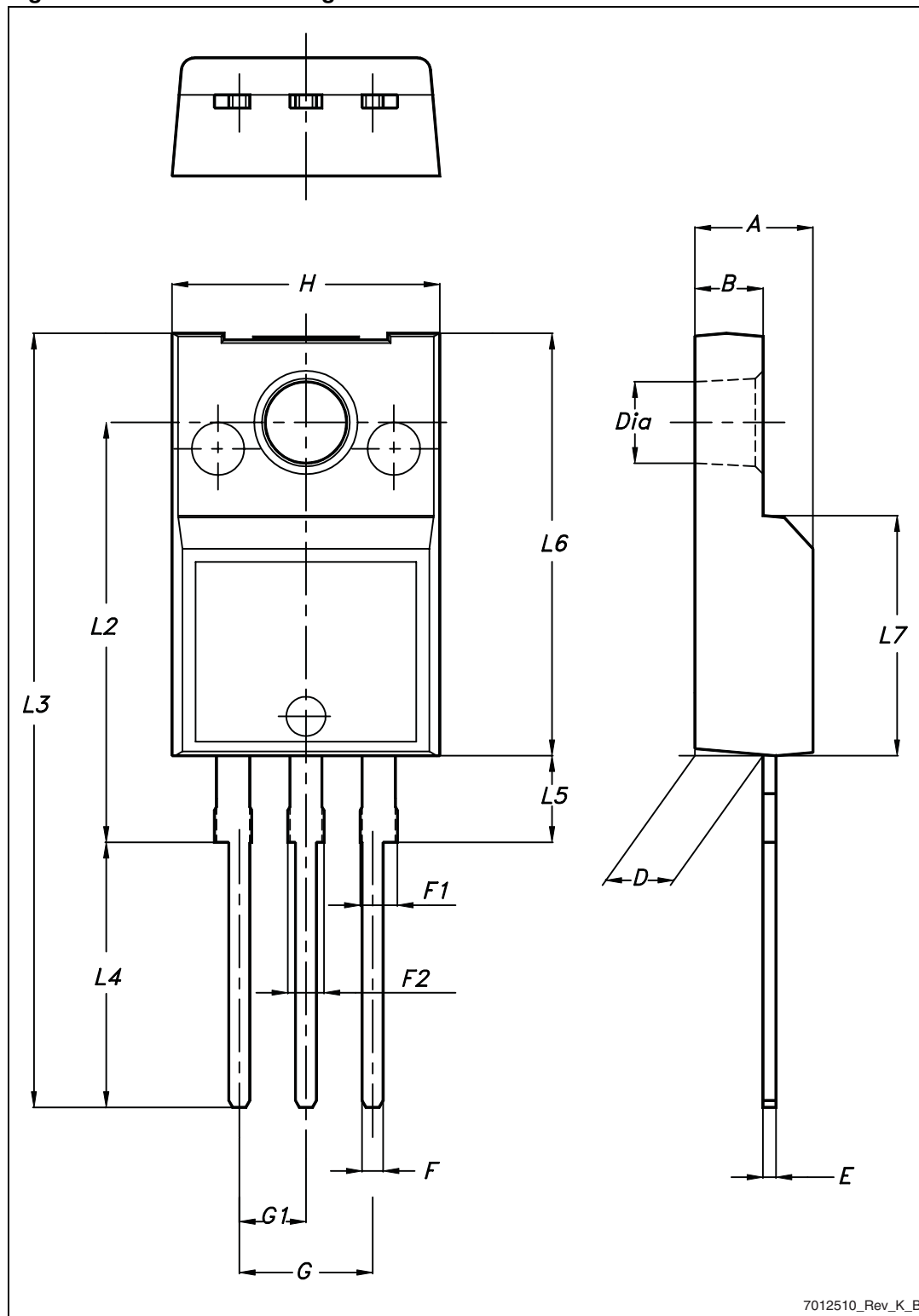

Table 10. I²PAKFP (TO-281) mechanical data

Dim.	mm		
	Min.	Typ.	Max.
A	4.40		4.60
B	2.50		2.70
D	2.50		2.75
D1	0.65		0.85
E	0.45		0.70
F	0.75		1.00
F1			1.20
G	4.95	-	5.20
H	10.00		10.40
L1	21.00		23.00
L2	13.20		14.10
L3	10.55		10.85
L4	2.70		3.20
L5	0.85		1.25
L6	7.30		7.50

Figure 24. I²PAKFP (TO-281) drawing

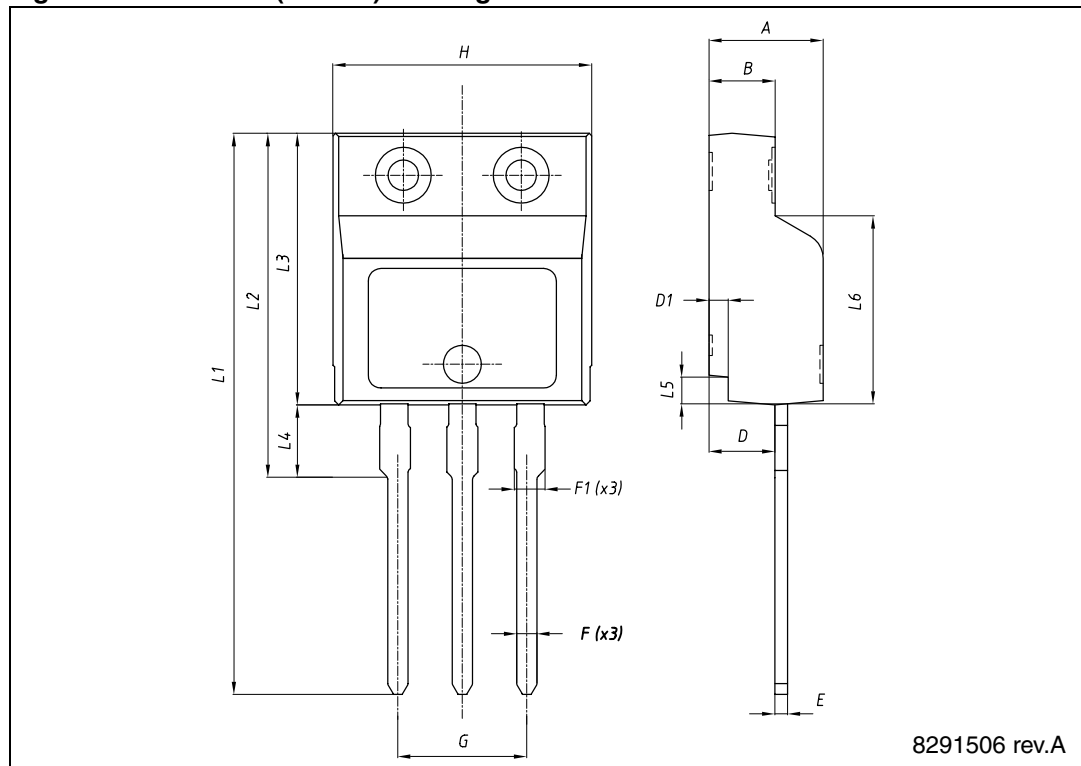
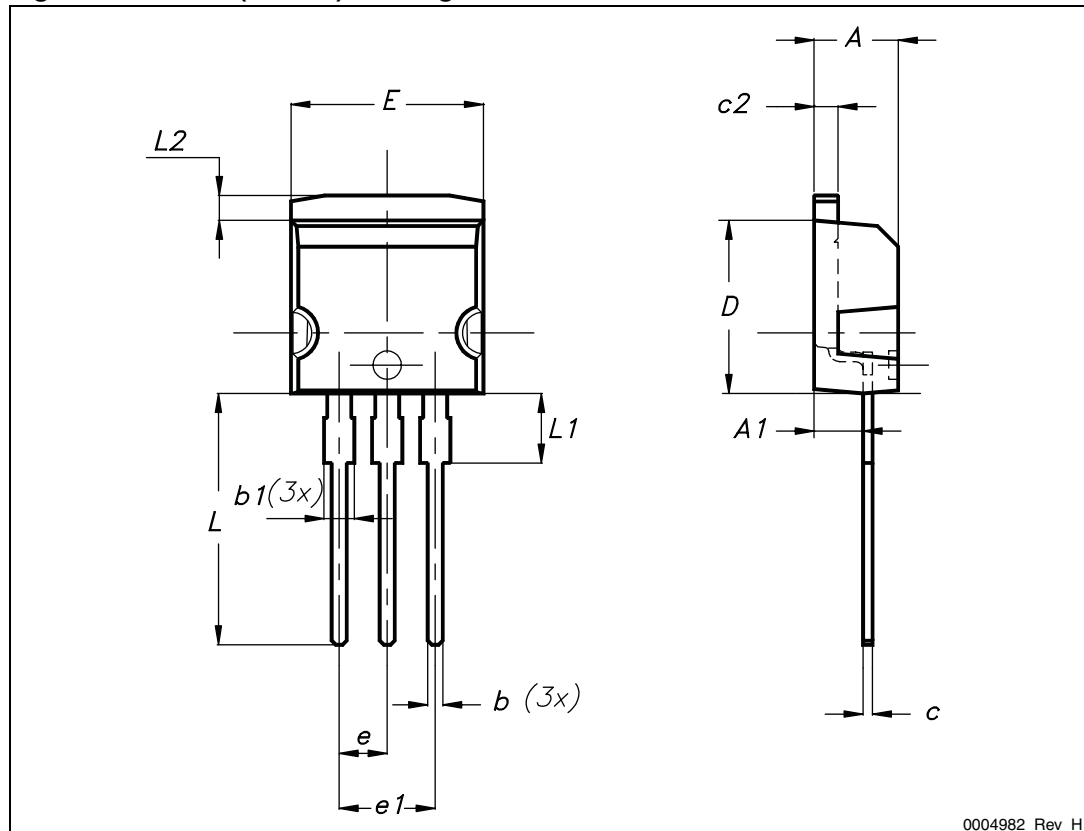

Table 11. I²PAK (TO-262) mechanical data

DIM.	mm.		
	min.	typ	max.
A	4.40		4.60
A1	2.40		2.72
b	0.61		0.88
b1	1.14		1.70
c	0.49		0.70
c2	1.23		1.32
D	8.95		9.35
e	2.40		2.70
e1	4.95		5.15
E	10		10.40
L	13		14
L1	3.50		3.93
L2	1.27		1.40

Figure 25. I²PAK (TO-262) drawing



0004982_Rev_H

Table 12. TO-220 type A mechanical data

Dim.	mm		
	Min.	Typ.	Max.
A	4.40		4.60
b	0.61		0.88
b1	1.14		1.70
c	0.48		0.70
D	15.25		15.75
D1		1.27	
E	10		10.40
e	2.40		2.70
e1	4.95		5.15
F	1.23		1.32
H1	6.20		6.60
J1	2.40		2.72
L	13		14
L1	3.50		3.93
L20		16.40	
L30		28.90	
ØP	3.75		3.85
Q	2.65		2.95

Figure 26. TO-220 type A drawing

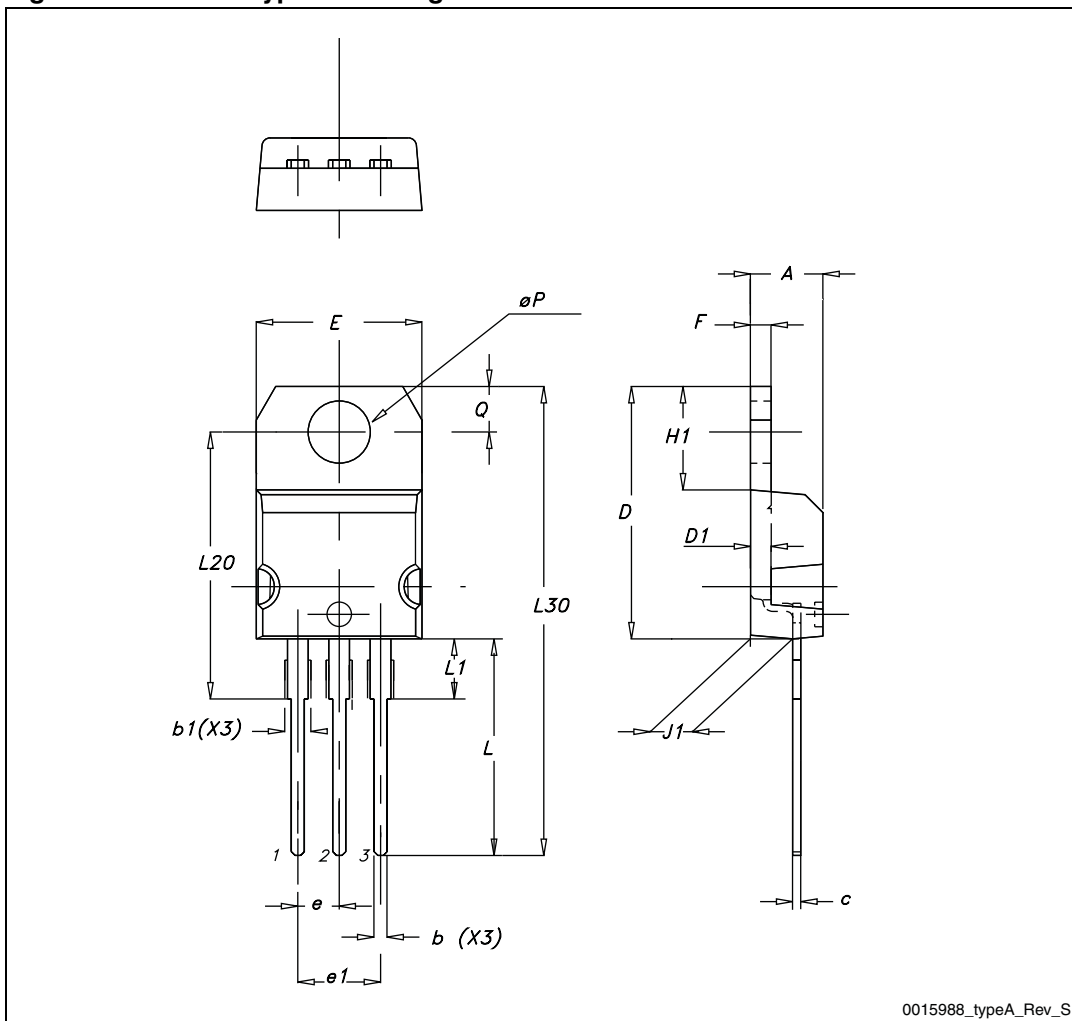

5 Revision history

Table 13. Document revision history

Date	Revision	Changes
08-Jun-2009	1	First release.
22-Jun-2009	2	Added new package, mechanical data: I ² PAK
06-Aug-2012	3	Added package, mechanical data: I ² PAKFP Updated Table 1: Device summary , Table 2: Absolute maximum ratings , Table 3: Thermal data , Table 4: On /off states . Minor text changes.
13-Sep-2012	4	Changed value in the title from 3.8 A to 8.4 A.

Please Read Carefully:

Information in this document is provided solely in connection with ST products. STMicroelectronics NV and its subsidiaries ("ST") reserve the right to make changes, corrections, modifications or improvements, to this document, and the products and services described herein at any time, without notice.

All ST products are sold pursuant to ST's terms and conditions of sale.

Purchasers are solely responsible for the choice, selection and use of the ST products and services described herein, and ST assumes no liability whatsoever relating to the choice, selection or use of the ST products and services described herein.

No license, express or implied, by estoppel or otherwise, to any intellectual property rights is granted under this document. If any part of this document refers to any third party products or services it shall not be deemed a license grant by ST for the use of such third party products or services, or any intellectual property contained therein or considered as a warranty covering the use in any manner whatsoever of such third party products or services or any intellectual property contained therein.

UNLESS OTHERWISE SET FORTH IN ST'S TERMS AND CONDITIONS OF SALE ST DISCLAIMS ANY EXPRESS OR IMPLIED WARRANTY WITH RESPECT TO THE USE AND/OR SALE OF ST PRODUCTS INCLUDING WITHOUT LIMITATION IMPLIED WARRANTIES OF MERCHANTABILITY, FITNESS FOR A PARTICULAR PURPOSE (AND THEIR EQUIVALENTS UNDER THE LAWS OF ANY JURISDICTION), OR INFRINGEMENT OF ANY PATENT, COPYRIGHT OR OTHER INTELLECTUAL PROPERTY RIGHT.

UNLESS EXPRESSLY APPROVED IN WRITING BY TWO AUTHORIZED ST REPRESENTATIVES, ST PRODUCTS ARE NOT RECOMMENDED, AUTHORIZED OR WARRANTED FOR USE IN MILITARY, AIR CRAFT, SPACE, LIFE SAVING, OR LIFE SUSTAINING APPLICATIONS, NOR IN PRODUCTS OR SYSTEMS WHERE FAILURE OR MALFUNCTION MAY RESULT IN PERSONAL INJURY, DEATH, OR SEVERE PROPERTY OR ENVIRONMENTAL DAMAGE. ST PRODUCTS WHICH ARE NOT SPECIFIED AS "AUTOMOTIVE GRADE" MAY ONLY BE USED IN AUTOMOTIVE APPLICATIONS AT USER'S OWN RISK.

Resale of ST products with provisions different from the statements and/or technical features set forth in this document shall immediately void any warranty granted by ST for the ST product or service described herein and shall not create or extend in any manner whatsoever, any liability of ST.

ST and the ST logo are trademarks or registered trademarks of ST in various countries.

Information in this document supersedes and replaces all information previously supplied.

The ST logo is a registered trademark of STMicroelectronics. All other names are the property of their respective owners.

© 2012 STMicroelectronics - All rights reserved

STMicroelectronics group of companies

Australia - Belgium - Brazil - Canada - China - Czech Republic - Finland - France - Germany - Hong Kong - India - Israel - Italy - Japan - Malaysia - Malta - Morocco - Philippines - Singapore - Spain - Sweden - Switzerland - United Kingdom - United States of America

www.st.com

