

## Automotive-grade N-channel 30 V, 0.0076 $\Omega$ typ., 56 A STripFET™ H5 Power MOSFET in a PowerFLAT™ 5x6 package

Datasheet — production data

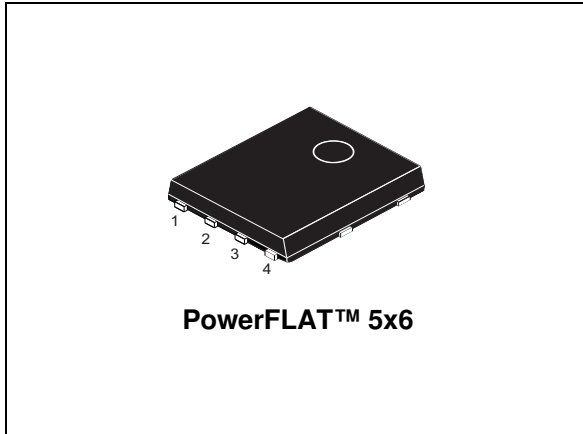
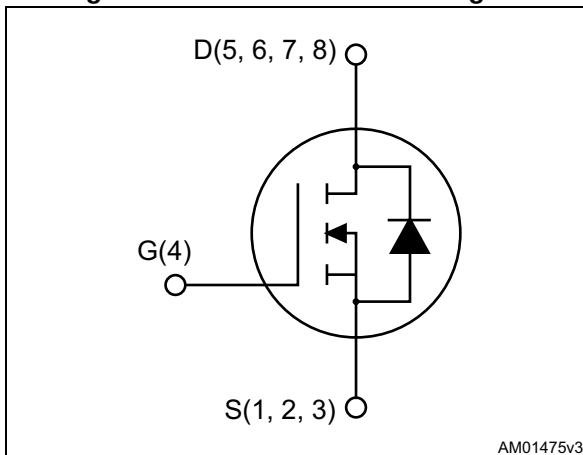

Figure 1. Internal schematic diagram



### Features

Order code	$V_{DS}$	$R_{DS(on) max}$	$I_D$
STL58N3LLH5	30 V	0.009 $\Omega$	56 A

- Designed for automotive applications and AEC-Q101 qualified
- Low on-resistance
- High avalanche ruggedness
- Low gate drive power loss
- Wettable flank package

### Applications

- Switching applications

### Description

This device is an N-channel Power MOSFET developed using STMicroelectronics' STripFET™ H5 technology. The device has been optimized to achieve very low on-state resistance, contributing to a FoM that is among the best in its class.

Table 1. Device summary

Order code	Marking	Package	Packaging
STL58N3LLH5	58N3LH5	PowerFLAT™ 5x6	Tape and reel

# Contents

<b>1</b>	<b>Electrical ratings</b> .....	<b>3</b>
<b>2</b>	<b>Electrical characteristics</b> .....	<b>4</b>
2.1	Electrical characteristics (curves) .....	6
<b>3</b>	<b>Test circuits</b> .....	<b>8</b>
<b>4</b>	<b>Package mechanical data</b> .....	<b>9</b>
<b>5</b>	<b>Packaging mechanical data</b> .....	<b>13</b>
<b>6</b>	<b>Revision history</b> .....	<b>15</b>

# 1 Electrical ratings

**Table 2. Absolute maximum ratings**

Symbol	Parameter	Value	Unit
$V_{DS}$	Drain-source voltage	30	V
$V_{GS}$	Gate-source voltage	+22 / -20	V
$I_D^{(1)}$	Drain current (continuous) at $T_C = 25^\circ\text{C}$	64	A
$I_D^{(1)}$	Drain current (continuous) at $T_C = 100^\circ\text{C}$	45	A
$I_D^{(2)}$	Drain current (continuous) at $T_{pcb} = 25^\circ\text{C}$	16	A
$I_D^{(2)}$	Drain current (continuous) at $T_{pcb} = 100^\circ\text{C}$	11.5	A
$I_{DM}^{(1)(3)}$	Drain current (pulsed)	224	A
$I_{DM}^{(2)(3)}$	Drain current (pulsed)	75	A
$P_{TOT}^{(1)}$	Total dissipation at $T_C = 25^\circ\text{C}$	62.5	W
$P_{TOT}^{(2)}$	Total dissipation at $T_{pcb} = 25^\circ\text{C}$	4.8	W
$E_{AS}^{(4)}$	Single pulse avalanche energy	150	mJ
$T_J$	Operating junction temperature	-55 to 175	$^\circ\text{C}$
$T_{stg}$	Storage temperature		

1. The value is rated according to  $R_{thj-c}$
2. The value is rated according to  $R_{thj-pcb}$
3. Pulse width limited by safe operating area
4. Starting  $T_j = 25^\circ\text{C}$ ,  $I_D = 56\text{ A}$ ,  $V_{DD} = 50\text{ V}$

**Table 3. Thermal resistance**

Symbol	Parameter	Value	Unit
$R_{thj-case}$	Thermal resistance junction-case	2	$^\circ\text{C}/\text{W}$
$R_{thj-pcb}^{(1)}$	Thermal resistance junction-pcb	31.3	$^\circ\text{C}/\text{W}$

1. When mounted on FR-4 board of 1inch<sup>2</sup>, 2oz Cu,  $t < 10\text{ sec}$

## 2 Electrical characteristics

( $T_{CASE} = 25\text{ °C}$  unless otherwise specified)

**Table 4. On/off states**

Symbol	Parameter	Test conditions	Min.	Typ.	Max.	Unit
$V_{(BR)DSS}$	Drain-source breakdown voltage	$V_{GS} = 0\text{ V}$ , $I_D = 250\text{ }\mu\text{A}$	30			V
$I_{DSS}$	Zero gate voltage drain current	$V_{GS} = 0\text{ V}$ , $V_{DS} = 30\text{ V}$ ,			1	$\mu\text{A}$
		$V_{GS} = 0\text{ V}$ $V_{DS} = 30\text{ V}$ , $T_C = 125\text{ °C}$			10	$\mu\text{A}$
$I_{GSS}$	Gate body leakage current	$V_{DS} = 0\text{ V}$ , $V_{GS} = +22 / -20\text{ V}$			$\pm 100$	nA
$V_{GS(th)}$	Gate threshold voltage	$V_{DS} = V_{GS}$ , $I_D = 250\text{ }\mu\text{A}$	1		2.5	V
$R_{DS(on)}$	Static drain-source on- resistance	$V_{GS} = 10\text{ V}$ , $I_D = 7.5\text{ A}$		0.0076	0.009	$\Omega$
		$V_{GS} = 4.5\text{ V}$ , $I_D = 7.5\text{ A}$		0.0099	0.0112	$\Omega$

**Table 5. Dynamic**

Symbol	Parameter	Test conditions	Min.	Typ.	Max.	Unit
$C_{iss}$	Input capacitance	$V_{DS} = 2.5\text{ V}$ , $f = 1\text{ MHz}$ , $V_{GS} = 0\text{ V}$	-	950		pF
$C_{oss}$	Output capacitance		-	193		pF
$C_{rss}$	Reverse transfer capacitance		-	27		pF
$Q_g$	Total gate charge	$V_{DD} = 15\text{ V}$ , $I_D = 15\text{ A}$ , $V_{GS} = 4.5\text{ V}$ (see <a href="#">Figure 14</a> )	-	6.5	10	nC
$Q_{gs}$	Gate-source charge		-	3.3		nC
$Q_{gd}$	Gate-drain charge		-	2.4		nC
$R_g$	Gate input resistance	$f = 1\text{ MHz}$ , gate DC Bias = 0, test signal level = 20 mV, $I_D = 0\text{ A}$	-	1.7	2.5	$\Omega$

Table 6. Switching times

Symbol	Parameter	Test conditions	Min.	Typ.	Max.	Unit
$t_{d(on)}$	Turn-on delay time	$V_{DD} = 15\text{ V}$ , $I_D = 7.5\text{ A}$ , $R_G = 4.7\ \Omega$ , $V_{GS} = 10\text{ V}$ (see <a href="#">Figure 13</a> )	-	10.8	-	ns
$t_r$	Rise time		-	15.6	-	ns
$t_{d(off)}$	Turn-off delay time		-	14.2	-	ns
$t_f$	Fall time		-	6	-	ns

Table 7. Source drain diode

Symbol	Parameter	Test conditions	Min	Typ.	Max	Unit
$I_{SD}$	Source-drain current		-		56	A
$I_{SDM}^{(1)}$	Source-drain current (pulsed)		-		224	A
$V_{SD}^{(2)}$	Forward on voltage	$I_{SD} = 15\text{ A}$ , $V_{GS} = 0\text{ V}$	-		1.1	V
$t_{rr}$	Reverse recovery time	$I_{SD} = 15\text{ A}$ , $di/dt = 100\text{ A}/\mu\text{s}$ , $V_{DD} = 25\text{ V}$ , $T_J = 150\text{ }^\circ\text{C}$	-	20	36	ns
$Q_{rr}$	Reverse recovery charge		-	10	18	nC
$I_{RRM}$	Reverse recovery current		-	1		A

1. Pulse width limited by safe operating area
2. Pulsed: pulse duration= 300  $\mu\text{s}$ , duty cycle 1.5%

## 2.1 Electrical characteristics (curves)

Figure 2. Safe operating area

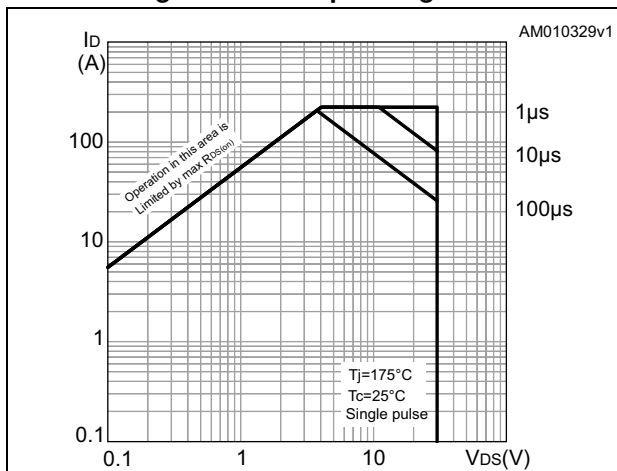

Figure 3. Thermal impedance

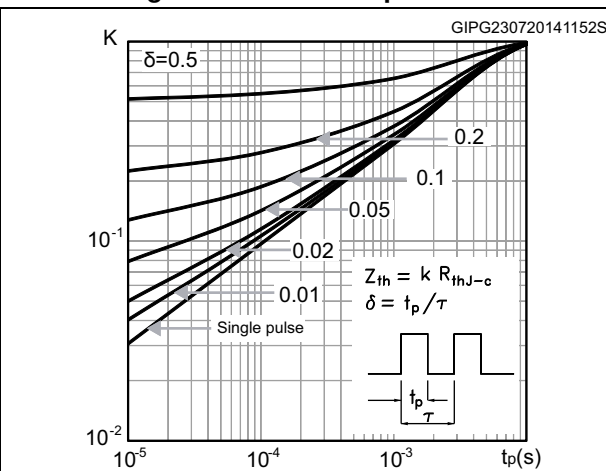

Figure 4. Output characteristics

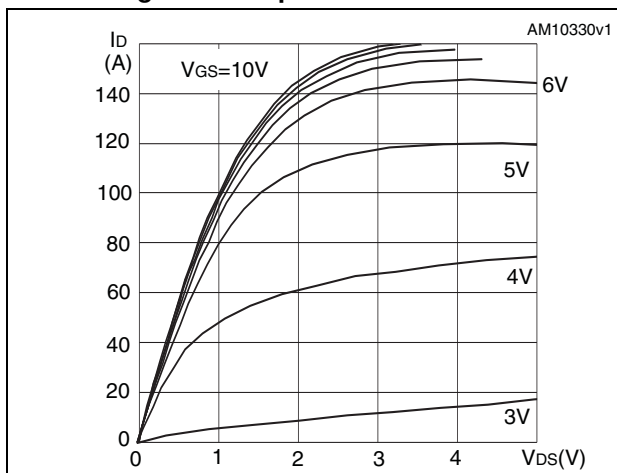

Figure 5. Transfer characteristics

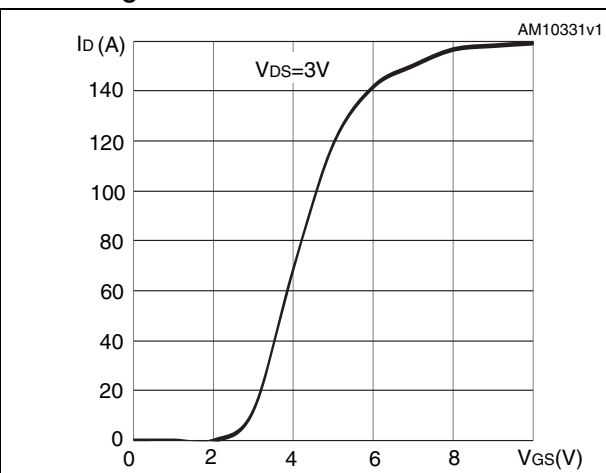

Figure 6. Normalized  $V_{(BR)DSS}$  vs temperature

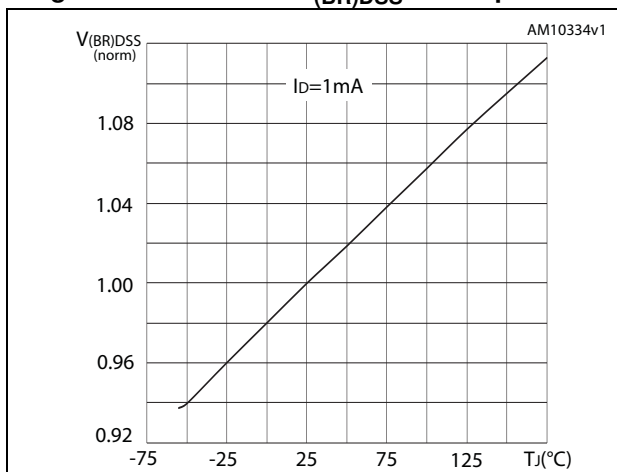

Figure 7. Static drain-source on-resistance

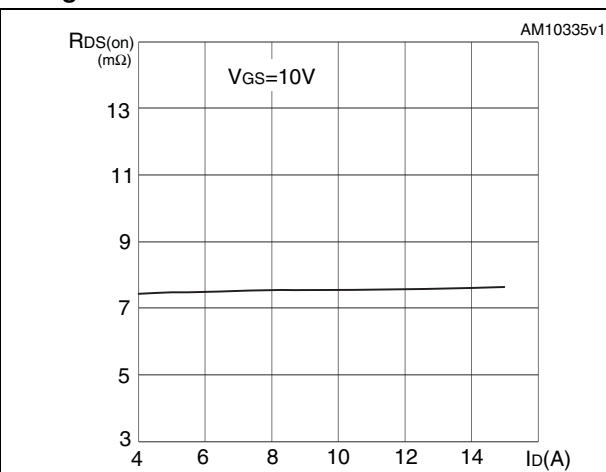

Figure 8. Gate charge vs gate-source voltage

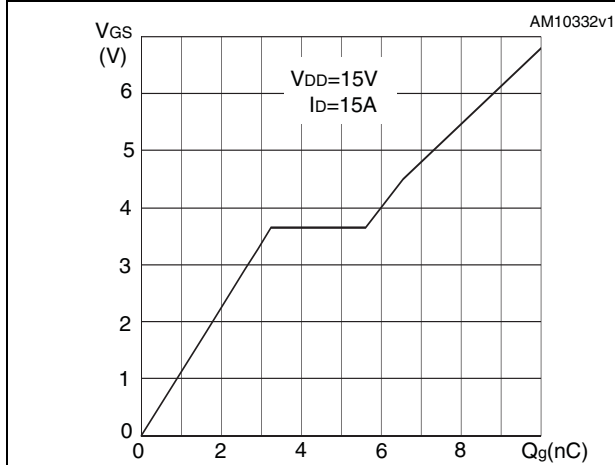

Figure 9. Capacitance variations

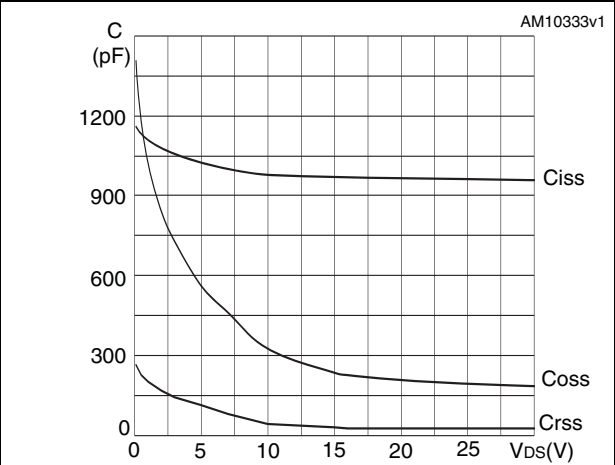

Figure 10. Normalized gate threshold voltage vs temperature

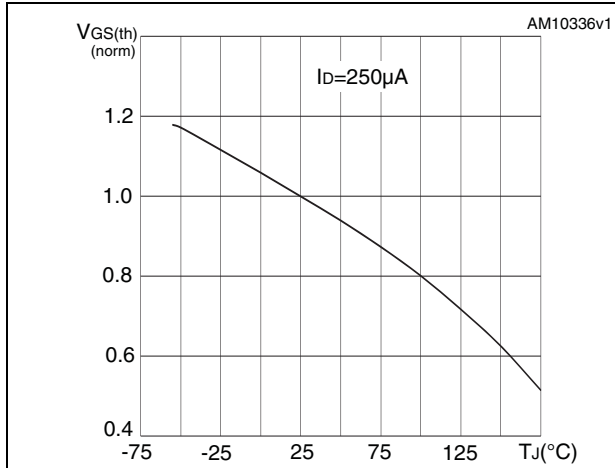

Figure 11. Normalized on-resistance vs temperature

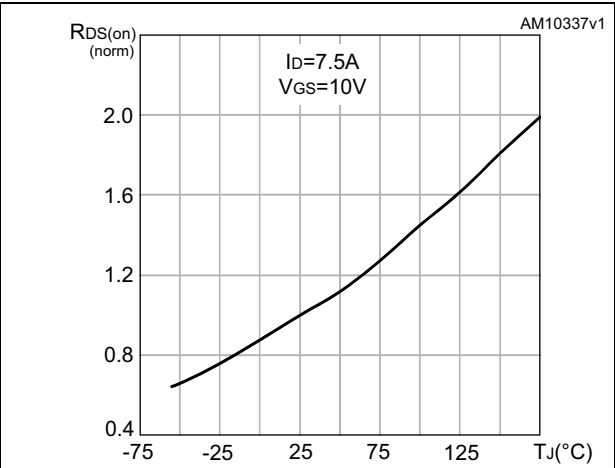
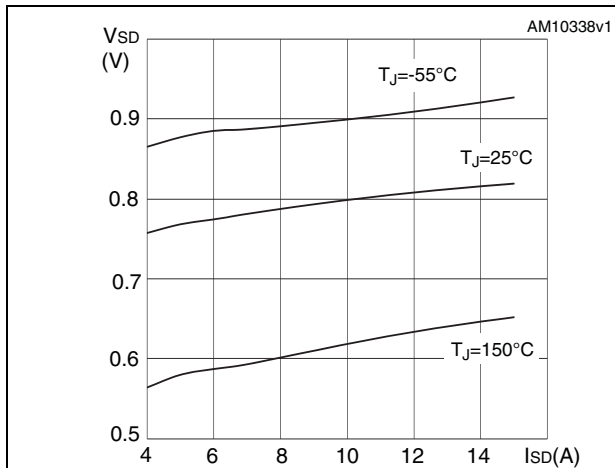

Figure 12. Source-drain diode forward characteristics



### 3 Test circuits

Figure 13. Switching times test circuit for resistive load

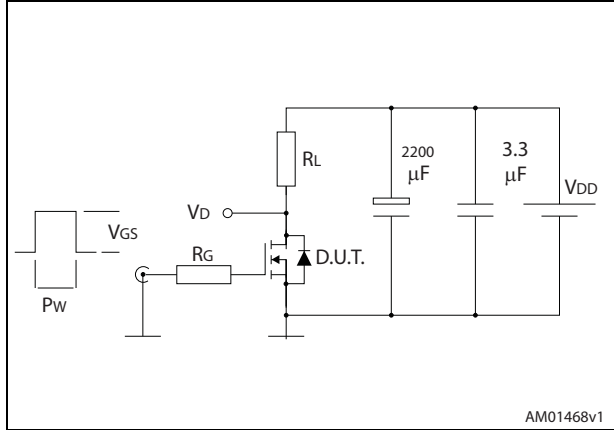

Figure 14. Gate charge test circuit

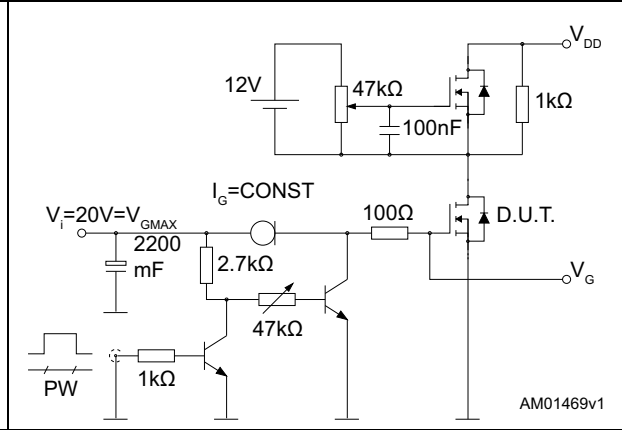

Figure 15. Test circuit for inductive load switching and diode recovery times

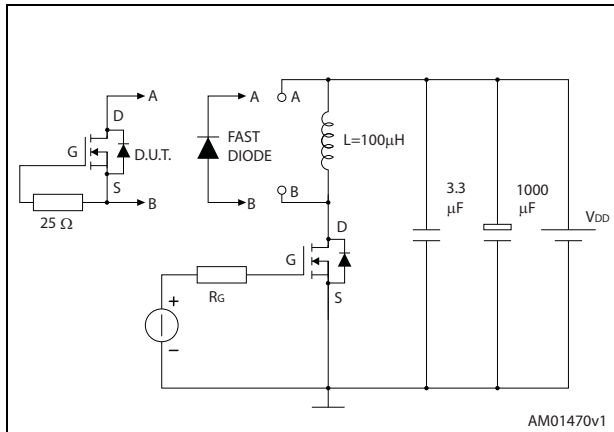

Figure 16. Unclamped inductive load test circuit

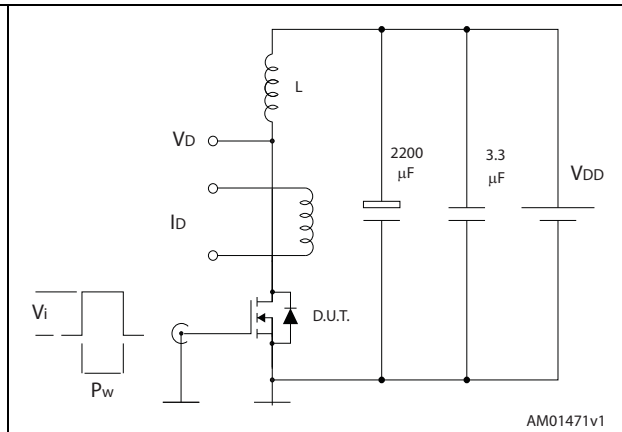

Figure 17. Unclamped inductive waveform

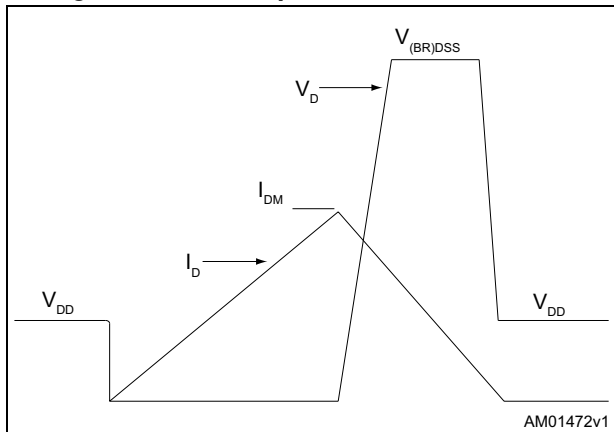
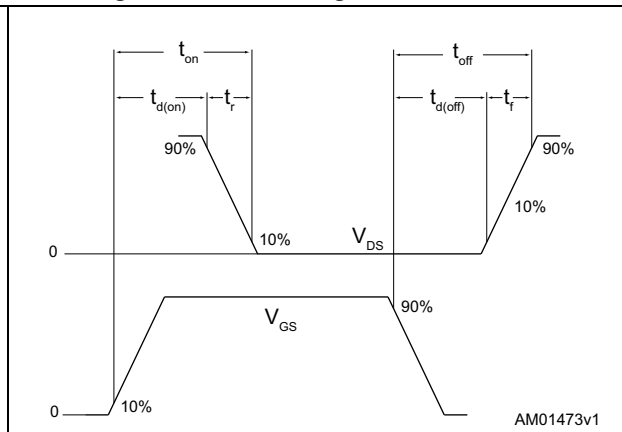

Figure 18. Switching time waveform





## 4 Package mechanical data

In order to meet environmental requirements, ST offers these devices in different grades of ECOPACK<sup>®</sup> packages, depending on their level of environmental compliance. ECOPACK<sup>®</sup> specifications, grade definitions and product status are available at: [www.st.com](http://www.st.com). ECOPACK<sup>®</sup> is an ST trademark.

Figure 19. PowerFLAT™ 5x6 WF type S-R drawing

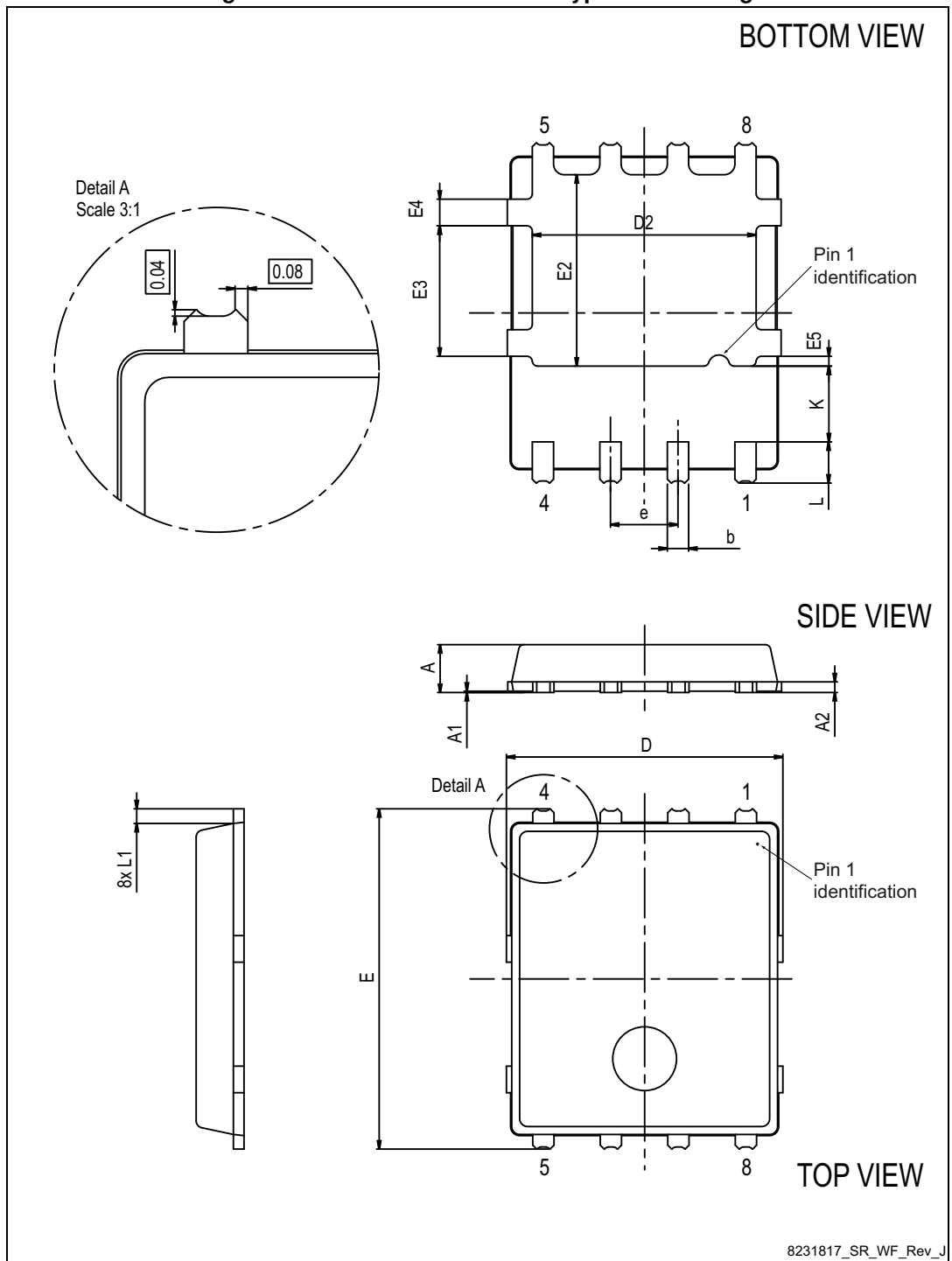
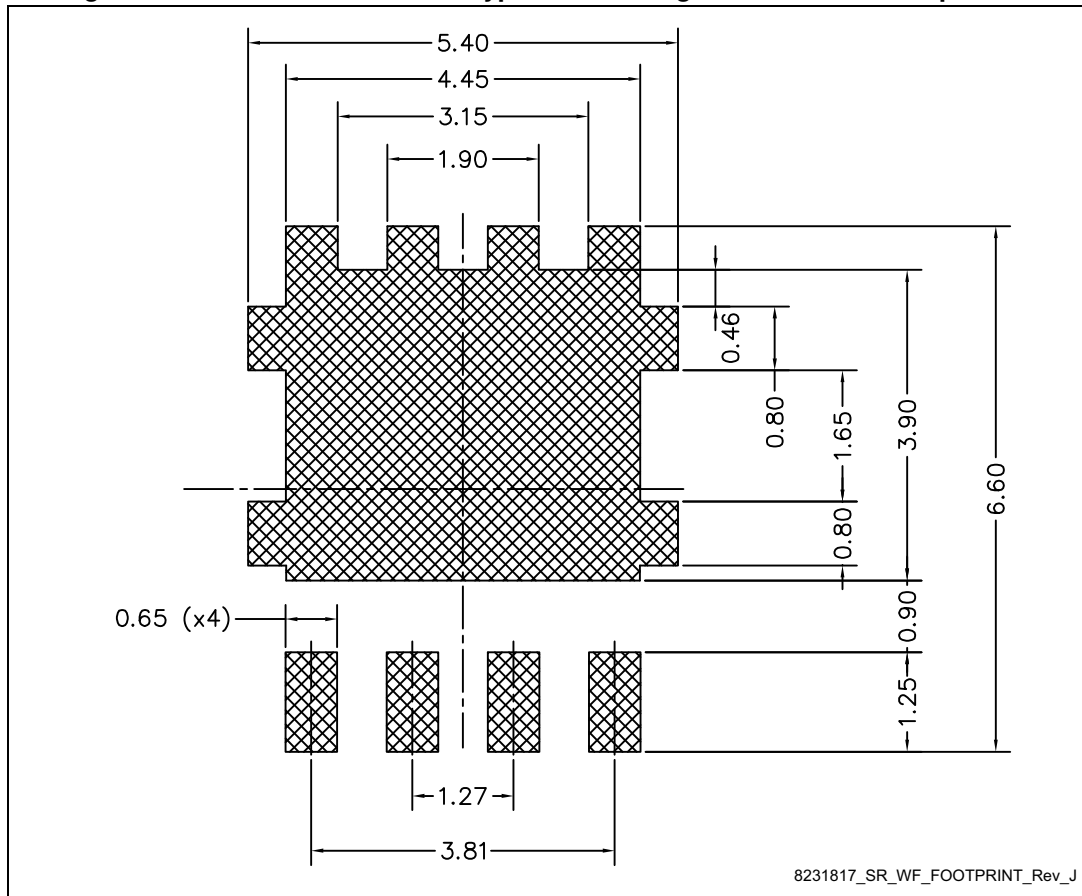

Table 8. PowerFLAT™ 5x6 WF type S-R mechanical data

Dim.	mm		
	Min.	Typ.	Max.
A	0.80		1.00
A1	0.02		0.05
A2		0.25	
b	0.30		0.50
D	5.00	5.20	5.40
E	6.20	6.40	6.60
D2	4.11		4.31
E2	3.50		3.70
e		1.27	
L	0.70		0.90
L1		0.275	
K	1.275		1.575
E3	2.35		2.55
E4	0.40		0.60
E5	0.08		0.28

Figure 20. PowerFLAT™ 5x6 WF type S-R drawing recommended footprint (a)



a. All dimensions are in mm.

## 5 Packaging mechanical data

Figure 21. PowerFLAT™ 5x6 type R-WF tape<sup>(b)</sup>

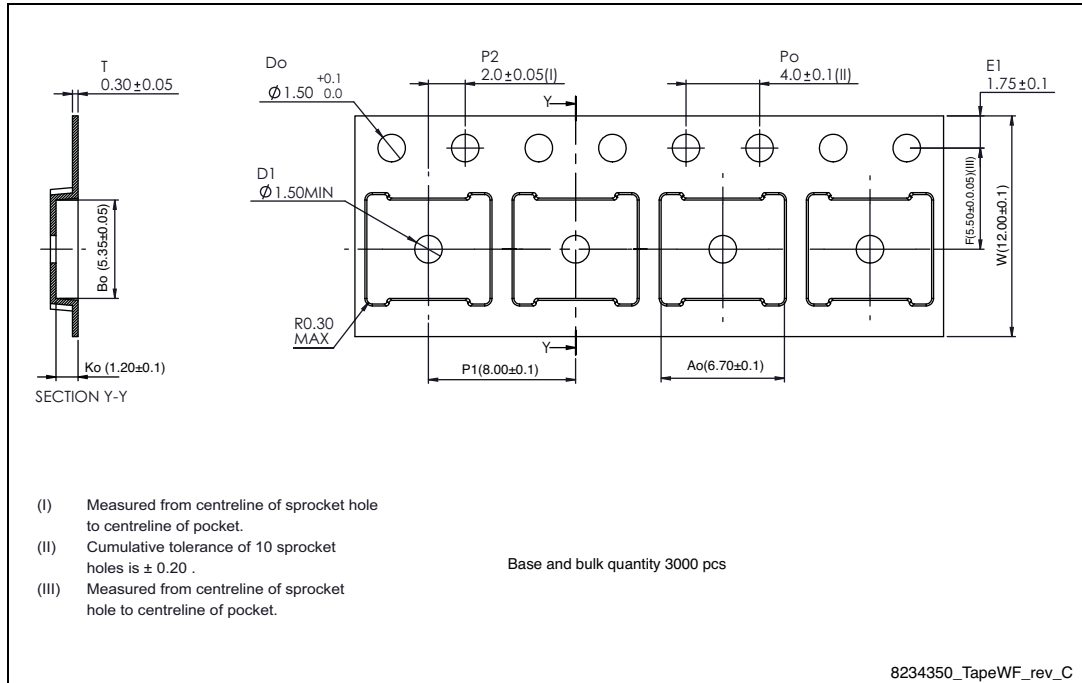
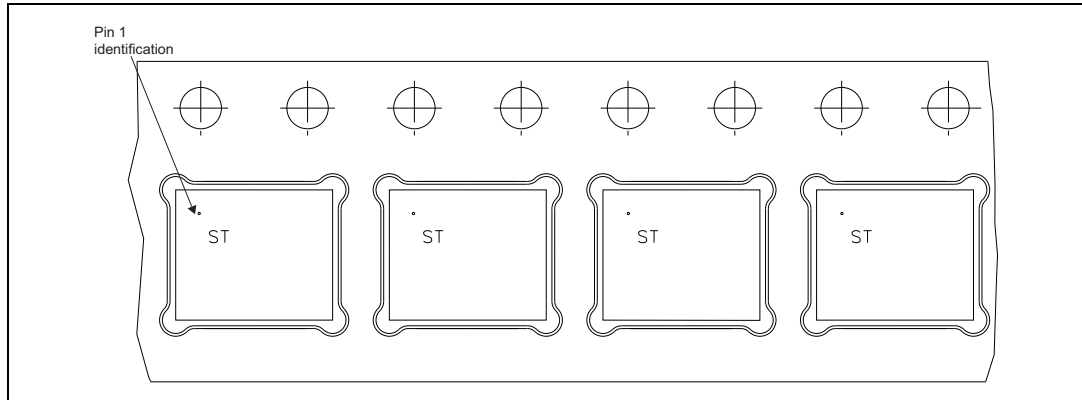
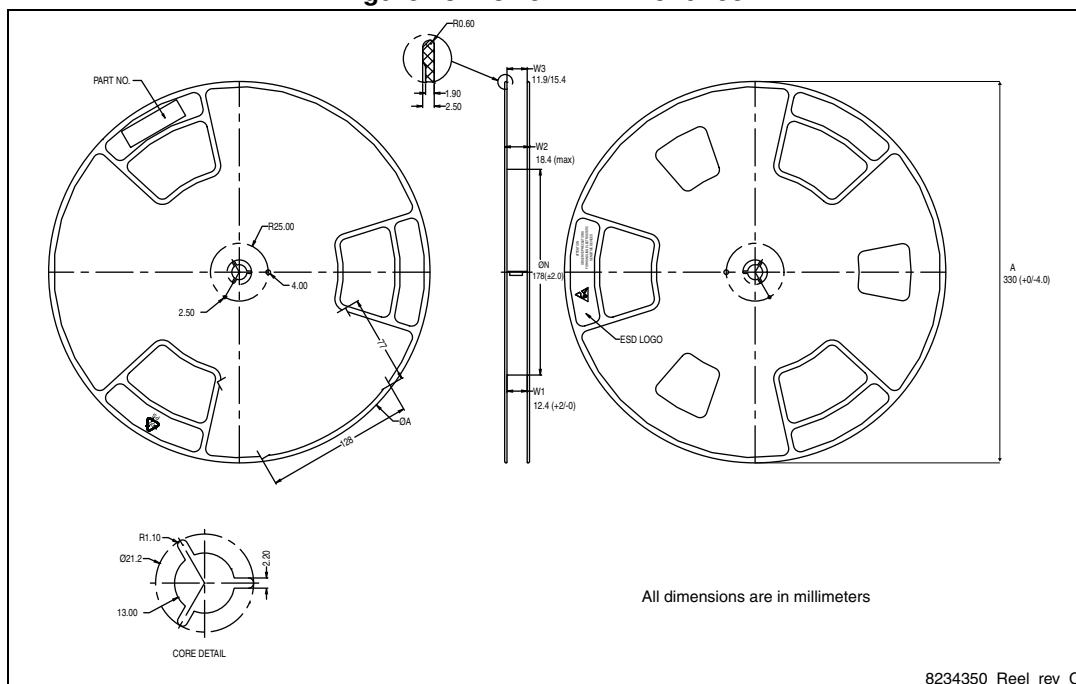

Figure 22. PowerFLAT™ 5x6 package orientation in carrier tape



b. All dimensions are in millimeters.

Figure 23. PowerFLAT™ 5x6 reel



## 6 Revision history

**Table 9. Document revision history**

Date	Revision	Changes
04-Aug-2014	1	First release.
15-Dec-2014	2	Text edits throughout document. On cover page: Updated title, features and description Updated <a href="#">Table 2: Absolute maximum ratings</a> Updated <a href="#">Figure 19: PowerFLAT™ 5x6 WF type S-R drawing</a>

**IMPORTANT NOTICE – PLEASE READ CAREFULLY**

STMicroelectronics NV and its subsidiaries ("ST") reserve the right to make changes, corrections, enhancements, modifications, and improvements to ST products and/or to this document at any time without notice. Purchasers should obtain the latest relevant information on ST products before placing orders. ST products are sold pursuant to ST's terms and conditions of sale in place at the time of order acknowledgement.

Purchasers are solely responsible for the choice, selection, and use of ST products and ST assumes no liability for application assistance or the design of Purchasers' products.

No license, express or implied, to any intellectual property right is granted by ST herein.

Resale of ST products with provisions different from the information set forth herein shall void any warranty granted by ST for such product.

ST and the ST logo are trademarks of ST. All other product or service names are the property of their respective owners.

Information in this document supersedes and replaces information previously supplied in any prior versions of this document.

© 2014 STMicroelectronics – All rights reserved