



# STD75N3LLH6, STP75N3LLH6 STU75N3LLH6, STU75N3LLH6-S

N-channel 30 V, 0.0042  $\Omega$ , 75 A, DPAK, TO-220, IPAK, Short IPAK  
STripFET™ VI DeepGATE™ Power MOSFET

## Features

Order codes	V <sub>DSS</sub>	R <sub>DS(on)</sub> max	I <sub>D</sub>
STD75N3LLH6	30 V	< 0.0055 $\Omega$	75 A
STP75N3LLH6		< 0.0059 $\Omega$	
STU75N3LLH6			
STU75N3LLH6-S			

- R<sub>DS(on)</sub> \* Q<sub>g</sub> industry benchmark
- Extremely low on-resistance R<sub>DS(on)</sub>
- High avalanche ruggedness
- Low gate drive power losses

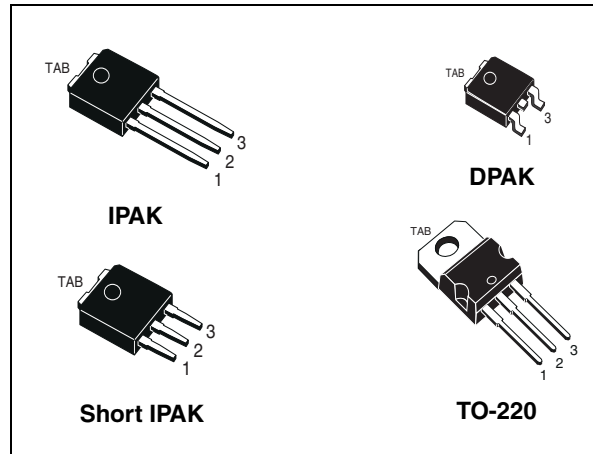

## Application

Switching applications

## Description

This N-Channel Power MOSFET product utilizes the 6<sup>th</sup> generation of design rules of ST's proprietary STripFET™ technology, with a new gate structure. The resulting Power MOSFET exhibits the lowest R<sub>DS(on)</sub> in all packages.

Figure 1. Internal schematic diagram

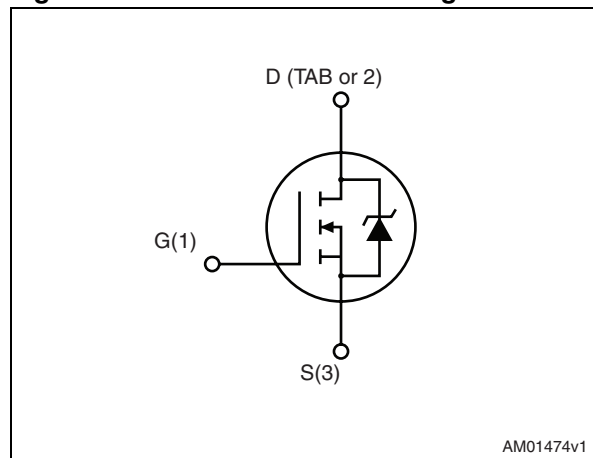

Table 1. Device summary

Order codes	Marking	Package	Packaging
STD75N3LLH6	75N3LLH6	DPAK	Tape and reel
STP75N3LLH6		TO-220	Tube
STU75N3LLH6		IPAK	
STU75N3LLH6-S		Short IPAK	

# Contents

<b>1</b>	<b>Electrical ratings</b> .....	<b>3</b>
<b>2</b>	<b>Electrical characteristics</b> .....	<b>4</b>
2.1	Electrical characteristics (curves) .....	6
<b>3</b>	<b>Test circuits</b> .....	<b>8</b>
<b>4</b>	<b>Package mechanical data</b> .....	<b>10</b>
<b>5</b>	<b>Packaging mechanical data</b> .....	<b>18</b>
<b>6</b>	<b>Revision history</b> .....	<b>20</b>

# 1 Electrical ratings

**Table 2. Absolute maximum ratings**

Symbol	Parameter	Value	Unit
$V_{DS}$	Drain-source voltage ( $V_{GS} = 0$ )	30	V
$V_{GS}$	Gate-source voltage	$\pm 20$	V
$I_D^{(1)}$	Drain current (continuous) at $T_C = 25\text{ }^\circ\text{C}$	75	A
$I_D$	Drain current (continuous) at $T_C = 70\text{ }^\circ\text{C}$	56	A
$I_D$	Drain current (continuous) at $T_C = 100\text{ }^\circ\text{C}$	47	A
$I_{DM}^{(2)}$	Drain current (pulsed)	300	A
$P_{TOT}$	Total dissipation at $T_C = 25\text{ }^\circ\text{C}$	60	W
	Derating factor	0.4	W/ $^\circ\text{C}$
$T_j$ $T_{stg}$	Operating junction temperature storage temperature	-55 to 175	$^\circ\text{C}$

1. The value is rated according to Rthj-case
2. Pulse width limited by safe operating area

**Table 3. Thermal data**

Symbol	Parameter	Value				Unit
		DKPAK	TO-220	IPAK	Short IPAK	
$R_{thj-case}$	Thermal resistance junction-case (drain) (steady state)	2.5				$^\circ\text{C}/\text{W}$
$R_{thj-amb}$	Thermal resistance junction-amb max	100	62.5	100		$^\circ\text{C}/\text{W}$
$R_{thj-pcb}^{(1)}$	Thermal resistance junction-pcb max	35				$^\circ\text{C}/\text{W}$
$T_J$	Maximum lead temperature for soldering purpose	275	300	275		$^\circ\text{C}$

1. When mounted on FR-4 board of 1in<sup>2</sup>, 2oz Cu. t < 10 sec

## 2 Electrical characteristics

( $T_{CASE}=25^{\circ}C$  unless otherwise specified)

**Table 4. On/off states**

Symbol	Parameter	Test conditions	Min.	Typ.	Max.	Unit
$V_{(BR)DSS}$	Drain-source breakdown voltage ( $V_{GS} = 0$ )	$I_D = 250 \mu A$	30			V
$I_{DSS}$	Zero gate voltage drain current ( $V_{GS} = 0$ )	$V_{DS} = 30 V$ $V_{DS} = 30 V T_C = 125^{\circ}C$			1 10	$\mu A$ $\mu A$
$I_{GSS}$	Gate-body leakage current ( $V_{DS} = 0$ )	$V_{GS} = \pm 20 V$			$\pm 100$	nA
$V_{GS(th)}$	Gate threshold voltage	$V_{DS} = V_{GS}, I_D = 250 \mu A$	1	1.7	2.5	V
$R_{DS(on)}$	Static drain-source on resistance	$V_{GS} = 10 V, I_D = 37.5 A$ SMD version		0.0042	0.0055	$\Omega$
		$V_{GS} = 10 V, I_D = 37.5 A$		0.0046	0.0059	$\Omega$
		$V_{GS} = 4.5 V, I_D = 37.5 A$ SMD version		0.0065	0.008	$\Omega$
		$V_{GS} = 4.5 V, I_D = 37.5 A$		0.0069	0.0084	$\Omega$

**Table 5. Dynamic**

Symbol	Parameter	Test conditions	Min.	Typ.	Max.	Unit
$C_{iss}$	Input capacitance	$V_{DS} = 25 V, f = 1 MHz,$ $V_{GS} = 0$	1350	1690	2030	pF
$C_{oss}$	Output capacitance		230	290	350	pF
$C_{rss}$	Reverse transfer capacitance		140	176	210	pF
$Q_g$	Total gate charge	$V_{DD} = 15 V, I_D = 75 A,$ $V_{GS} = 4.5 V$ (see <a href="#">Figure 14</a> )		17	23.8	nC
$Q_{gs}$	Gate-source charge			8	11.2	nC
$Q_{gd}$	Gate-drain charge			6	8.4	nC
$Q_{gs1}$	Pre $V_{th}$ gate-to-source charge	$V_{DD} = 15 V, I_D = 75 A$ $V_{GS} = 5 V$ ( <a href="#">Figure 19</a> )		3.9	5.5	nC
$Q_{gs2}$	Post $V_{th}$ gate-to-source charge			4.1	5.7	nC
$R_G$	Gate input resistance	f=1 MHz gate bias Bias=0 test signal level=20 mV open drain	1.25	1.7	2	$\Omega$

**Table 6. Switching times**

Symbol	Parameter	Test conditions	Min.	Typ.	Max	Unit
$t_{d(on)}$	Turn-on delay time	$V_{DD} = 15\text{ V}$ , $I_D = 37.5\text{ A}$ $R_G = 4.7\ \Omega$ , $V_{GS} = 5\text{ V}$ (see <a href="#">Figure 13</a> )	-	9.5	-	ns
$t_r$	Rise time			30		ns
$t_{d(off)}$	Turn-off delay time			37		ns
$t_f$	Fall time			12		ns

**Table 7. Source drain diode**

Symbol	Parameter	Test conditions	Min.	Typ.	Max.	Unit
$I_{SD}$	Source-drain current		-		75	A
$I_{SDM}^{(1)}$	Source-drain current (pulsed)				300	A
$V_{SD}^{(2)}$	Forward on voltage	$I_{SD} = 37.5\text{ A}$ , $V_{GS} = 0$	-		1.1	V
$t_{rr}$	Reverse recovery time	$I_{SD} = 75\text{ A}$ , $di/dt = 100\text{ A}/\mu\text{s}$ , $V_{DD} = 24\text{ V}$ (see <a href="#">Figure 15</a> )	-	24		ns
$Q_{rr}$	Reverse recovery charge			16.8		nC
$I_{RRM}$	Reverse recovery current			1.4		A

1. Pulse width limited by safe operating area.
2. Pulsed: Pulse duration = 300  $\mu\text{s}$ , duty cycle 1.5%

## 2.1 Electrical characteristics (curves)

Figure 2. Safe operating area

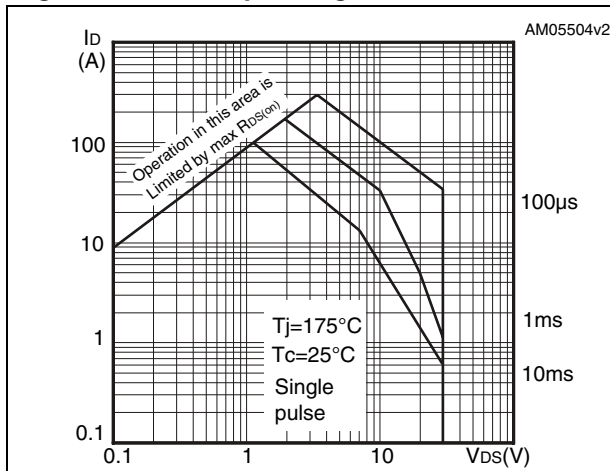

Figure 3. Thermal impedance

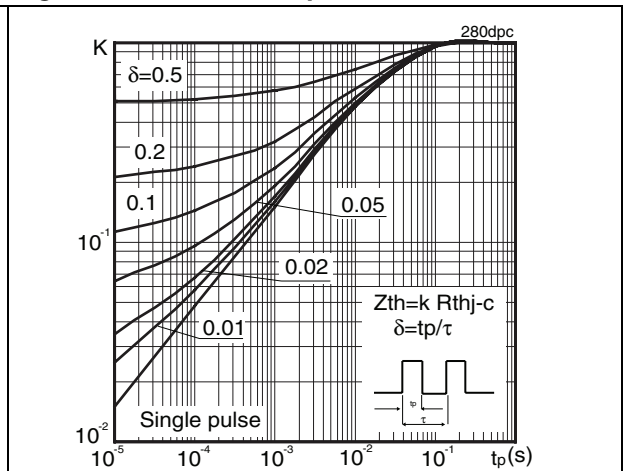

Figure 4. Output characteristics

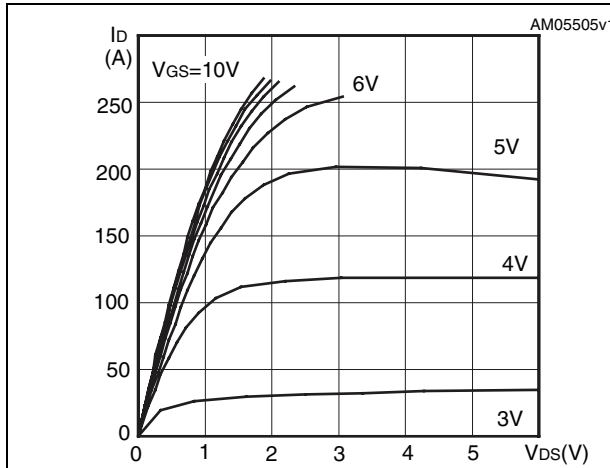

Figure 5. Transfer characteristics

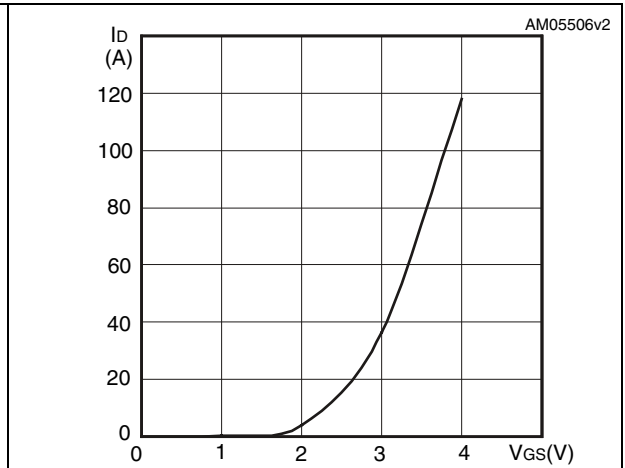

Figure 6. Normalized  $BV_{DSS}$  vs temperature

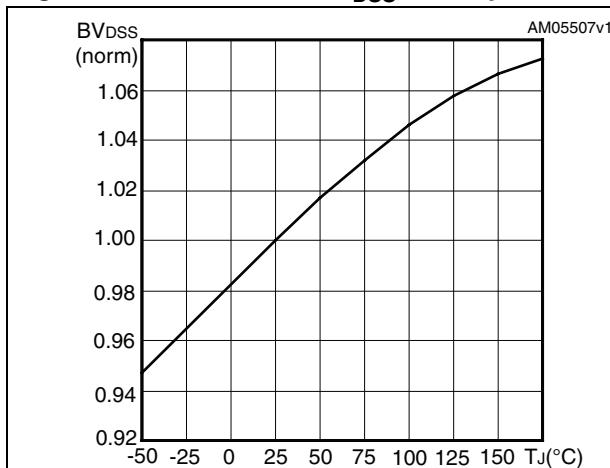

Figure 7. Static drain-source on resistance

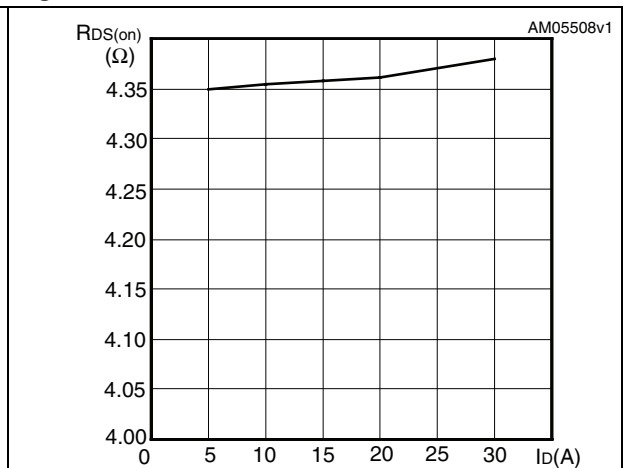

Figure 8. Gate charge vs gate-source voltage Figure 9. Capacitance variations

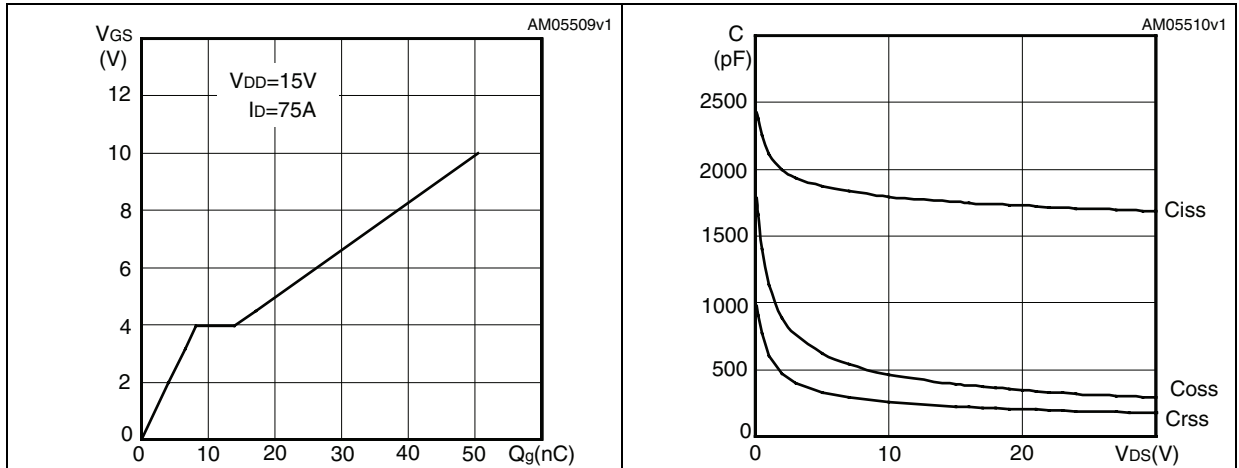

Figure 10. Normalized gate threshold voltage vs temperature Figure 11. Normalized on resistance vs temperature

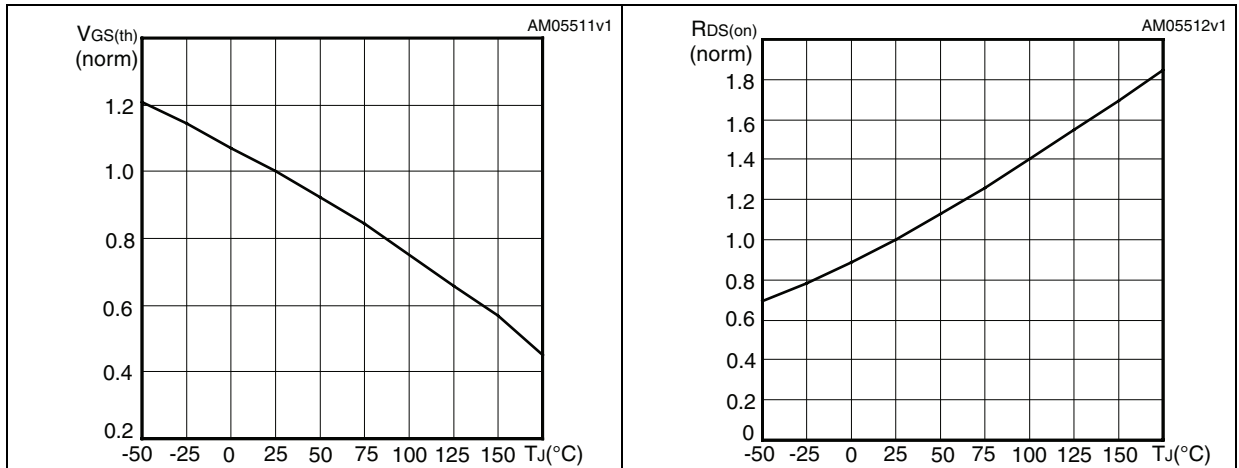
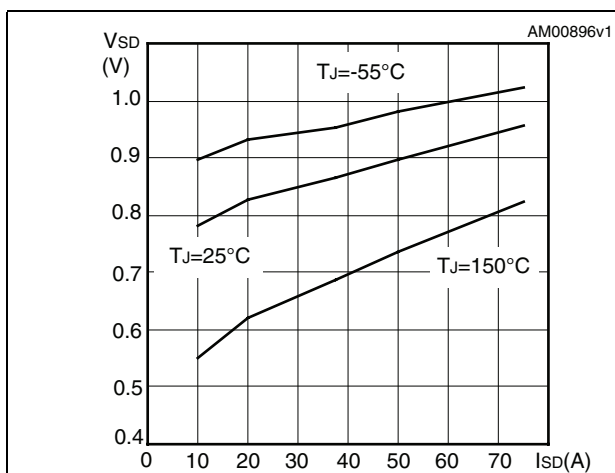
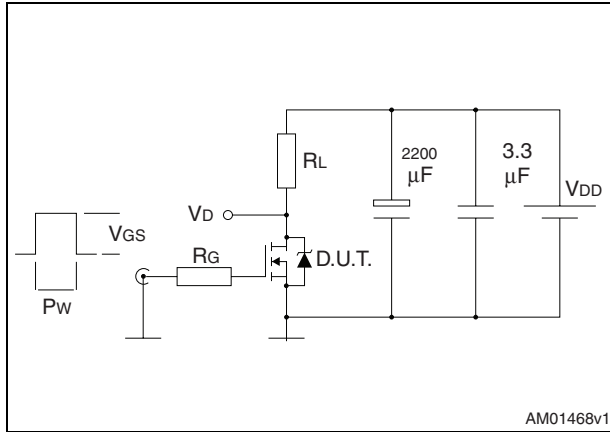

Figure 12. Source-drain diode forward characteristics



### 3 Test circuits

**Figure 13. Switching times test circuit for resistive load**



**Figure 14. Gate charge test circuit**

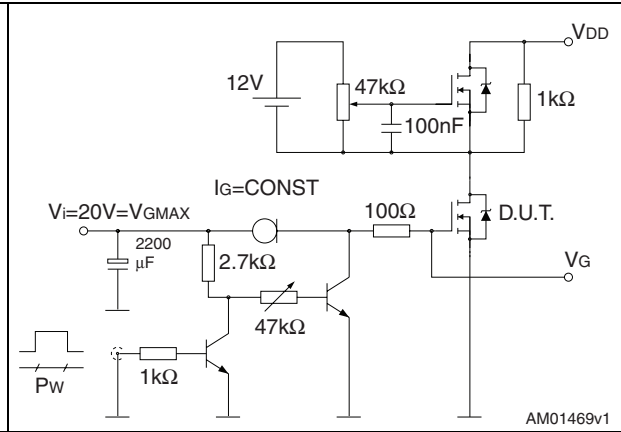

**Figure 15. Test circuit for inductive load switching and diode recovery times**

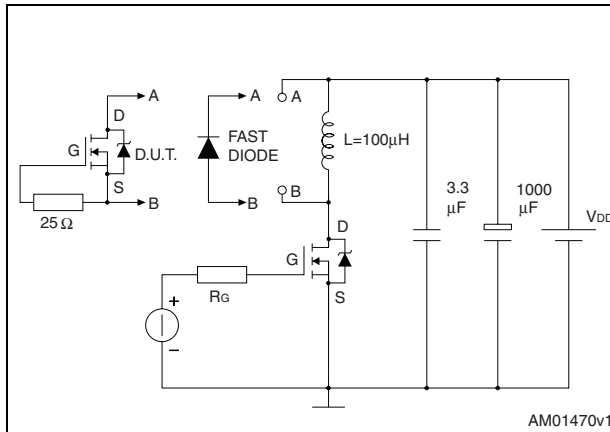

**Figure 16. Unclamped inductive load test circuit**

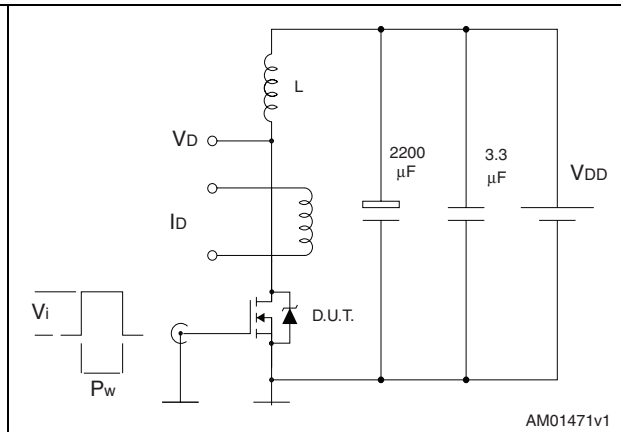

**Figure 17. Unclamped inductive waveform**

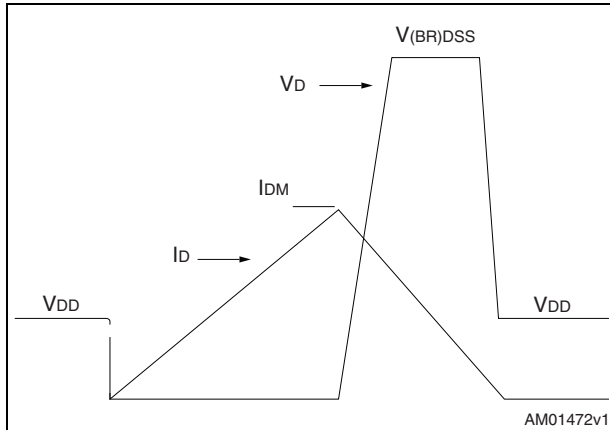

**Figure 18. Switching time waveform**

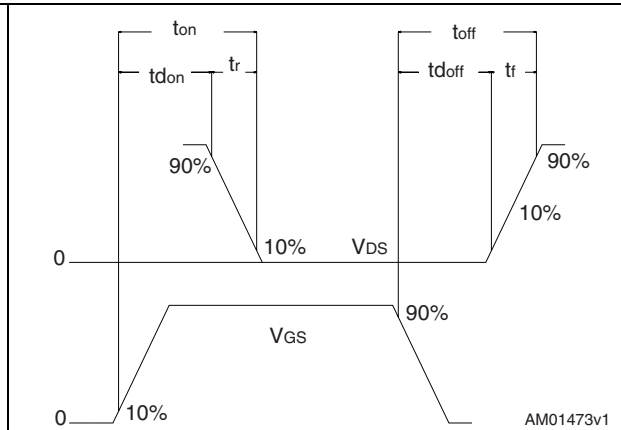
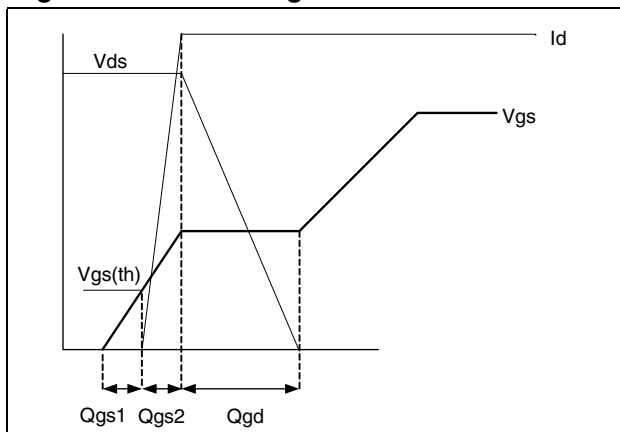



Figure 19. Gate charge waveform



## 4 Package mechanical data

In order to meet environmental requirements, ST offers these devices in different grades of ECOPACK<sup>®</sup> packages, depending on their level of environmental compliance. ECOPACK<sup>®</sup> specifications, grade definitions and product status are available at: [www.st.com](http://www.st.com). ECOPACK is an ST trademark.

Table 8. Short IPAK mechanical dimensions

Dim.	mm		
	Min	Typ	Max
A	2.20		2.40
A1	0.90		1.10
b	0.64		0.90
b2			0.95
b4	5.20		5.40
c	0.45		0.60
c2	0.48		0.60
D	6.00		6.20
E	6.40		6.60
e		2.25	
e1	4.40		4.60
H	9.80		10.40
L	3.00		3.40
L1	0.80		1.20
L2		0.80	1.00

Figure 20. Short IPAK mechanical drawing

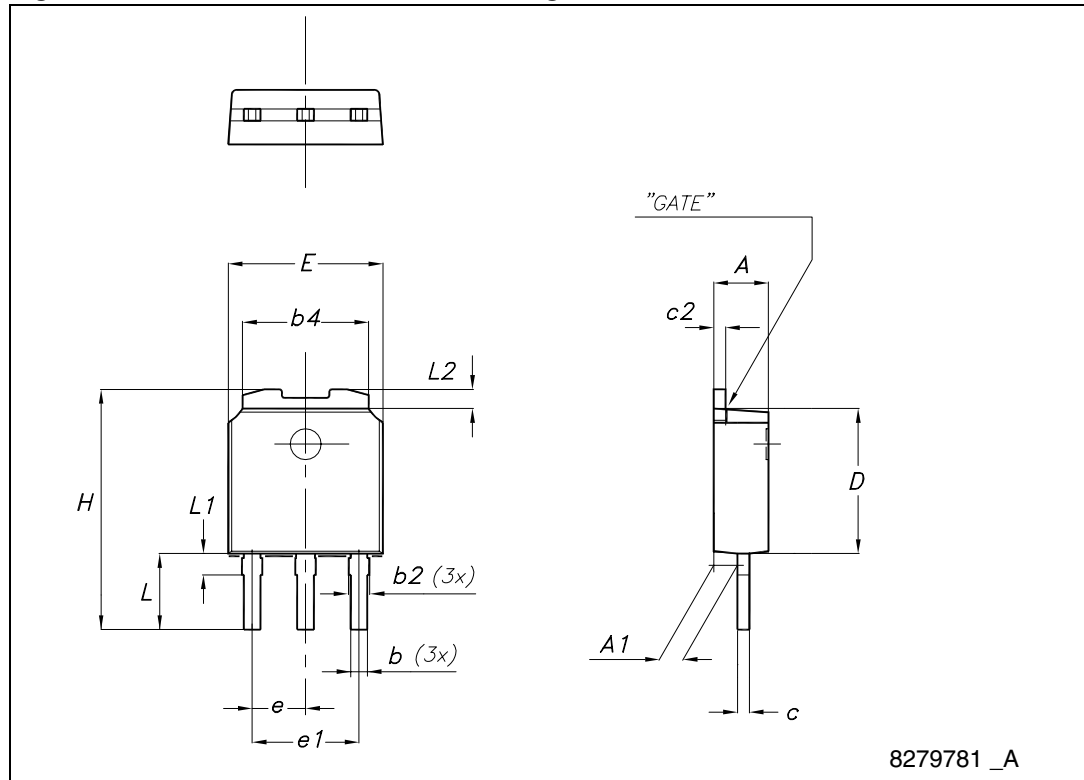
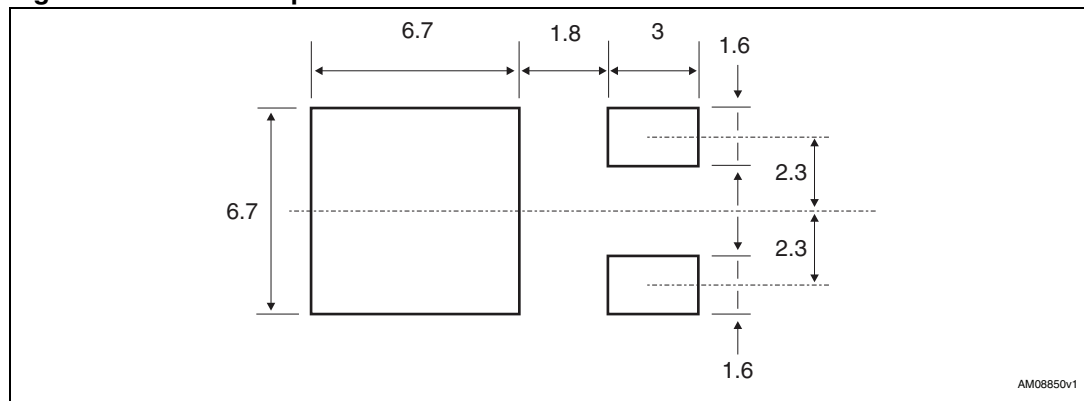

Table 9. DPAK (TO-252) mechanical data

Dim.	mm		
	Min.	Typ.	Max.
A	2.20		2.40
A1	0.90		1.10
A2	0.03		0.23
b	0.64		0.90
b4	5.20		5.40
c	0.45		0.60
c2	0.48		0.60
D	6.00		6.20
D1		5.10	
E	6.40		6.60
E1		4.70	
e		2.28	
e1	4.40		4.60
H	9.35		10.10
L	1		1.50
L1		2.80	
L2		0.80	
L4	0.60		1
R		0.20	
V2	0°		8°

Figure 21. DPAK footprint<sup>(a)</sup>



a. All dimension are in millimeters

Figure 22. DPAK (TO-252) drawing

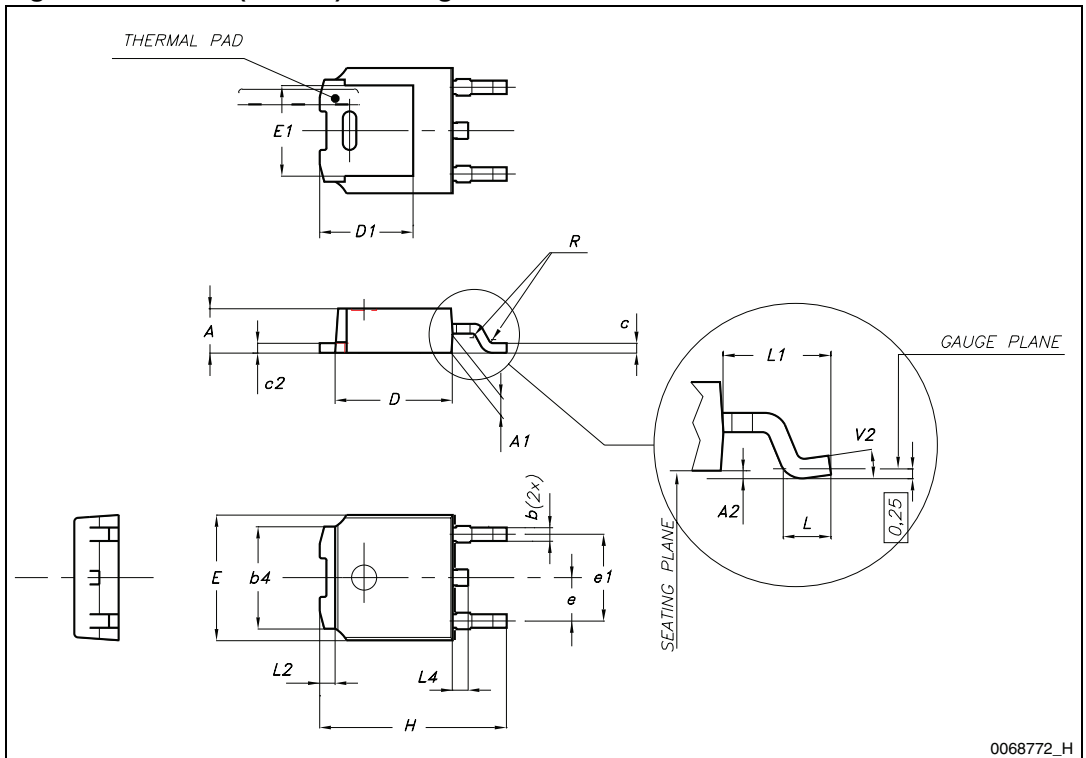

Table 10. IPAK (TO-251) mechanical data

DIM.	mm.		
	min.	typ	max.
A	2.20		2.40
A1	0.90		1.10
b	0.64		0.90
b2			0.95
b4	5.20		5.40
B5		0.3	
c	0.45		0.60
c2	0.48		0.60
D	6.00		6.20
E	6.40		6.60
e		2.28	
e1	4.40		4.60
H		16.10	
L	9.00		9.40
L1	0.80		1.20
L2		0.80	1.00
V1		10 °	

Figure 23. IPAK (TO-251) drawing

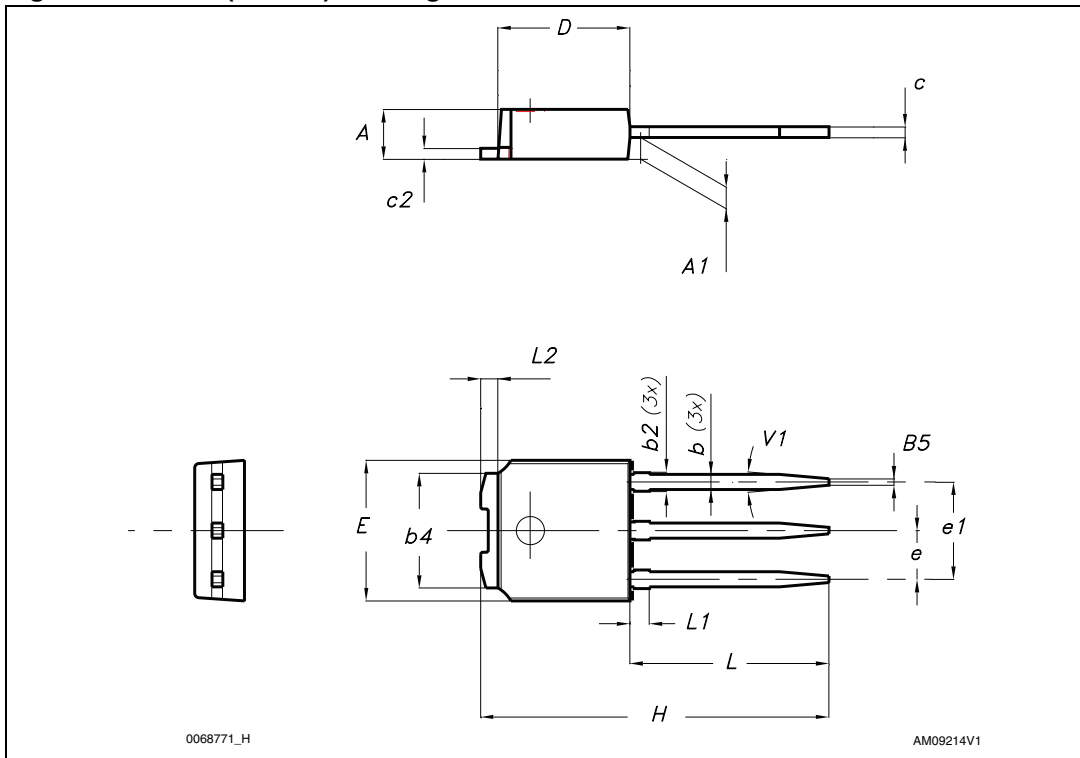
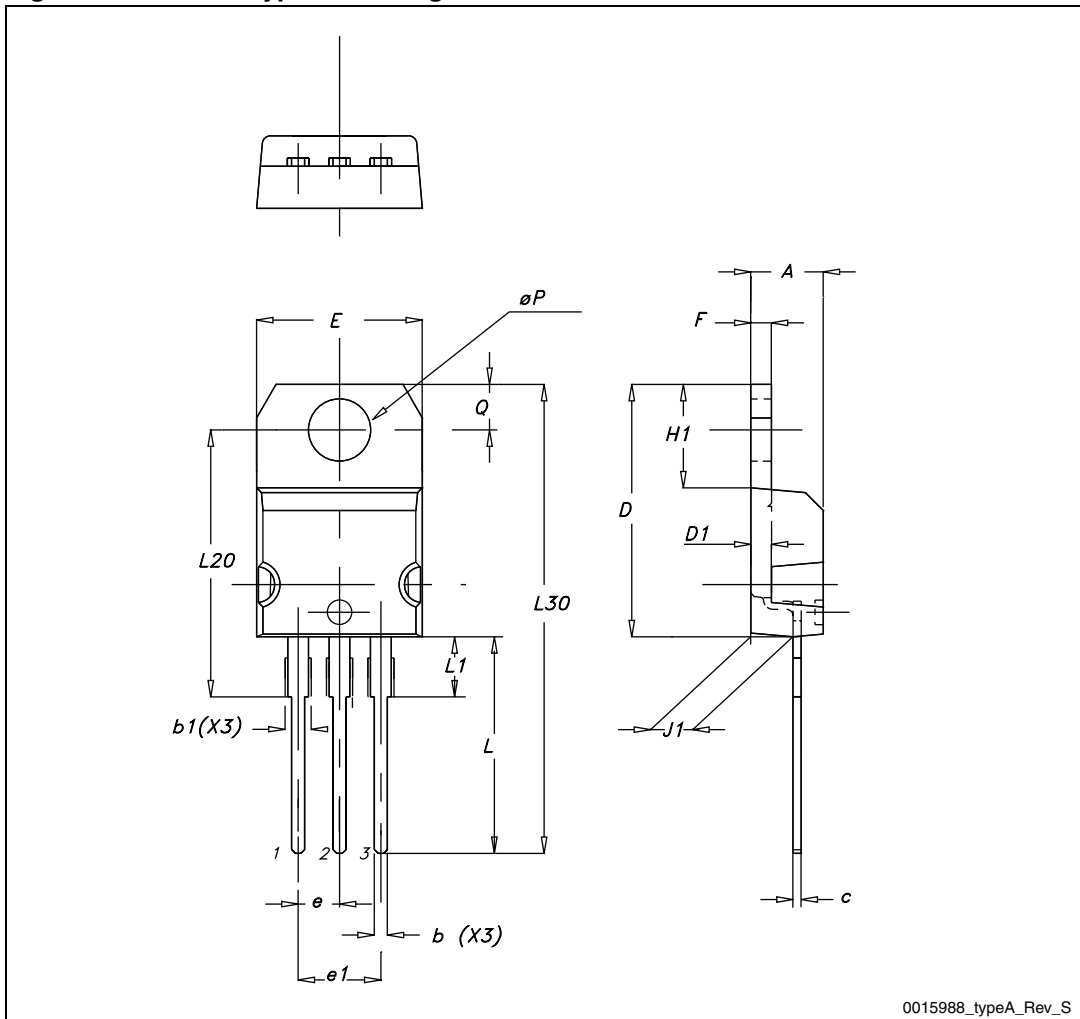

Table 11. TO-220 type A mechanical data

Dim.	mm		
	Min.	Typ.	Max.
A	4.40		4.60
b	0.61		0.88
b1	1.14		1.70
c	0.48		0.70
D	15.25		15.75
D1		1.27	
E	10		10.40
e	2.40		2.70
e1	4.95		5.15
F	1.23		1.32
H1	6.20		6.60
J1	2.40		2.72
L	13		14
L1	3.50		3.93
L20		16.40	
L30		28.90	
ØP	3.75		3.85
Q	2.65		2.95



Figure 24. TO-220 type A drawing



0015988\_typeA\_Rev\_S

## 5 Packaging mechanical data

Table 12. DPAK (TO-252) tape and reel mechanical data

Tape			Reel		
Dim.	mm		Dim.	mm	
	Min.	Max.		Min.	Max.
A0	6.8	7	A		330
B0	10.4	10.6	B	1.5	
B1		12.1	C	12.8	13.2
D	1.5	1.6	D	20.2	
D1	1.5		G	16.4	18.4
E	1.65	1.85	N	50	
F	7.4	7.6	T		22.4
K0	2.55	2.75			
P0	3.9	4.1	Base qty.		2500
P1	7.9	8.1	Bulk qty.		2500
P2	1.9	2.1			
R	40				
T	0.25	0.35			
W	15.7	16.3			

Figure 25. Tape for DPAK (TO-252)

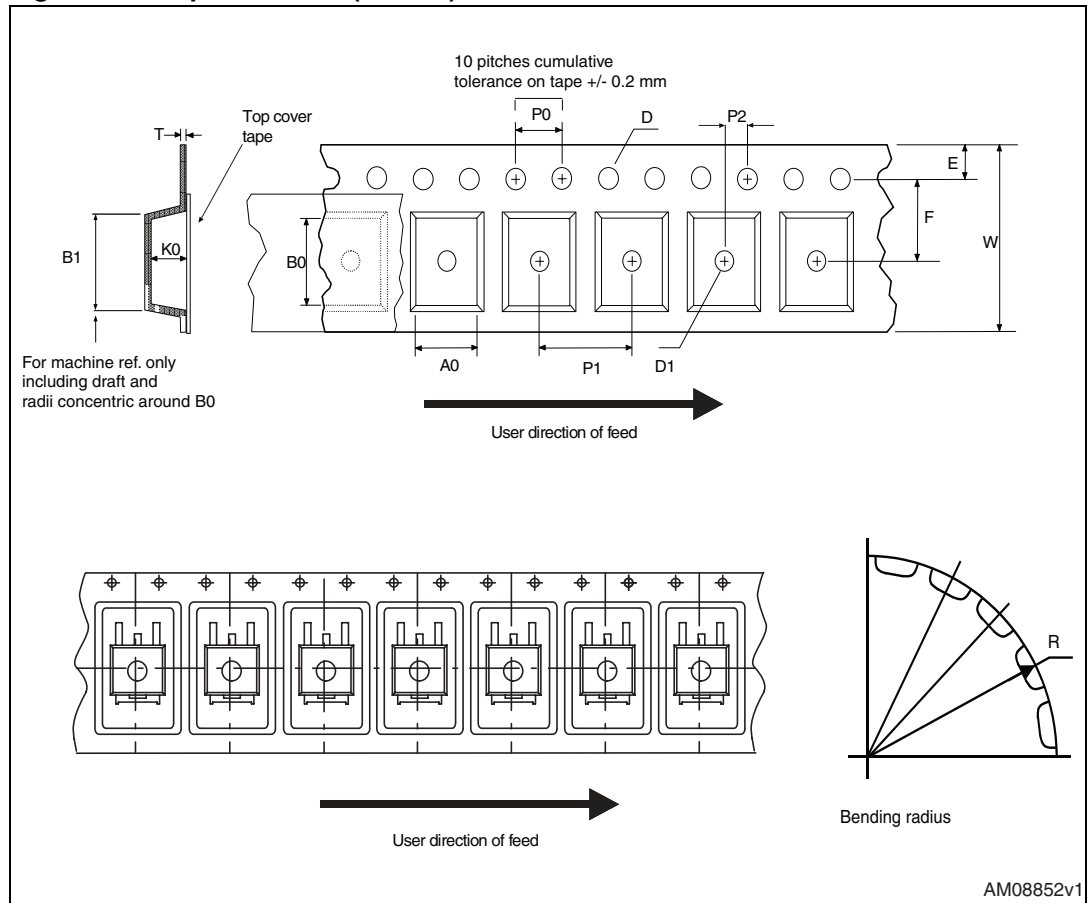
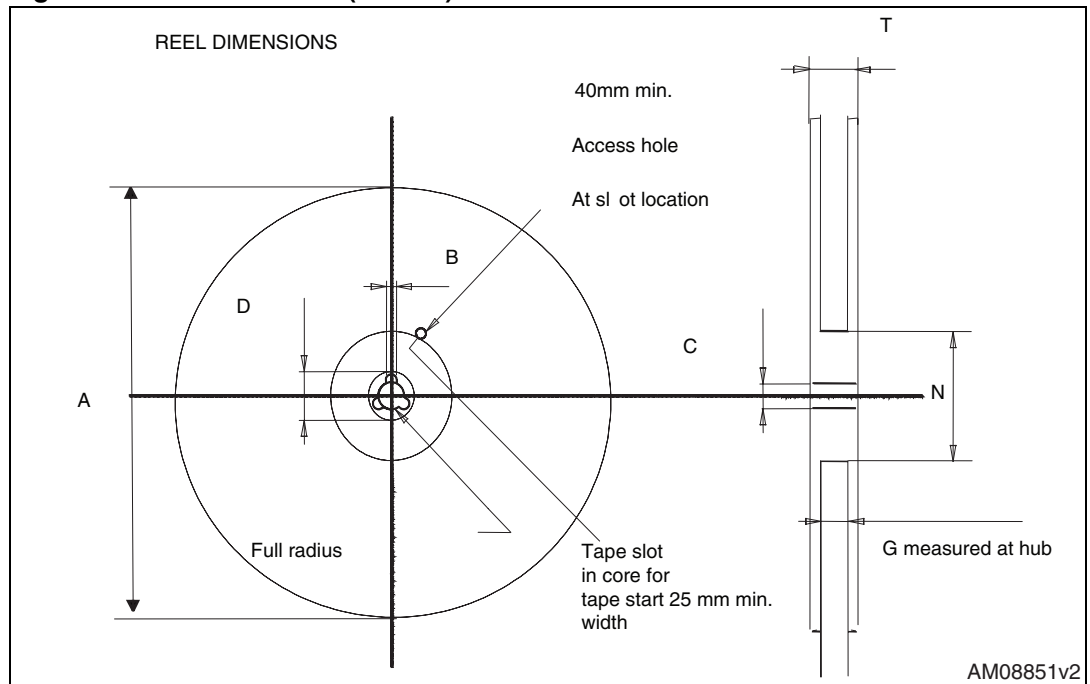

Figure 26. Reel for DPAK (TO-252)



## 6 Revision history

**Table 13. Document revision history**

Date	Revision	Changes
01-Jul-2009	1	First issue.
02-Oct-2009	2	<ul style="list-style-type: none"><li>– Added device in Short IPAK.</li><li>– Document status promoted from preliminary data to datasheet.</li></ul>
19-Apr-2011	3	<ul style="list-style-type: none"><li>– Added max values in <a href="#">Table 5: Dynamic</a>.</li><li>– Added new package and mechanical data.</li><li>– Inserted new <math>I_D</math> value @ 70 °C (see <a href="#">Table 2: Absolute maximum ratings</a>)</li></ul>
04-Jul-2011	4	Updated: mechanical data

**Please Read Carefully:**

Information in this document is provided solely in connection with ST products. STMicroelectronics NV and its subsidiaries ("ST") reserve the right to make changes, corrections, modifications or improvements, to this document, and the products and services described herein at any time, without notice.

All ST products are sold pursuant to ST's terms and conditions of sale.

Purchasers are solely responsible for the choice, selection and use of the ST products and services described herein, and ST assumes no liability whatsoever relating to the choice, selection or use of the ST products and services described herein.

No license, express or implied, by estoppel or otherwise, to any intellectual property rights is granted under this document. If any part of this document refers to any third party products or services it shall not be deemed a license grant by ST for the use of such third party products or services, or any intellectual property contained therein or considered as a warranty covering the use in any manner whatsoever of such third party products or services or any intellectual property contained therein.

**UNLESS OTHERWISE SET FORTH IN ST'S TERMS AND CONDITIONS OF SALE ST DISCLAIMS ANY EXPRESS OR IMPLIED WARRANTY WITH RESPECT TO THE USE AND/OR SALE OF ST PRODUCTS INCLUDING WITHOUT LIMITATION IMPLIED WARRANTIES OF MERCHANTABILITY, FITNESS FOR A PARTICULAR PURPOSE (AND THEIR EQUIVALENTS UNDER THE LAWS OF ANY JURISDICTION), OR INFRINGEMENT OF ANY PATENT, COPYRIGHT OR OTHER INTELLECTUAL PROPERTY RIGHT.**

**UNLESS EXPRESSLY APPROVED IN WRITING BY AN AUTHORIZED ST REPRESENTATIVE, ST PRODUCTS ARE NOT RECOMMENDED, AUTHORIZED OR WARRANTED FOR USE IN MILITARY, AIR CRAFT, SPACE, LIFE SAVING, OR LIFE SUSTAINING APPLICATIONS, NOR IN PRODUCTS OR SYSTEMS WHERE FAILURE OR MALFUNCTION MAY RESULT IN PERSONAL INJURY, DEATH, OR SEVERE PROPERTY OR ENVIRONMENTAL DAMAGE. ST PRODUCTS WHICH ARE NOT SPECIFIED AS "AUTOMOTIVE GRADE" MAY ONLY BE USED IN AUTOMOTIVE APPLICATIONS AT USER'S OWN RISK.**

Resale of ST products with provisions different from the statements and/or technical features set forth in this document shall immediately void any warranty granted by ST for the ST product or service described herein and shall not create or extend in any manner whatsoever, any liability of ST.

ST and the ST logo are trademarks or registered trademarks of ST in various countries.

Information in this document supersedes and replaces all information previously supplied.

The ST logo is a registered trademark of STMicroelectronics. All other names are the property of their respective owners.

© 2011 STMicroelectronics - All rights reserved

STMicroelectronics group of companies

Australia - Belgium - Brazil - Canada - China - Czech Republic - Finland - France - Germany - Hong Kong - India - Israel - Italy - Japan - Malaysia - Malta - Morocco - Philippines - Singapore - Spain - Sweden - Switzerland - United Kingdom - United States of America

[www.st.com](http://www.st.com)