

STB28N65M2, STF28N65M2, STP28N65M2, STW28N65M2

N-channel 650 V, 0.15 Ω typ., 20 A MDmesh™ M2 Power MOSFETs
in D²PAK, TO-220FP, TO-220 and TO-247 packages

Datasheet - preliminary data

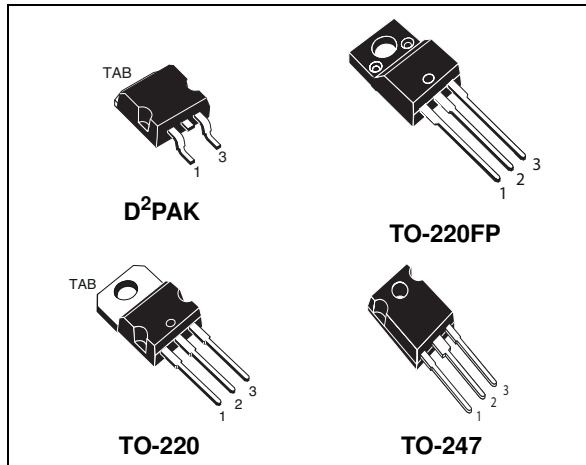
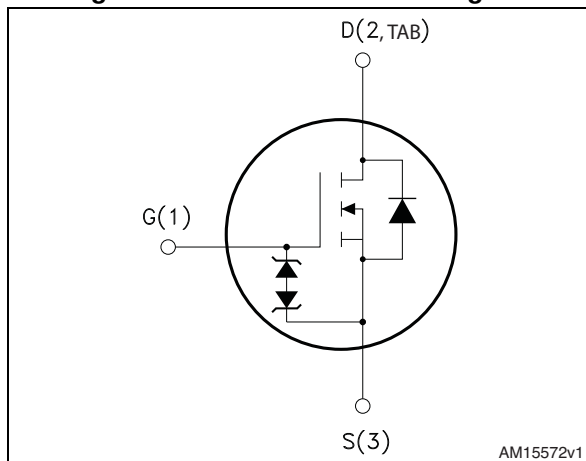

Figure 1. Internal schematic diagram



Features

| Order codes | V _{DS} | R _{DS(on)} max | I _D |
|-------------|-----------------|-------------------------|----------------|
| STB28N65M2 | 650 V | 0.18 Ω | 20 A |
| STF28N65M2 | | | |
| STP28N65M2 | | | |
| STW28N65M2 | | | |

- Extremely low gate charge
- Excellent output capacitance (C_{oss}) profile
- 100% avalanche tested
- Zener-protected

Applications

- Switching applications

Description

These devices are N-channel Power MOSFETs developed using MDmesh™ M2 technology. Thanks to their strip layout and improved vertical structure, the devices exhibit low on-resistance and optimized switching characteristics, rendering them suitable for the most demanding high efficiency converters.

Table 1. Device summary

| Order codes | Marking | Package | Packaging |
|-------------|---------|--------------------|---------------|
| STB28N65M2 | 28N65M2 | D ² PAK | Tape and reel |
| STF28N65M2 | | TO-220FP | Tube |
| STP28N65M2 | | TO-220 | |
| STW28N65M2 | | TO-247 | |

Contents

- 1 Electrical ratings 3**
- 2 Electrical characteristics 4**
 - 2.1 Electrical characteristics (curves) 6
- 3 Test circuits 9**
- 4 Package mechanical data 10**
 - 4.1 D²PAK, STB28N65M2 10
 - 4.2 TO-220FP, STF28N65M2 13
 - 4.3 TO-220, STP28N65M2 15
 - 4.4 TO-247, STW28N65M2 17
- 5 Packing mechanical data 19**
- 6 Revision history 21**

1 Electrical ratings

Table 2. Absolute maximum ratings

| Symbol | Parameter | Value | | Unit |
|--------------------------------|---|---------------------------------------|-------------------|------|
| | | D ² PAK, TO-220, TO-247 | TO-220FP | |
| V _{GS} | Gate-source voltage | ± 25 | | V |
| I _D | Drain current (continuous) at T _C = 25 °C | 20 | 20 ⁽¹⁾ | A |
| I _D | Drain current (continuous) at T _C = 100 °C | 13 | 13 ⁽¹⁾ | A |
| I _{DM} ⁽²⁾ | Drain current (pulsed) | 80 | | A |
| P _{TOT} | Total dissipation at T _C = 25 °C | 170 | 30 | W |
| V _{ISO} | Insulation withstand voltage (RMS) from all three leads to external heat sink (t = 1 s; T _C = 25 °C) | | 2500 | V |
| dv/dt ⁽³⁾ | Peak diode recovery voltage slope | 15 | | V/ns |
| dv/dt ⁽⁴⁾ | MOSFET dv/dt ruggedness | 50 | | |
| T _{stg} | Storage temperature | - 55 to 150 | | °C |
| T _j | Max. operating junction temperature | 150 | | |

1. Current limited by package.
2. Pulse width limited by safe operating area.
3. I_{SD} ≤ 20 A, di/dt ≤ 400 A/μs; V_{DS peak} < V_{(BR)DSS}; V_{DD}=520 V
4. V_{DS} ≤ 520 V

Table 3. Thermal data

| Symbol | Parameter | Value | | | | Unit |
|-------------------------------------|---|--------------------|----------|--------|--------|------|
| | | D ² PAK | TO-220FP | TO-220 | TO-247 | |
| R _{thj-case} | Thermal resistance junction-case max | 0.74 | 4.17 | 0.74 | | °C/W |
| R _{thj-pcb} ⁽¹⁾ | Thermal resistance junction-pcb max | 30 | | | | °C/W |
| R _{thj-amb} | Thermal resistance junction-ambient max | | 62.5 | | 50 | °C/W |

1. When mounted on 1 inch² FR-4, 2 Oz copper board

Table 4. Avalanche characteristics

| Symbol | Parameter | Value | Unit |
|-----------------|---|-------|------|
| I _{AR} | Avalanche current, repetitive or not repetitive (pulse width limited by T _{jmax}) | 2.4 | A |
| E _{AS} | Single pulse avalanche energy (starting T _j = 25°C, I _D = I _{AR} ; V _{DD} = 50 V) | 760 | mJ |

2 Electrical characteristics

($T_C = 25\text{ °C}$ unless otherwise specified)

Table 5. On /off states

| Symbol | Parameter | Test conditions | Min. | Typ. | Max. | Unit |
|---------------|-----------------------------------|--|------|------|----------|---------------|
| $V_{(BR)DSS}$ | Drain-source breakdown voltage | $V_{GS} = 0, I_D = 1\text{ mA}$ | 650 | | | V |
| I_{DSS} | Zero gate voltage drain current | $V_{GS} = 0, V_{DS} = 650\text{ V}$ | | | 1 | μA |
| | | $V_{GS} = 0, V_{DS} = 650\text{ V}$ $T_C = 125\text{ °C}$ | | | 100 | μA |
| I_{GSS} | Gate-body leakage current | $V_{DS} = 0, V_{GS} = \pm 25\text{ V}$ | | | ± 10 | μA |
| $V_{GS(th)}$ | Gate threshold voltage | $V_{DS} = V_{GS}, I_D = 250\text{ }\mu\text{A}$ | 2 | 3 | 4 | V |
| $R_{DS(on)}$ | Static drain-source on-resistance | $V_{GS} = 10\text{ V}, I_D = 10\text{ A}$ | | 0.15 | 0.18 | Ω |

Table 6. Dynamic

| Symbol | Parameter | Test conditions | Min. | Typ. | Max. | Unit |
|---------------------------|-------------------------------|---|------|------|------|----------|
| C_{iss} | Input capacitance | $V_{DS} = 100\text{ V}, f = 1\text{ MHz},$ $V_{GS} = 0$ | - | 1440 | - | pF |
| C_{oss} | Output capacitance | | - | 60 | - | pF |
| C_{rss} | Reverse transfer capacitance | | - | 2 | - | pF |
| $C_{oss\text{ eq}}^{(1)}$ | Equivalent output capacitance | $V_{GS} = 0, V_{DS} = 0\text{ to }520\text{ V}$ | - | 307 | - | pF |
| R_G | Intrinsic gate resistance | $f = 1\text{ MHz open drain}$ | - | 4.9 | - | Ω |
| Q_g | Total gate charge | $V_{DD} = 520\text{ V}, I_D = 20\text{ A},$ $V_{GS} = 10\text{ V}$ (see Figure 19) | - | 35 | - | nC |
| Q_{gs} | Gate-source charge | | - | 6 | - | nC |
| Q_{gd} | Gate-drain charge | | - | 15 | - | nC |

1. $C_{oss\text{ eq}}$ is defined as a constant equivalent capacitance giving the same charging time as C_{oss} when V_{DS} increases from 0 to 80% V_{DSS}

Table 7. Switching times

| Symbol | Parameter | Test conditions | Min. | Typ. | Max. | Unit |
|--------------|---------------------|--|------|------|------|------|
| $t_{d(on)}$ | Turn-on delay time | $V_{DD} = 325\text{ V}, I_D = 10\text{ A},$ $R_G = 4.7\text{ }\Omega, V_{GS} = 10\text{ V}$ (see Figure 18 and Figure 23) | - | 13.4 | - | ns |
| t_r | Rise time | | - | 10 | - | ns |
| $t_{d(off)}$ | Turn-off delay time | | - | 59 | - | ns |
| t_f | Fall time | | - | 8.8 | - | ns |

Table 8. Source drain diode

| Symbol | Parameter | Test conditions | Min. | Typ. | Max. | Unit |
|-----------------|-------------------------------|---|------|------|------|---------------|
| I_{SD} | Source-drain current | | - | | 20 | A |
| $I_{SDM}^{(1)}$ | Source-drain current (pulsed) | | - | | 80 | A |
| $V_{SD}^{(2)}$ | Forward on voltage | $V_{GS} = 0, I_{SD} = 20 \text{ A}$ | - | | 1.6 | V |
| t_{rr} | Reverse recovery time | $I_{SD} = 20 \text{ A}, di/dt = 100 \text{ A}/\mu\text{s}$ $V_{DD} = 60 \text{ V}$ (see Figure 20) | - | 384 | | ns |
| Q_{rr} | Reverse recovery charge | | - | 5.7 | | μC |
| I_{RRM} | Reverse recovery current | | - | 30 | | A |
| t_{rr} | Reverse recovery time | $I_{SD} = 20 \text{ A}, di/dt = 100 \text{ A}/\mu\text{s}$ $V_{DD} = 60 \text{ V}, T_j = 150 \text{ }^\circ\text{C}$ (see Figure 20) | - | 544 | | ns |
| Q_{rr} | Reverse recovery charge | | - | 8.2 | | μC |
| I_{RRM} | Reverse recovery current | | - | 30.5 | | A |

1. Pulse width limited by safe operating area.
2. Pulsed: pulse duration = 300 μs , duty cycle 1.5%

2.1 Electrical characteristics (curves)

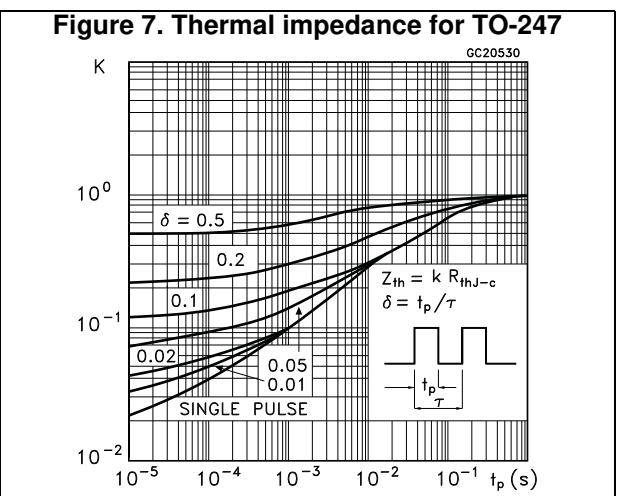
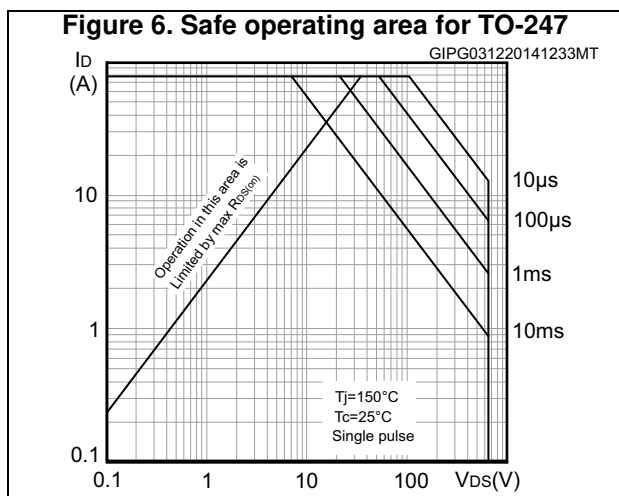
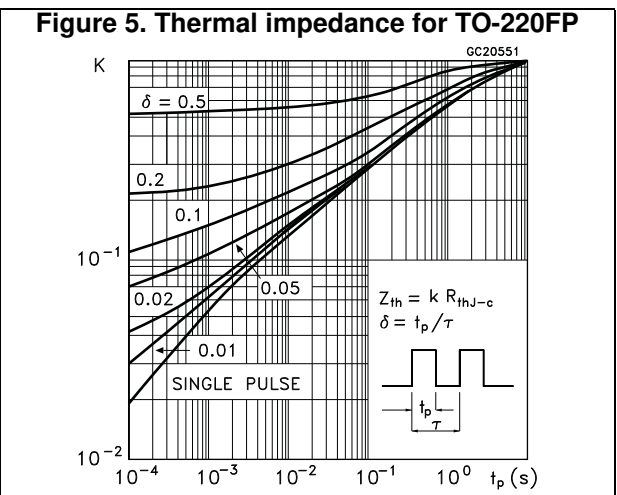
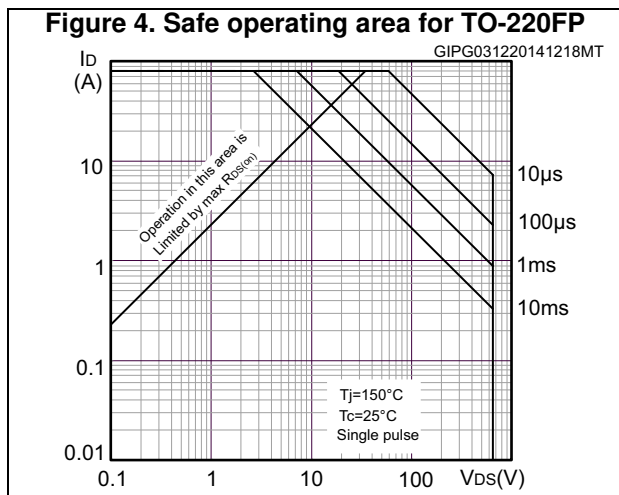
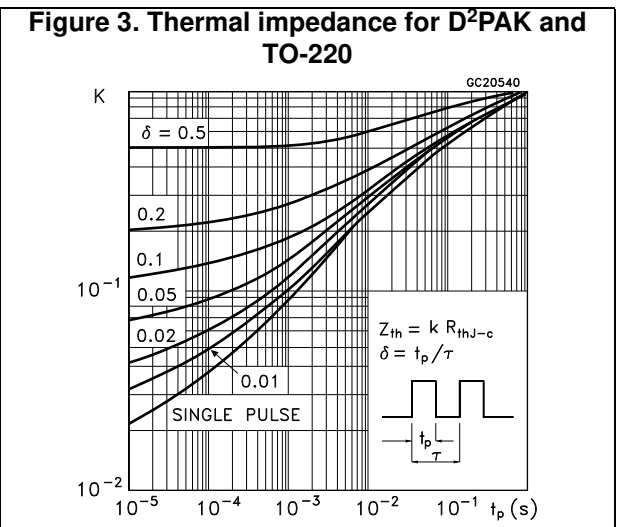
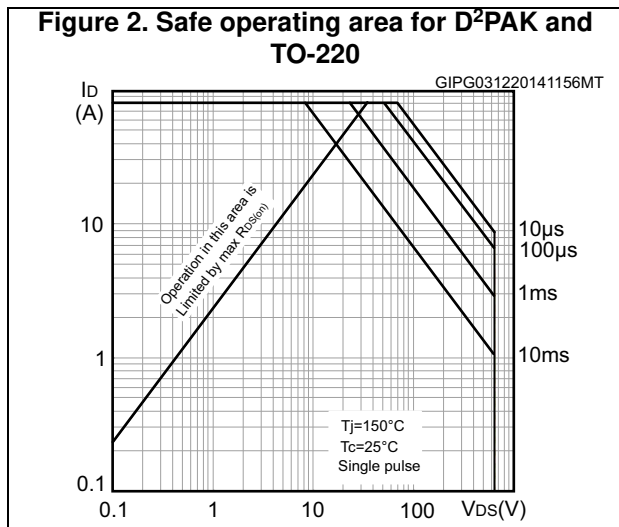

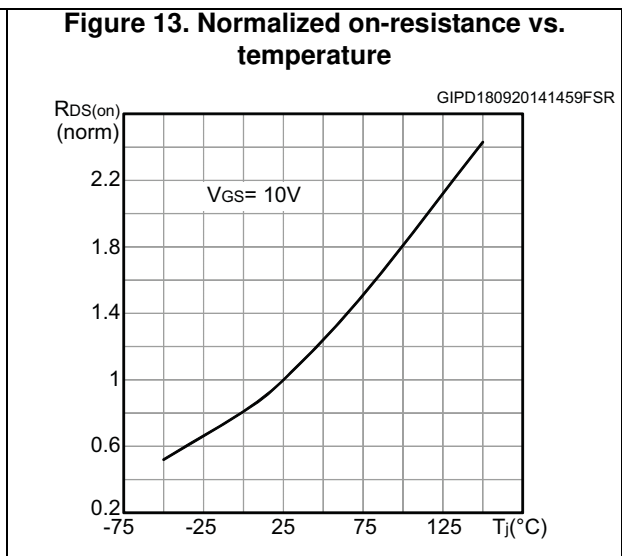
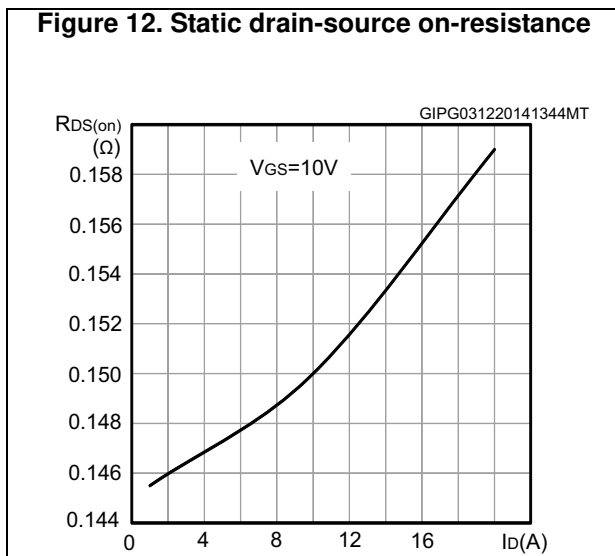
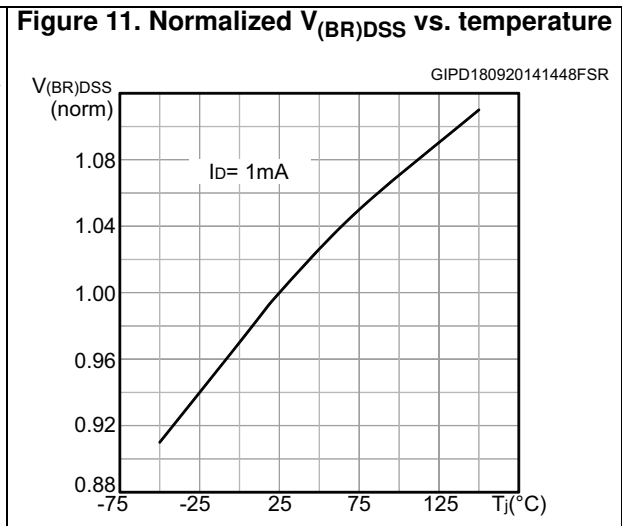
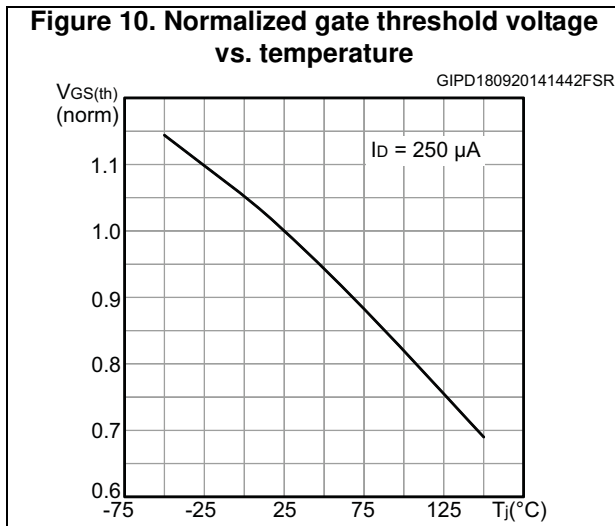
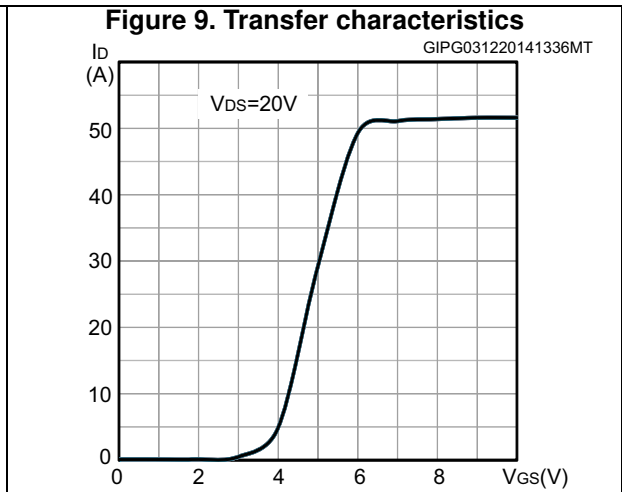
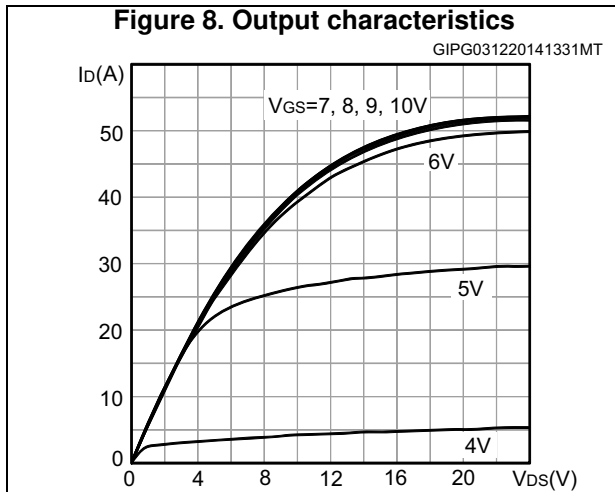

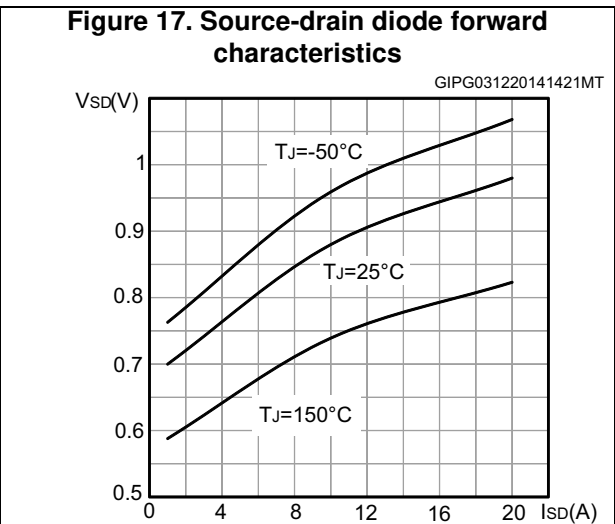
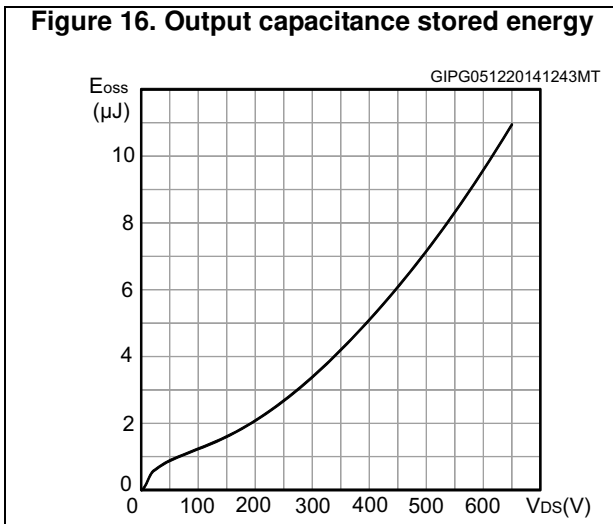
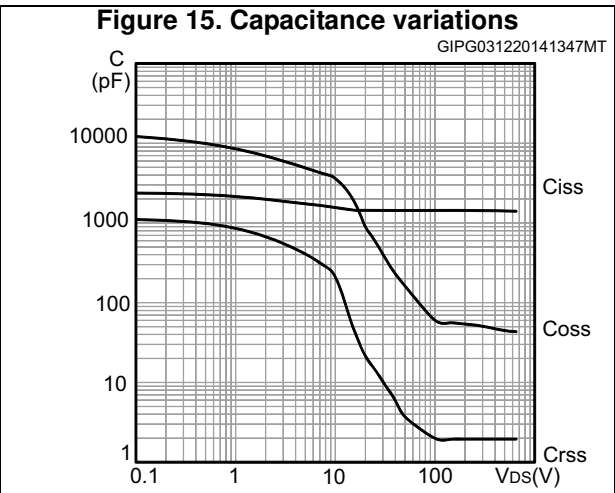
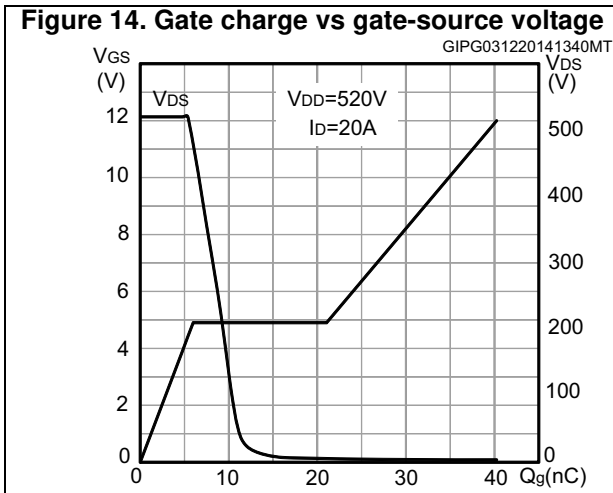

3 Test circuits

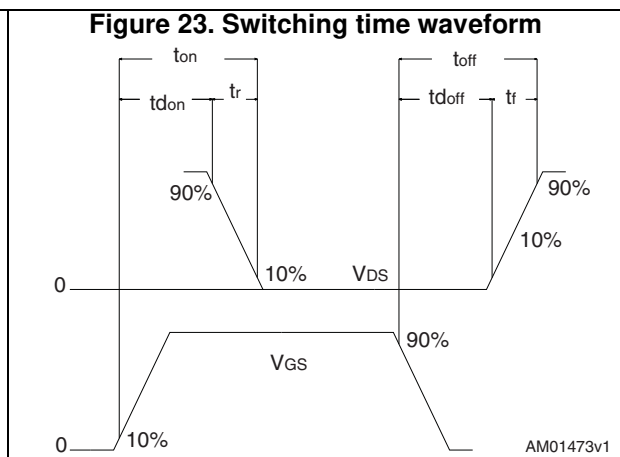
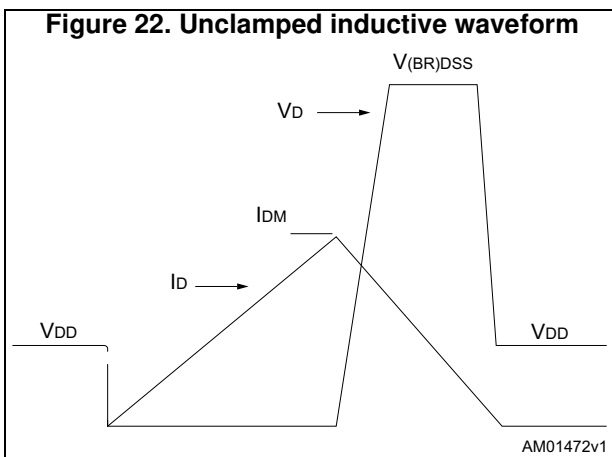
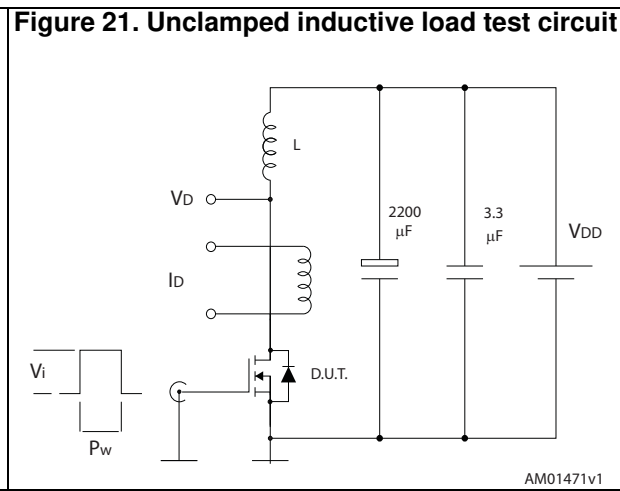
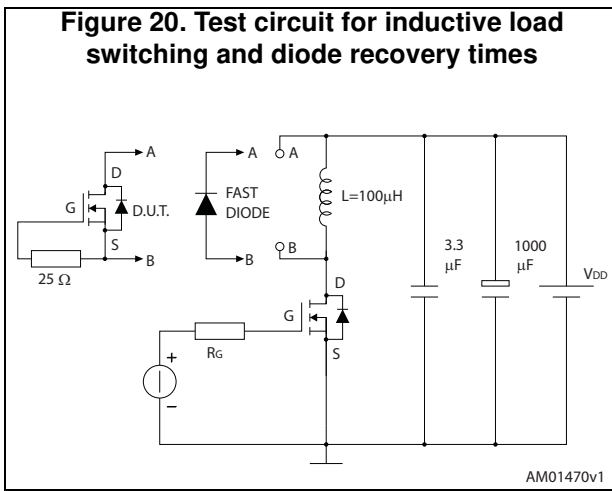
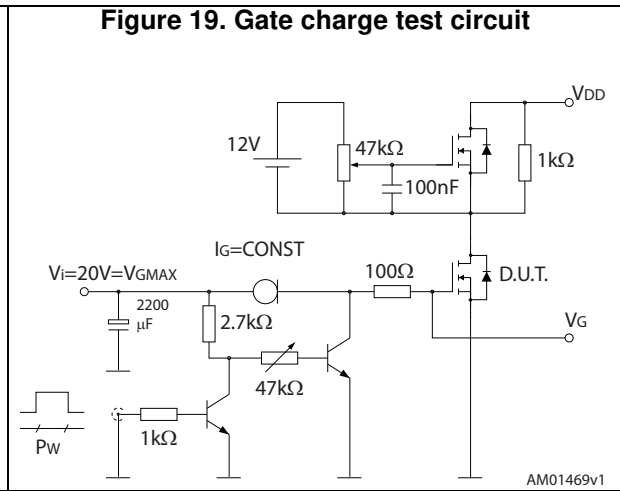
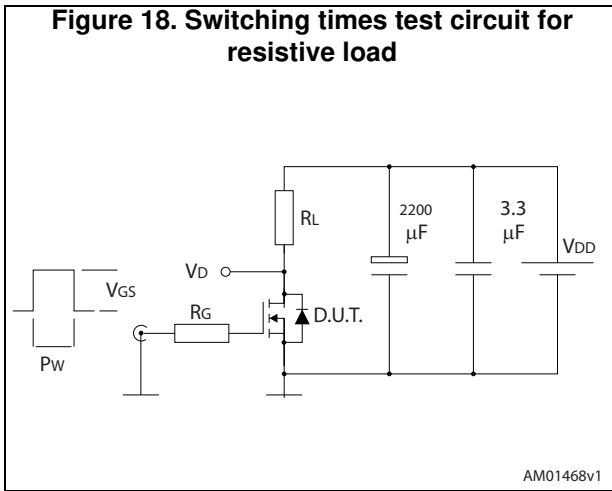

4 Package mechanical data

In order to meet environmental requirements, ST offers these devices in different grades of ECOPACK® packages, depending on their level of environmental compliance. ECOPACK® specifications, grade definitions and product status are available at: www.st.com. ECOPACK® is an ST trademark.

4.1 D²PAK, STB28N65M2

Figure 24. D²PAK drawing

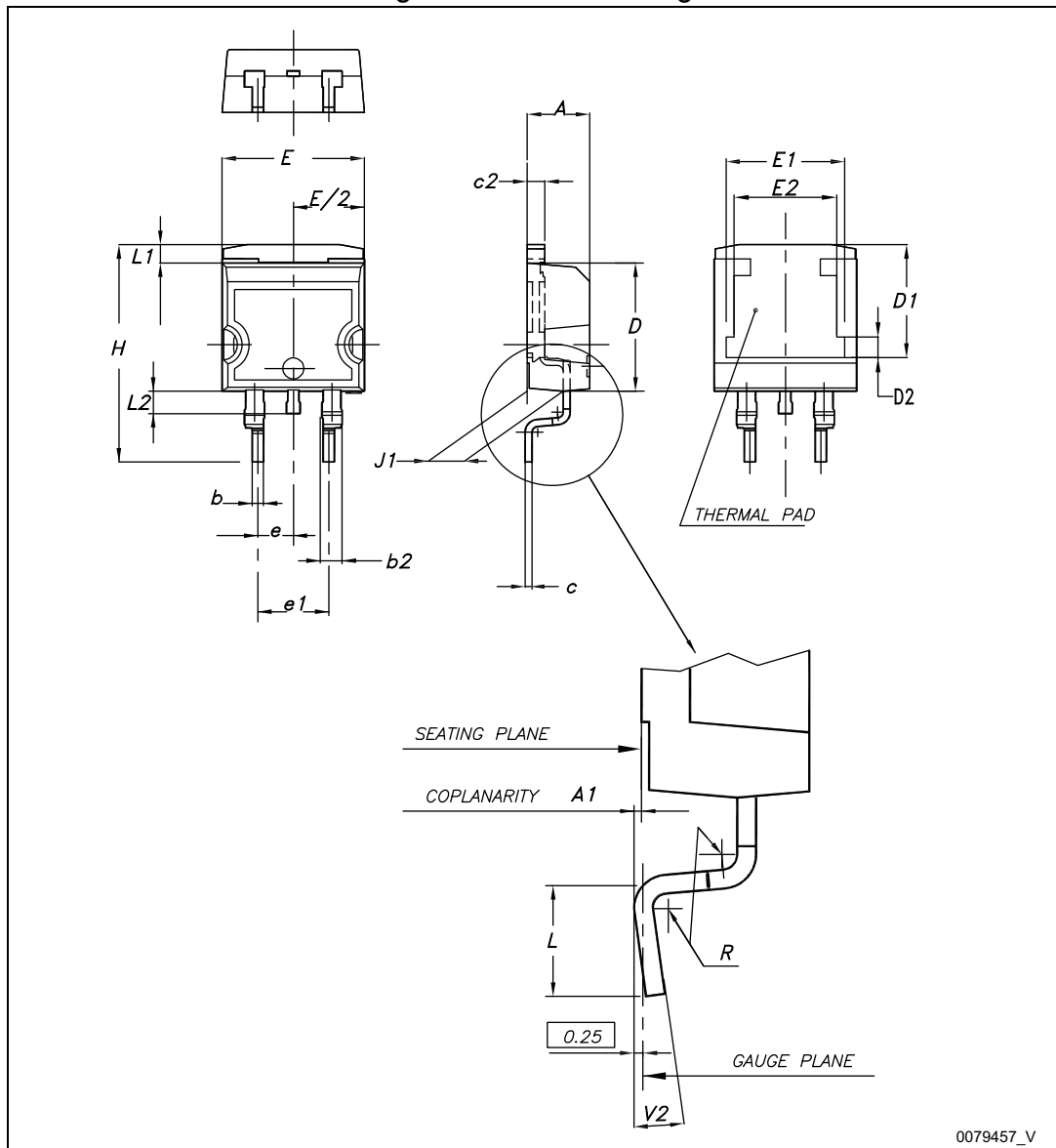
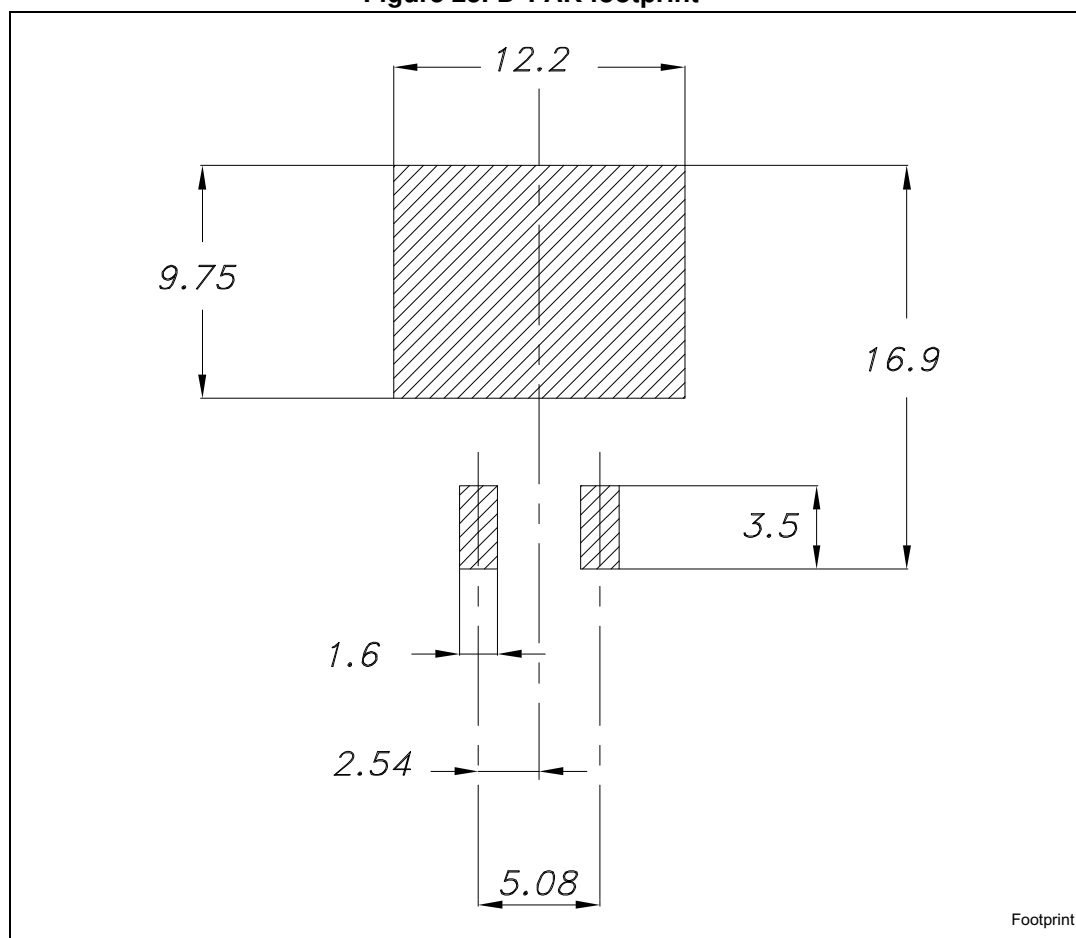

Table 9. D²PAK mechanical data

| Dim. | mm | | |
|------|------|------|-------|
| | Min. | Typ. | Max. |
| A | 4.40 | | 4.60 |
| A1 | 0.03 | | 0.23 |
| b | 0.70 | | 0.93 |
| b2 | 1.14 | | 1.70 |
| c | 0.45 | | 0.60 |
| c2 | 1.23 | | 1.36 |
| D | 8.95 | | 9.35 |
| D1 | 7.50 | 7.75 | 8.00 |
| D2 | 1.10 | 1.30 | 1.50 |
| E | 10 | | 10.40 |
| E1 | 8.50 | 8.70 | 8.90 |
| E2 | 6.85 | 7.05 | 7.25 |
| e | | 2.54 | |
| e1 | 4.88 | | 5.28 |
| H | 15 | | 15.85 |
| J1 | 2.49 | | 2.69 |
| L | 2.29 | | 2.79 |
| L1 | 1.27 | | 1.40 |
| L2 | 1.30 | | 1.75 |
| R | | 0.4 | |
| V2 | 0° | | 8° |

Figure 25. D²PAK footprint (a)



a. All dimensions are in millimeters

4.2 TO-220FP, STF28N65M2

Figure 26. TO-220FP drawing

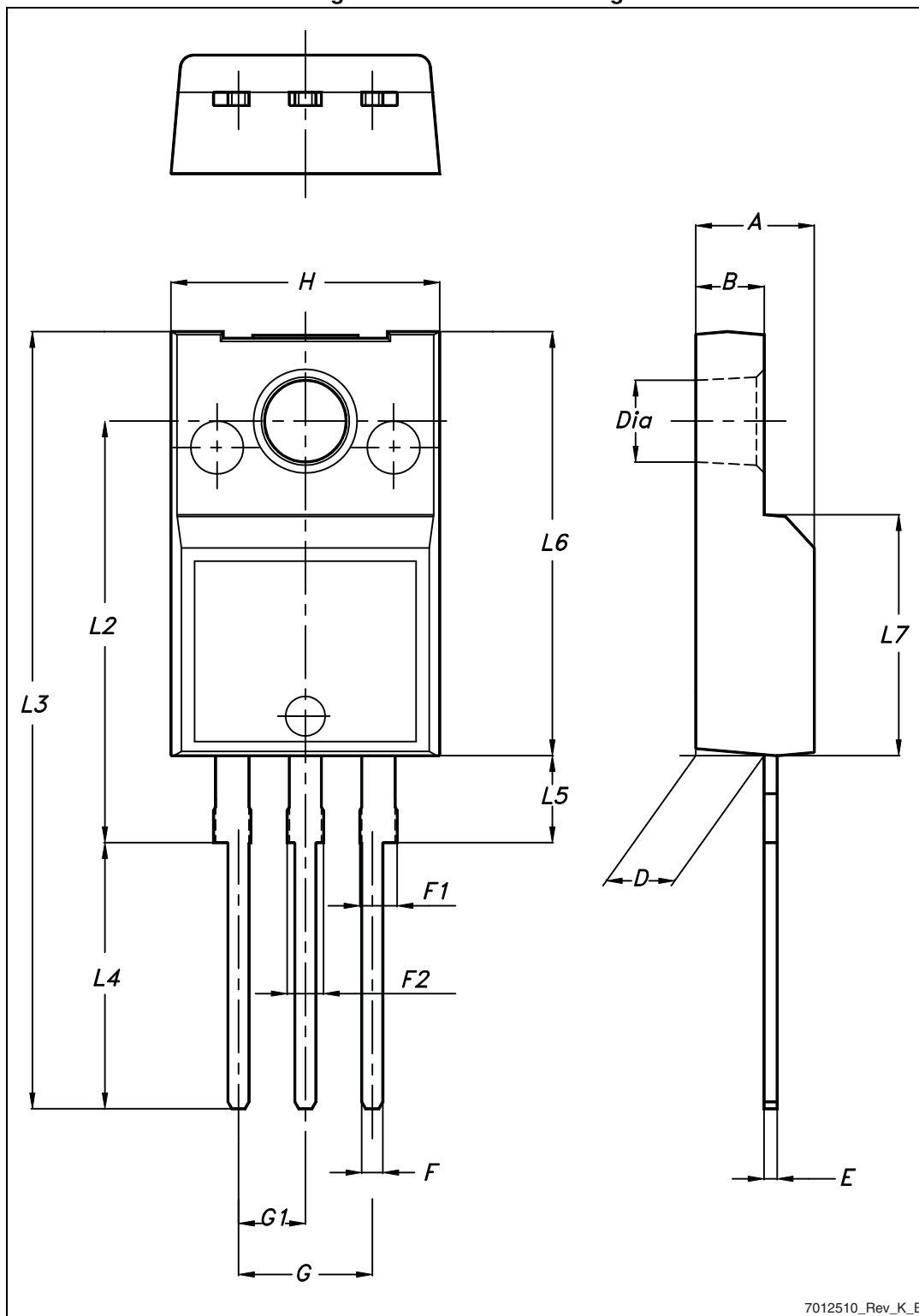

7012510_Rev_K_B

Table 10. TO-220FP mechanical data

| Dim. | mm | | |
|------|------|------|------|
| | Min. | Typ. | Max. |
| A | 4.4 | | 4.6 |
| B | 2.5 | | 2.7 |
| D | 2.5 | | 2.75 |
| E | 0.45 | | 0.7 |
| F | 0.75 | | 1 |
| F1 | 1.15 | | 1.70 |
| F2 | 1.15 | | 1.70 |
| G | 4.95 | | 5.2 |
| G1 | 2.4 | | 2.7 |
| H | 10 | | 10.4 |
| L2 | | 16 | |
| L3 | 28.6 | | 30.6 |
| L4 | 9.8 | | 10.6 |
| L5 | 2.9 | | 3.6 |
| L6 | 15.9 | | 16.4 |
| L7 | 9 | | 9.3 |
| Ø | 3 | | 3.2 |

4.3 TO-220, STP28N65M2

Figure 27. TO-220 type A drawing

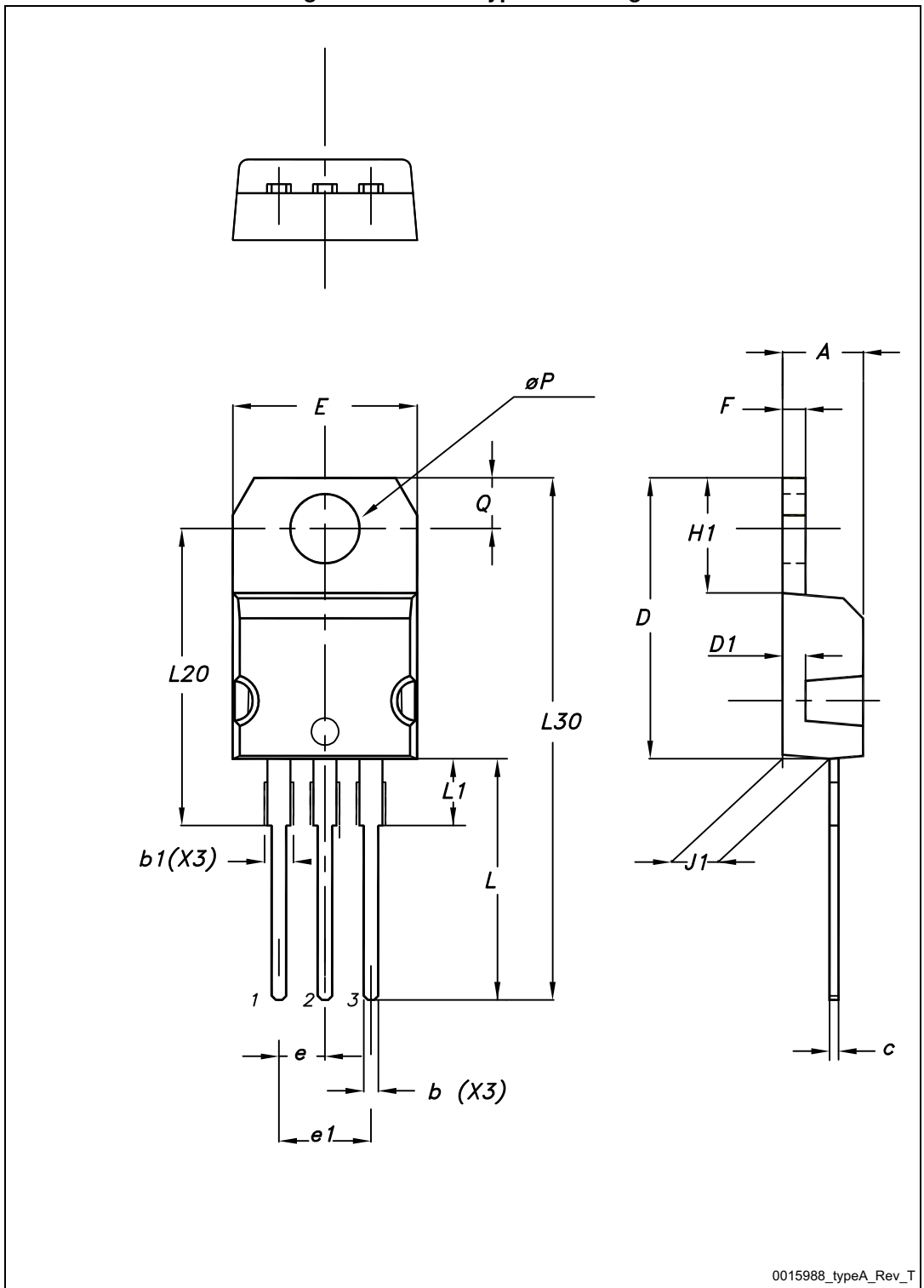

Table 11. TO-220 type A mechanical data

| Dim. | mm | | |
|------|-------|-------|-------|
| | Min. | Typ. | Max. |
| A | 4.40 | | 4.60 |
| b | 0.61 | | 0.88 |
| b1 | 1.14 | | 1.70 |
| c | 0.48 | | 0.70 |
| D | 15.25 | | 15.75 |
| D1 | | 1.27 | |
| E | 10 | | 10.40 |
| e | 2.40 | | 2.70 |
| e1 | 4.95 | | 5.15 |
| F | 1.23 | | 1.32 |
| H1 | 6.20 | | 6.60 |
| J1 | 2.40 | | 2.72 |
| L | 13 | | 14 |
| L1 | 3.50 | | 3.93 |
| L20 | | 16.40 | |
| L30 | | 28.90 | |
| ∅P | 3.75 | | 3.85 |
| Q | 2.65 | | 2.95 |

4.4 TO-247, STW28N65M2

Figure 28. TO-247 drawing

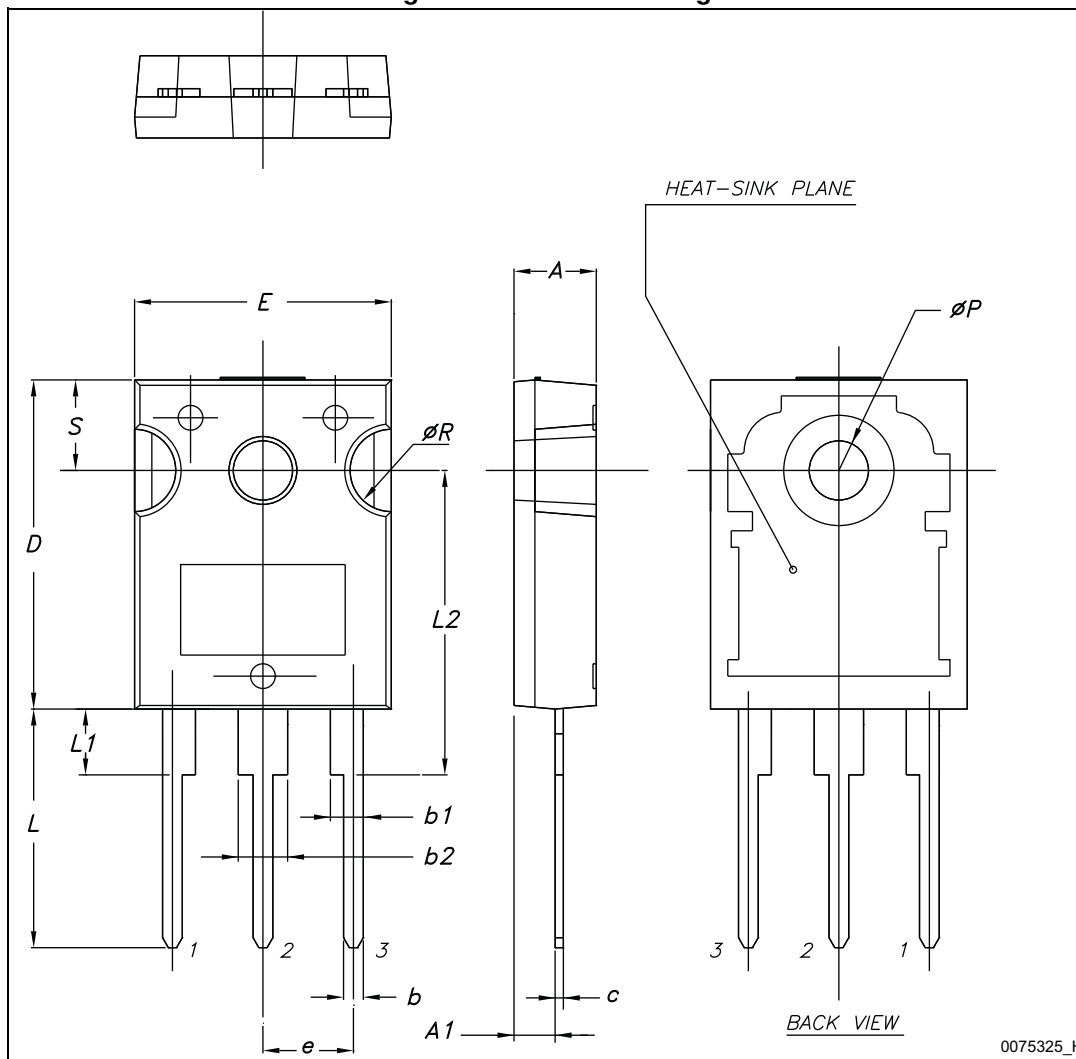

Table 12. TO-247 mechanical data

| Dim. | mm. | | |
|------|-------|-------|-------|
| | Min. | Typ. | Max. |
| A | 4.85 | | 5.15 |
| A1 | 2.20 | | 2.60 |
| b | 1.0 | | 1.40 |
| b1 | 2.0 | | 2.40 |
| b2 | 3.0 | | 3.40 |
| c | 0.40 | | 0.80 |
| D | 19.85 | | 20.15 |
| E | 15.45 | | 15.75 |
| e | 5.30 | 5.45 | 5.60 |
| L | 14.20 | | 14.80 |
| L1 | 3.70 | | 4.30 |
| L2 | | 18.50 | |
| ØP | 3.55 | | 3.65 |
| ØR | 4.50 | | 5.50 |
| S | 5.30 | 5.50 | 5.70 |

5 Packing mechanical data

Figure 29. Tape for D²PAK

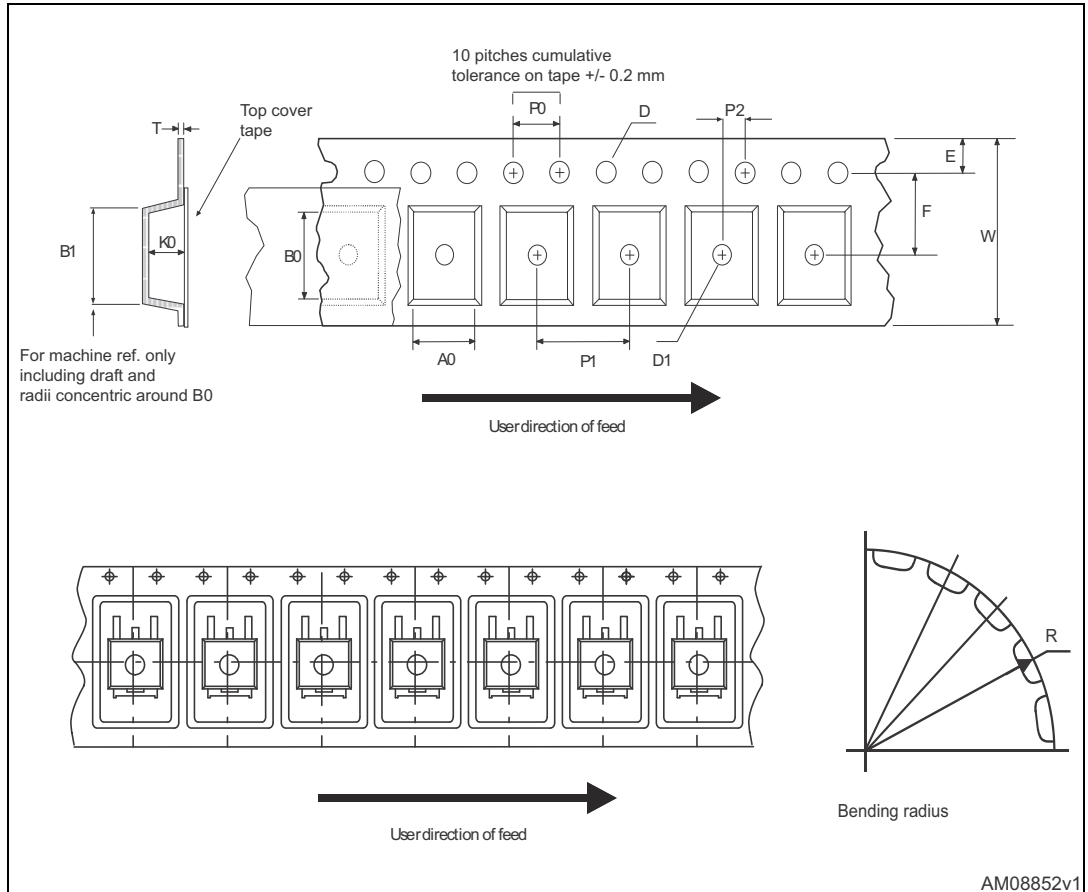

Figure 30. Reel for D²PAK

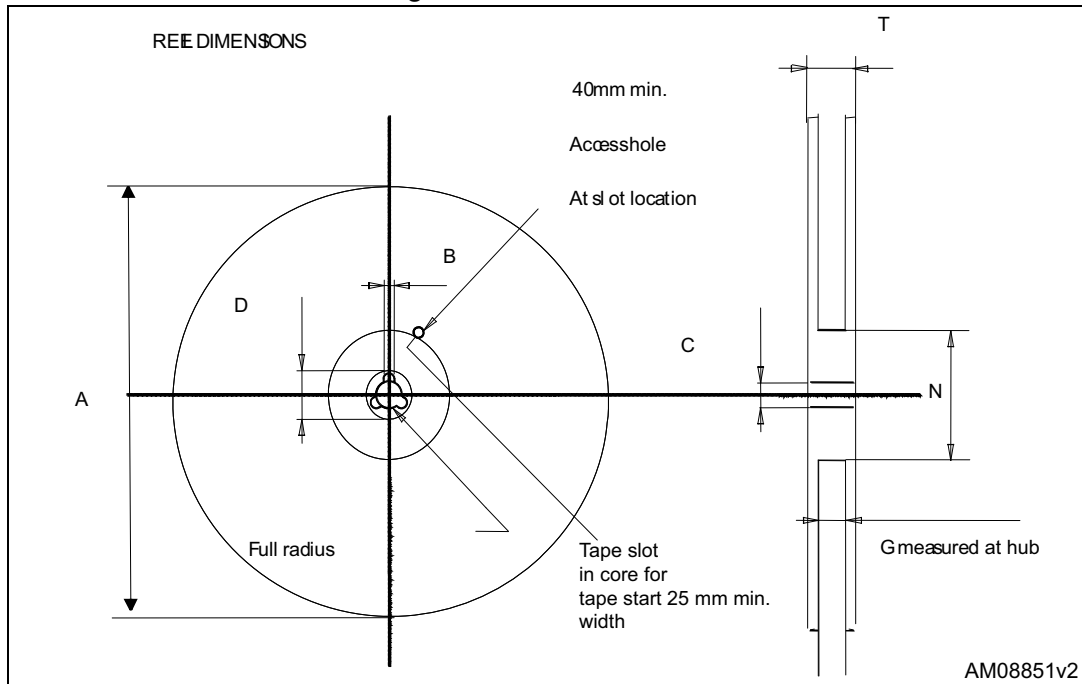

Table 13. D²PAK tape and reel mechanical data

| Tape | | | Reel | | |
|------|------|------|----------|------|------|
| Dim. | mm | | Dim. | mm | |
| | Min. | Max. | | Min. | Max. |
| A0 | 10.5 | 10.7 | A | | 330 |
| B0 | 15.7 | 15.9 | B | 1.5 | |
| D | 1.5 | 1.6 | C | 12.8 | 13.2 |
| D1 | 1.59 | 1.61 | D | 20.2 | |
| E | 1.65 | 1.85 | G | 24.4 | 26.4 |
| F | 11.4 | 11.6 | N | 100 | |
| K0 | 4.8 | 5.0 | T | | 30.4 |
| P0 | 3.9 | 4.1 | | | |
| P1 | 11.9 | 12.1 | Base qty | | 1000 |
| P2 | 1.9 | 2.1 | Bulk qty | | 1000 |
| R | 50 | | | | |
| T | 0.25 | 0.35 | | | |
| W | 23.7 | 24.3 | | | |

6 Revision history

Table 14. Document revision history

| Date | Revision | Changes |
|-------------|----------|----------------|
| 09-Dec-2014 | 1 | First release. |

IMPORTANT NOTICE – PLEASE READ CAREFULLY

STMicroelectronics NV and its subsidiaries ("ST") reserve the right to make changes, corrections, enhancements, modifications, and improvements to ST products and/or to this document at any time without notice. Purchasers should obtain the latest relevant information on ST products before placing orders. ST products are sold pursuant to ST's terms and conditions of sale in place at the time of order acknowledgement.

Purchasers are solely responsible for the choice, selection, and use of ST products and ST assumes no liability for application assistance or the design of Purchasers' products.

No license, express or implied, to any intellectual property right is granted by ST herein.

Resale of ST products with provisions different from the information set forth herein shall void any warranty granted by ST for such product.

ST and the ST logo are trademarks of ST. All other product or service names are the property of their respective owners.

Information in this document supersedes and replaces information previously supplied in any prior versions of this document.

© 2014 STMicroelectronics – All rights reserved