

600V GaN FET PQFN Series

Description

The TPH3202L Series 600V, 290mΩ Gallium Nitride (GaN) FETs are normally-off devices. They combine state-of-the-art high voltage GaN HEMT and low voltage silicon MOSFET technologies—offering superior reliability and performance.

Transphorm GaN offers improved efficiency over silicon, through lower gate charge, lower crossover loss, and smaller reverse recovery charge.

Related Literature

- [AN0009](#): Recommended External Circuitry for GaN FETs
- [AN0003](#): Printed Circuit Board Layout and Probing

Product Series and Ordering Information

Part Number*	Package	Package Configuration
TPH3202LD	8 x 8mm PQFN	Drain
TPH3202LS	8 x 8mm PQFN	Source

* Add “-TR” suffix for tape and reel; see page 13

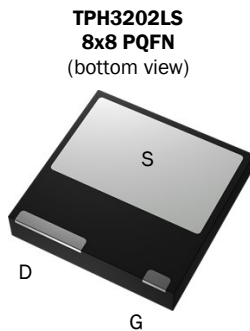
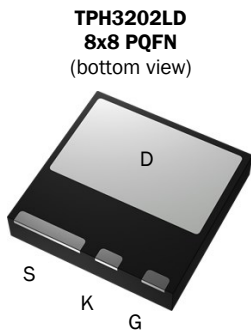

Features

- JEDEC qualified GaN technology
- Dynamic $R_{DS(on)eff}$ production tested
- Robust design, defined by
 - Intrinsic lifetime tests
 - Wide gate safety margin
 - Transient over-voltage capability
- Very low Q_{RR}
- Reduced crossover loss
- RoHS compliant and Halogen-free packaging

Benefits

- Enables AC-DC bridgeless totem-pole PFC designs
 - Increased power density
 - Reduced system size and weight
 - Overall lower system cost
- Achieves increased efficiency in both hard- and soft-switched circuits
- Easy to drive with commonly-used gate drivers

Applications

- Datacom
- Broad industrial
- PV inverter
- Servo motor

Key Specifications

V_{DSS} (V)	600
$V_{(TR)DSS}$ (V)	750
$R_{DS(on)eff}$ (mΩ) max*	350
Q_{RR} (nC) typ	29
Q_G (nC) typ	6.2

* Dynamic on-resistance; see Figures 19 and 20

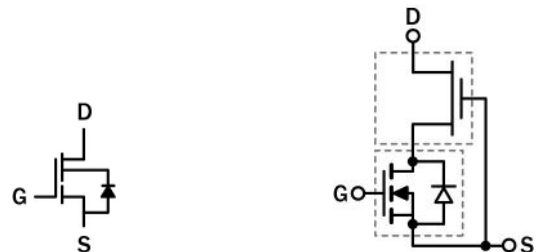

Cascade Schematic Symbol

Cascade Device Structure

TPH3202L Series—DISCONTINUED

Absolute Maximum Ratings ($T_c=25^\circ\text{C}$ unless otherwise stated.)

Symbol	Parameter	Limit Value	Unit	
V_{DSS}	Drain to source voltage ($T_J = -55^\circ\text{C}$ to 175°C)	600	V	
$V_{(TR)DSS}$	Transient drain to source voltage ^a	750		
V_{GSS}	Gate to source voltage	± 18		
P_D	Maximum power dissipation @ $T_c=25^\circ\text{C}$	65	W	
I_D	Continuous drain current @ $T_c=25^\circ\text{C}$ ^b	9	A	
	Continuous drain current @ $T_c=100^\circ\text{C}$ ^b	6	A	
I_{DM}	Pulsed drain current (pulse width: $10\mu\text{s}$)	35	A	
$(di/dt)_{RDMC}$	Reverse diode di/dt , repetitive ^c	1200	A/ μs	
$(di/dt)_{RDMT}$	Reverse diode di/dt , transient ^d	2300	A/ μs	
T_C	Operating temperature	Case	-55 to +150	$^\circ\text{C}$
T_J		Junction	-55 to +175	$^\circ\text{C}$
T_S	Storage temperature	-55 to +150	$^\circ\text{C}$	
T_{SOLD}	Soldering peak temperature ^e	260	$^\circ\text{C}$	

Notes:

- In off-state, spike duty cycle $D < 0.01$, spike duration $< 1\mu\text{s}$
- For increased stability at high current operation, see Circuit Implementation on page 3
- Continuous switching operation
- ≤ 300 pulses per second for a total duration ≤ 20 minutes
- For 10 sec., 1.6mm from the case

Thermal Resistance

Symbol	Parameter	Typical	Unit
$R_{\theta JC}$	Junction-to-case	2.3	$^\circ\text{C}/\text{W}$
$R_{\theta JA}$	Junction-to-ambient ^a	45	$^\circ\text{C}/\text{W}$

Notes:

- Device on one layer epoxy PCB for drain connection (vertical and without air stream cooling, with 6cm^2 copper area and $70\mu\text{m}$ thickness)

TPH3202L Series—DISCONTINUED

Circuit Implementation

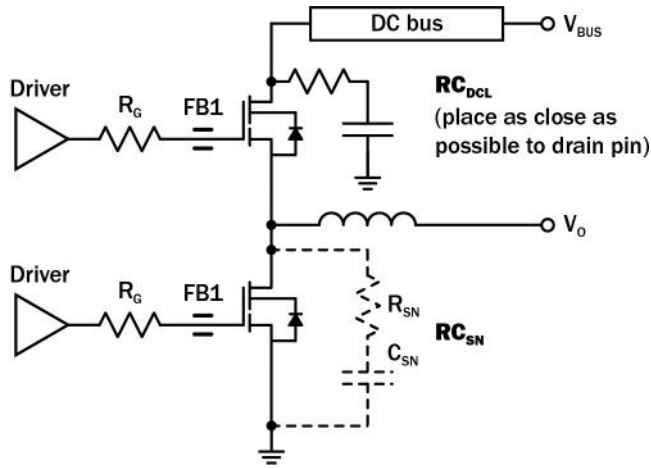

Simplified Half-bridge Schematic

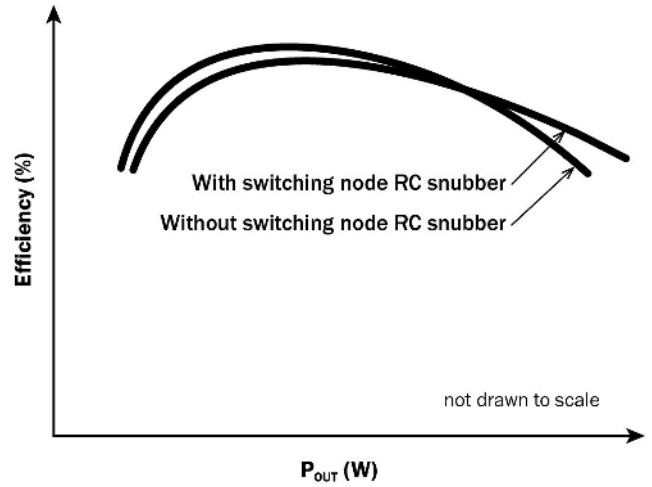

Efficiency vs Output Power

Recommended gate drive: (0V, 8-10V) with $R_{G(tot)} = 25\Omega$, where $R_{G(tot)} = R_G + R_{DRIVER}$

Gate Ferrite Bead (FB1)	Required DC Link RC Snubber (RC_{DCL}) ^a	Recommended Switching Node RC Snubber (RC_{SN}) ^{b, c}
MMZ1608Y600B	10nF + 8 Ω	15pF + 22 Ω

Notes:

- RC_{DCL} should be placed as close as possible to the drain pin
- A switching node RC snubber (C, R) is recommended for high switching currents (>70% of I_{RDMC1} or I_{RDMC2} ; see page 5 for I_{RDMC1} and I_{RDMC2})
- I_{RDM} values can be increased by increasing R_G and C_{SN}

TPH3202L Series—DISCONTINUED

Electrical Parameters (T_J=25 °C unless otherwise stated)

Symbol	Parameter	Min	Typ	Max	Unit	Test Conditions
Forward Device Characteristics						
V _{(BL)DSS}	Drain-source voltage	600	—	—	V	V _{GS} =0V
V _{GS(th)}	Gate threshold voltage	1.6	2	2.5	V	V _{DS} =V _{GS} , I _D =250μA
R _{DS(on)eff}	Drain-source on-resistance ^a	—	290	350	mΩ	V _{GS} =8V, I _D =5.5A
		—	670	—		V _{GS} =8V, I _D =5.5A, T _J =175 °C
I _{DSS}	Drain-to-source leakage current	—	2.5	90	μA	V _{DS} =600V, V _{GS} =0V
		—	8	—		V _{DS} =600V, V _{GS} =0V, T _J =150 °C
I _{GSS}	Gate-to-source forward leakage current	—	—	100	nA	V _{GS} =18V
	Gate-to-source reverse leakage current	—	—	-100		V _{GS} =-18V
C _{ISS}	Input capacitance	—	760	—	pF	V _{GS} =0V, V _{DS} =400V, f=1MHz
C _{OSS}	Output capacitance	—	28	—		
C _{RSS}	Reverse transfer capacitance	—	3.6	—		
C _{O(er)}	Output capacitance, energy related ^b	—	40	—	pF	V _{GS} =0V, V _{DS} =0V to 400V
C _{O(tr)}	Output capacitance, time related ^c	—	63	—		
Q _G	Total gate charge	—	6.2	9.3	nC	V _{DS} =400V, V _{GS} =0V to 8V, I _D =5.5A
Q _{GS}	Gate-source charge	—	2.1	—		
Q _{GD}	Gate-drain charge	—	2.2	—		
Q _{OSS}	Output charge	—	25.3	—	nC	V _{GS} =0V, V _{DS} =0V to 400V
t _{D(on)}	Turn-on delay	—	6.2	—	ns	V _{DS} =400V, V _{GS} =0V to 10V, I _D =5.5A, R _G =22Ω
t _R	Rise time	—	4.5	—		
t _{D(off)}	Turn-off delay	—	9.7	—		
t _F	Fall time	—	5	—		

Notes:

- Dynamic on-resistance; see Figures 19 and 20 for test circuit and conditions
- Equivalent capacitance to give same stored energy as V_{DS} rises from 0V to 400V
- Equivalent capacitance to give same charging time as V_{DS} rises from 0V to 400V

TPH3202L Series—DISCONTINUED

Electrical Parameters (T_J=25 °C unless otherwise stated)

Symbol	Parameter	Min	Typ	Max	Unit	Test Conditions
Reverse Device Characteristics						
I _S	Reverse current	—	—	6	A	V _{GS} =0V, T _C =100 °C, ≤25% duty cycle
V _{SD}	Reverse voltage ^a	—	2.9	—	V	V _{GS} =0V, I _S =6A
		—	4.8	—		V _{GS} =0V, I _S =6A, T _J =175 °C
		—	2.2	—		V _{GS} =0V, I _S =3A
t _{RR}	Reverse recovery time	—	11.5	—	ns	I _S =5.5A, V _{DD} =480V, di/dt=1500A/μs
Q _{RR}	Reverse recovery charge	—	29	—	nC	
(di/dt) _{RDMC}	Reverse diode di/dt, repetitive ^b	—	—	1200	A/μs	
I _{RDMC1}	Reverse diode switching current, repetitive (dc) ^{c, e}	—	—	8	A	Circuit implementation and parameters on page 3
I _{RDMC2}	Reverse diode switching current, repetitive (ac) ^{c, e}	—	—	10	A	Circuit implementation and parameters on page 3
(di/dt) _{RDMT}	Reverse diode di/dt, transient ^d	—	—	2300	A/μs	
I _{RDMT}	Reverse diode switching current, transient ^{d, e}	—	—	13	A	Circuit implementation and parameters on page 3

Notes:

- Includes dynamic R_{DS(on)} effect
- Continuous switching operation
- Definitions: dc = dc-to-dc converter topologies; ac = inverter and PFC topologies, 50-60Hz line frequency
- ≤300 pulses per second for a total duration ≤20 minutes
- I_{RDM} values can be increased by increasing R_G and C_{SN} on page 3

TPH3202L Series—DISCONTINUED

Typical Characteristics ($T_C=25^\circ\text{C}$ unless otherwise stated)

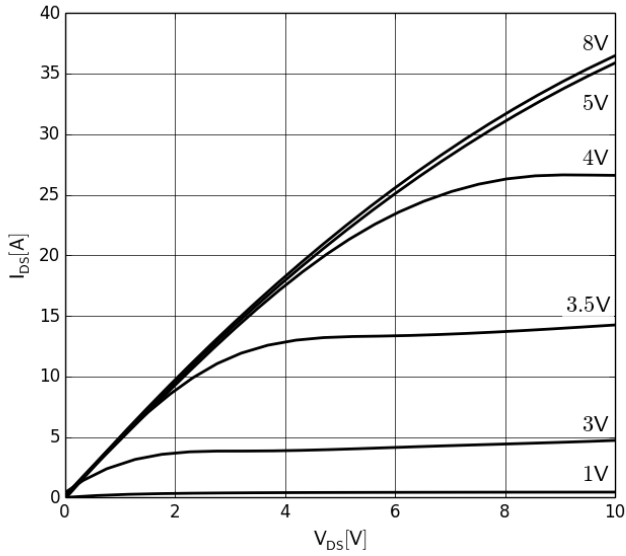

Figure 1. Typical Output Characteristics $T_J=25^\circ\text{C}$
Parameter: V_{GS}

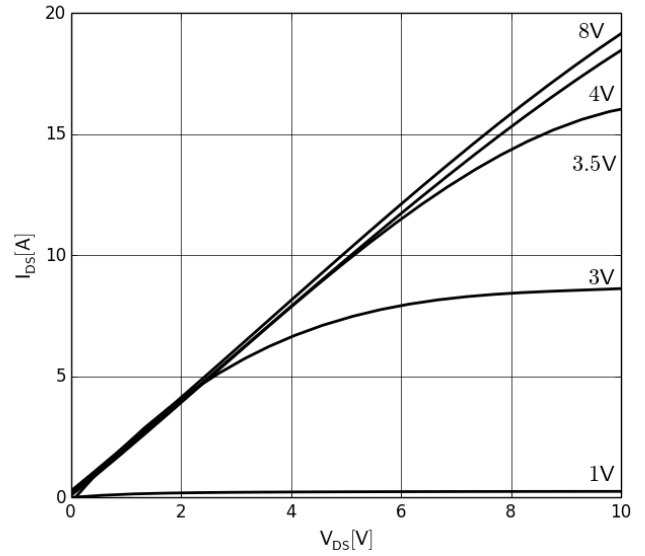

Figure 2. Typical Output Characteristics $T_J=175^\circ\text{C}$
Parameter: V_{GS}

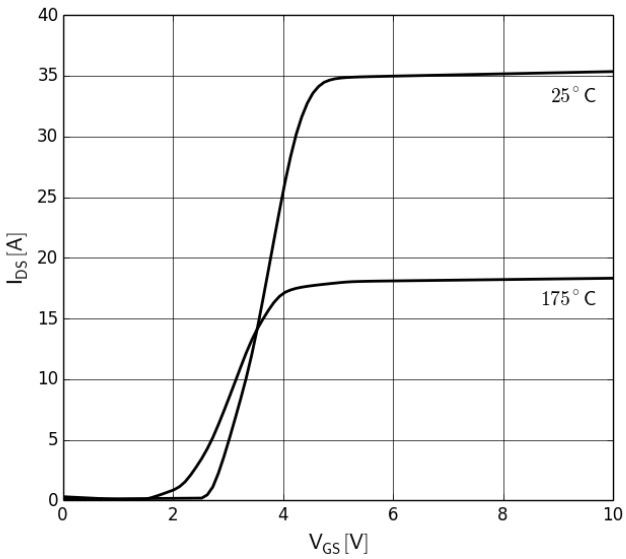

Figure 3. Typical Transfer Characteristics
 $V_{DS}=10\text{V}$, parameter: T_J

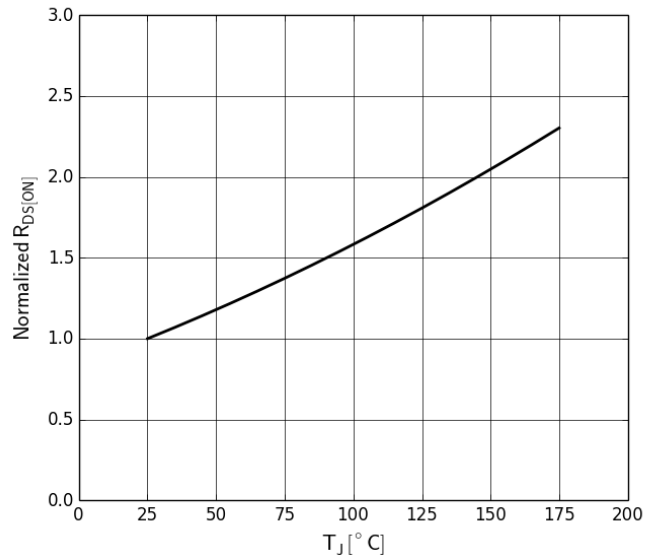

Figure 4. Normalized On-resistance
 $I_D=6\text{A}$, $V_{GS}=8\text{V}$

TPH3202L Series—DISCONTINUED

Typical Characteristics ($T_C=25^\circ\text{C}$ unless otherwise stated)

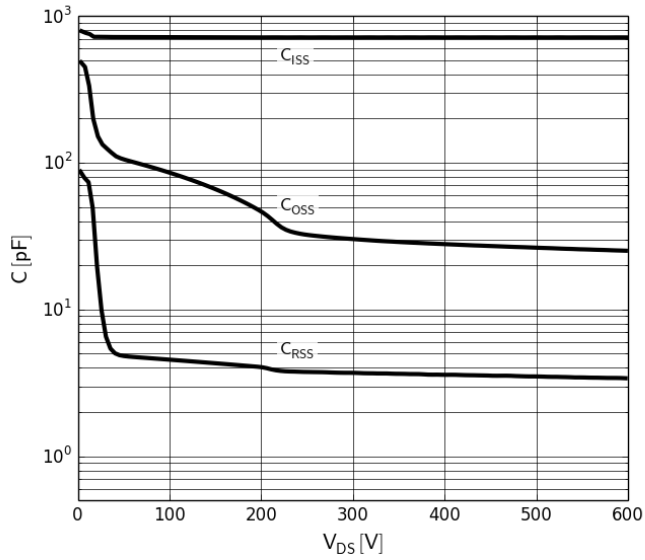

Figure 5. Typical Capacitance

$V_{GS}=0V$, $f=1\text{MHz}$

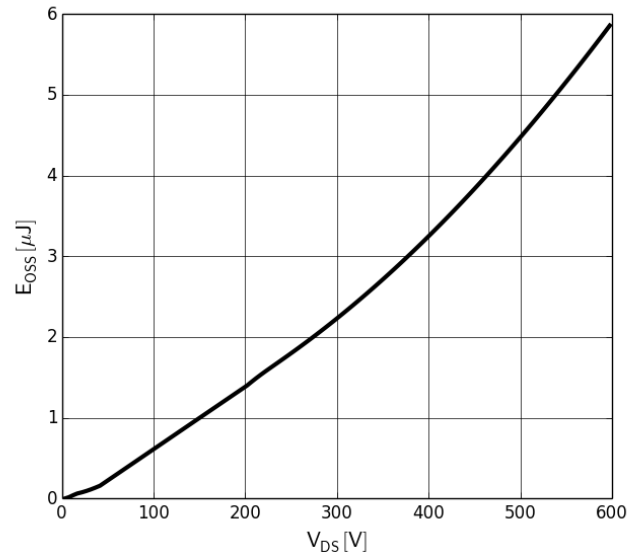

Figure 6. Typical C_{oss} Stored Energy

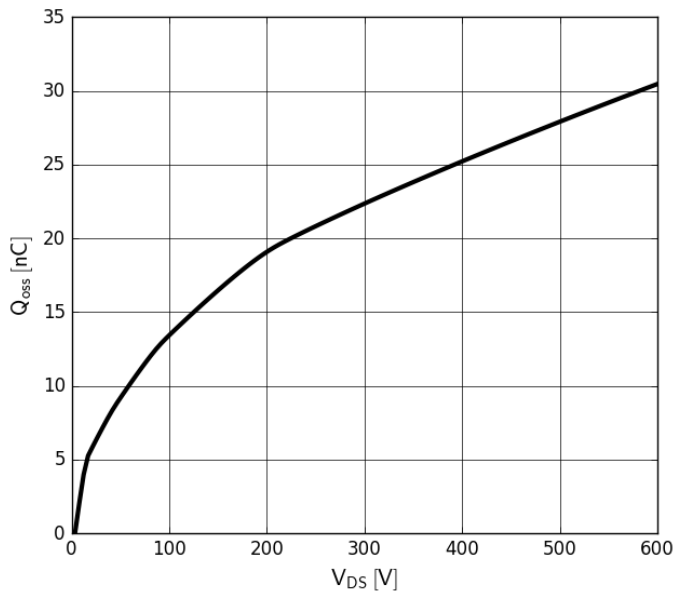

Figure 7. Typical Q_{oss}

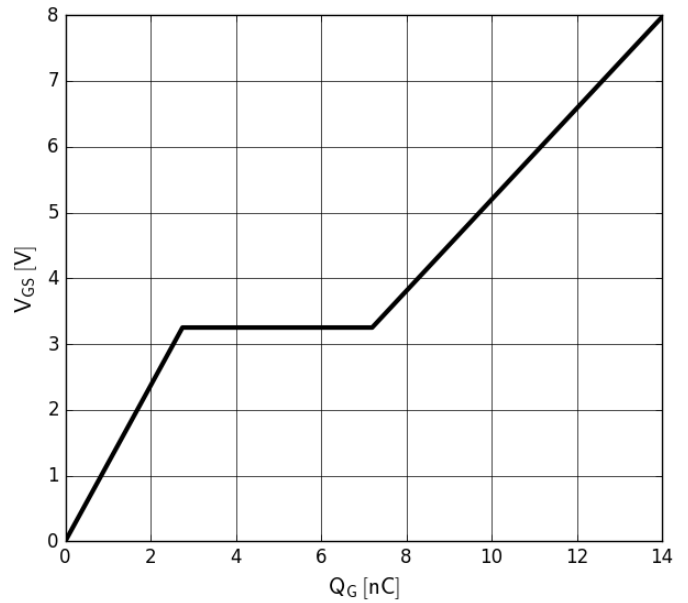

Figure 8. Typical Gate Charge

$I_{DS}=6A$, $V_{DS}=400V$

TPH3202L Series—DISCONTINUED

Typical Characteristics ($T_C=25^\circ\text{C}$ unless otherwise stated)

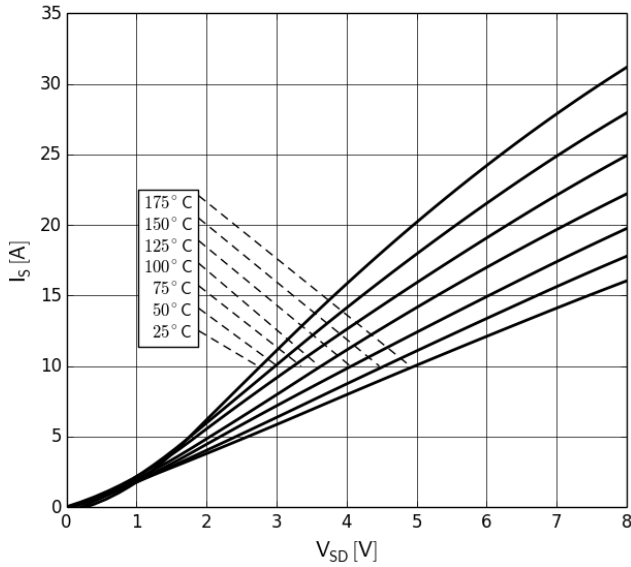

Figure 9. Forward Characteristics of Rev. Diode
 $I_S=f(V_{SD})$, parameter: T_J

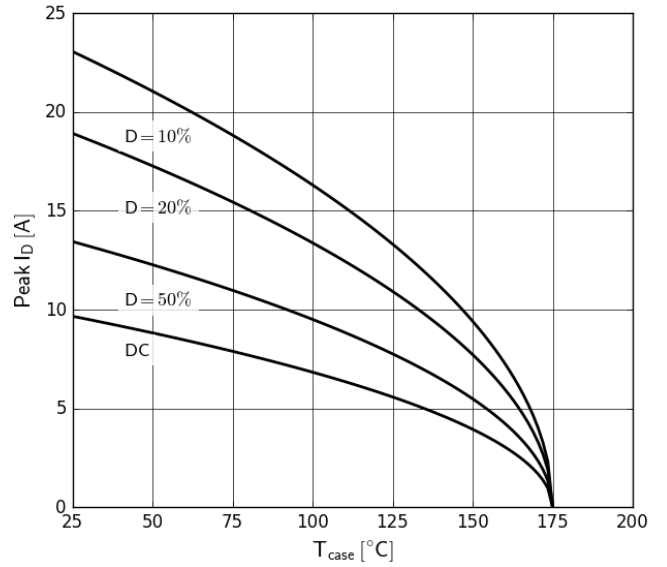

Figure 10. Current Derating
 Pulse width $\leq 100\mu\text{s}$

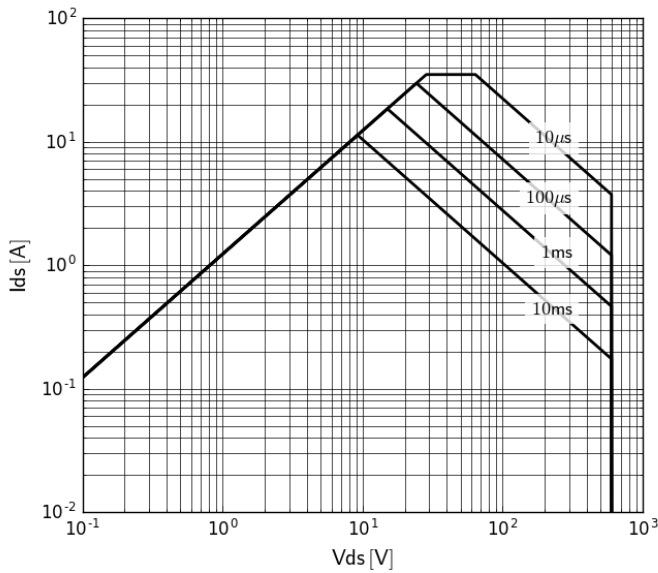

Figure 11. Safe Operating Area $T_C=25^\circ\text{C}$
 (calculated based on thermal limit)

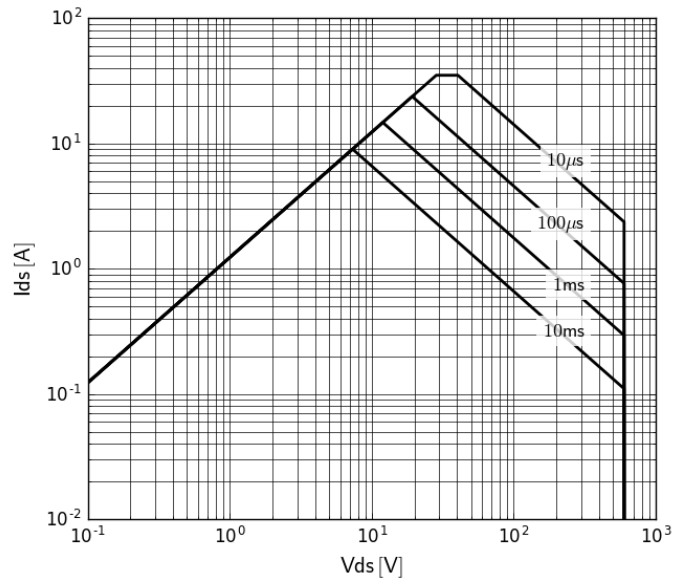

Figure 12. Safe Operating Area $T_C=80^\circ\text{C}$
 (calculated based on thermal limit)

TPH3202L Series—DISCONTINUED

Typical Characteristics ($T_C=25^\circ\text{C}$ unless otherwise stated)

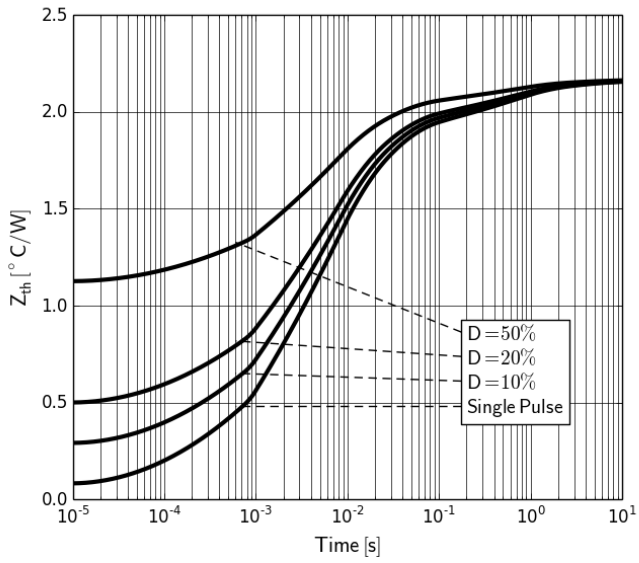

Figure 13. Transient Thermal Resistance

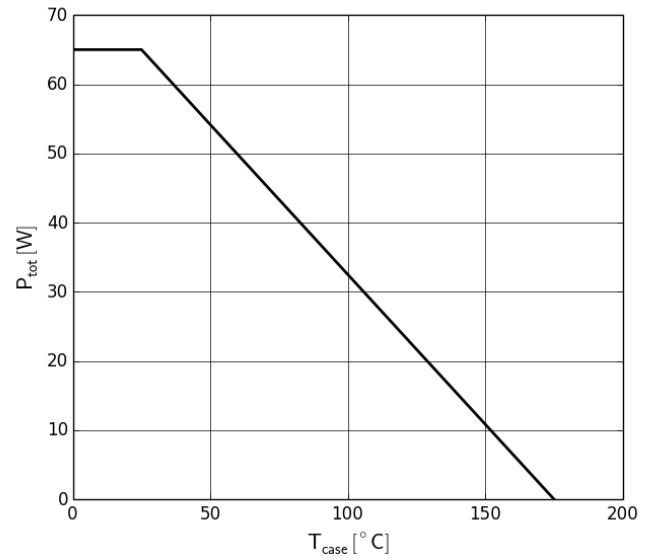

Figure 14. Power Dissipation

TPH3202L Series—DISCONTINUED

Test Circuits and Waveforms

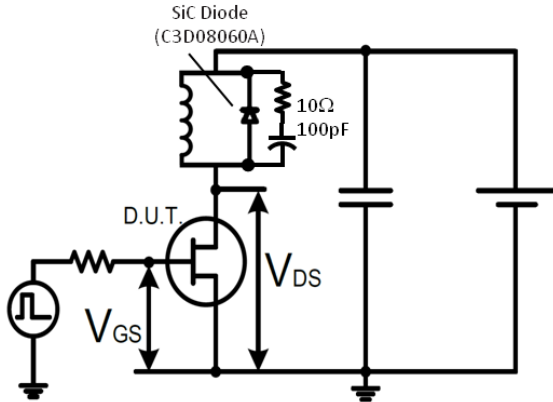

Figure 15. Switching Time Test Circuit
(see circuit implementation on page 3 for methods to ensure clean switching)

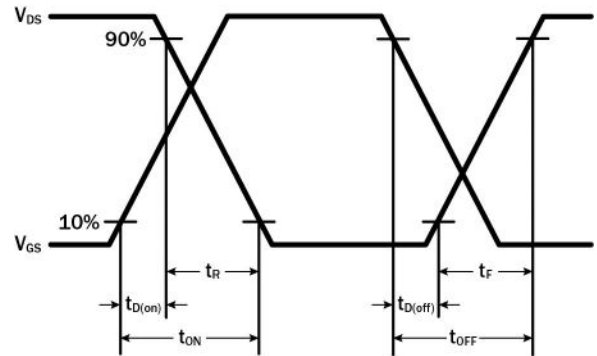

Figure 16. Switching Time Waveform

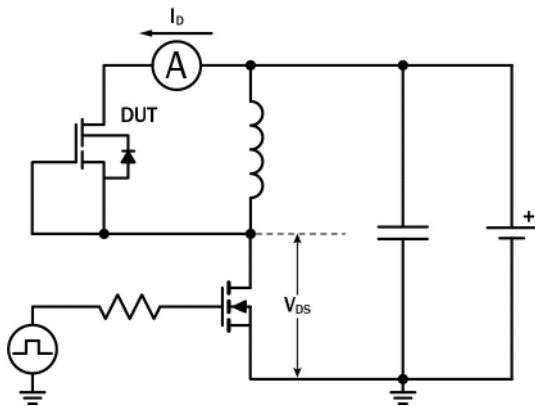

Figure 17. Diode Characteristics Test Circuit

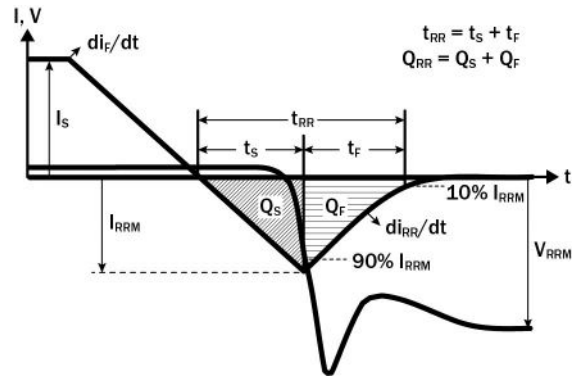

Figure 18. Diode Recovery Waveform

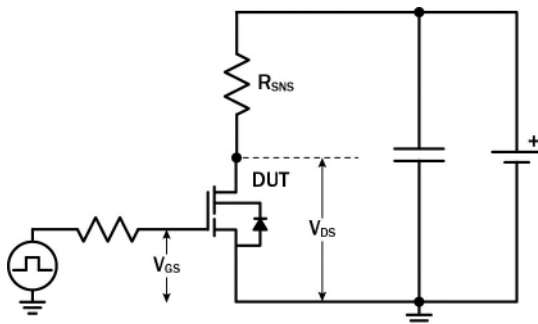

Figure 19. Dynamic $R_{DS(on)eff}$ Test Circuit

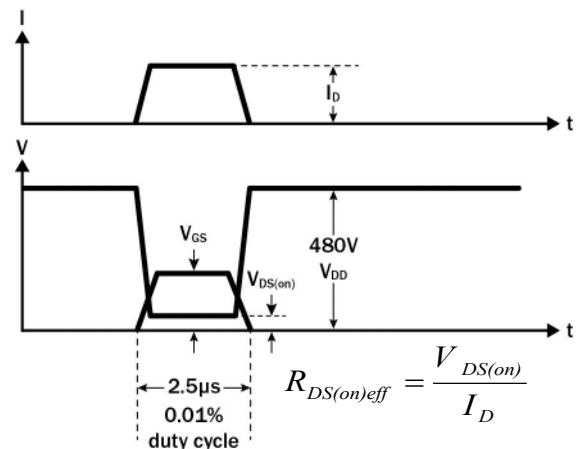

Figure 20. Dynamic $R_{DS(on)eff}$ Waveform

TPH3202L Series—DISCONTINUED

Design Considerations

The fast switching of GaN devices reduces current-voltage crossover losses and enables high frequency operation while simultaneously achieving high efficiency. However, taking full advantage of the fast switching characteristics of GaN switches requires adherence to specific PCB layout guidelines and probing techniques.

Before evaluating Transphorm GaN devices, see application note [Printed Circuit Board Layout and Probing for GaN Power Switches](#). The table below provides some practical rules that should be followed during the evaluation.

When Evaluating Transphorm GaN Devices:

DO	DO NOT
Minimize circuit inductance by keeping traces short, both in the drive and power loop	Twist the pins of TO-220 or TO-247 to accommodate GDS board layout
Minimize lead length of TO-220 and TO-247 package when mounting to the PCB	Use long traces in drive circuit, long lead length of the devices
Use shortest sense loop for probing; attach the probe and its ground connection directly to the test points	Use differential mode probe or probe ground clip with long wire
See AN0003 : Printed Circuit Board Layout and Probing	

GaN Design Resources

The complete technical library of GaN design tools can be found at transphormusa.com/design:

- Reference designs
- Evaluation kits
- Application notes
- Design guides
- Simulation models
- Technical papers and presentations

TPH3202L Series—DISCONTINUED

Mechanical

8x8 PQFN (LD) Package

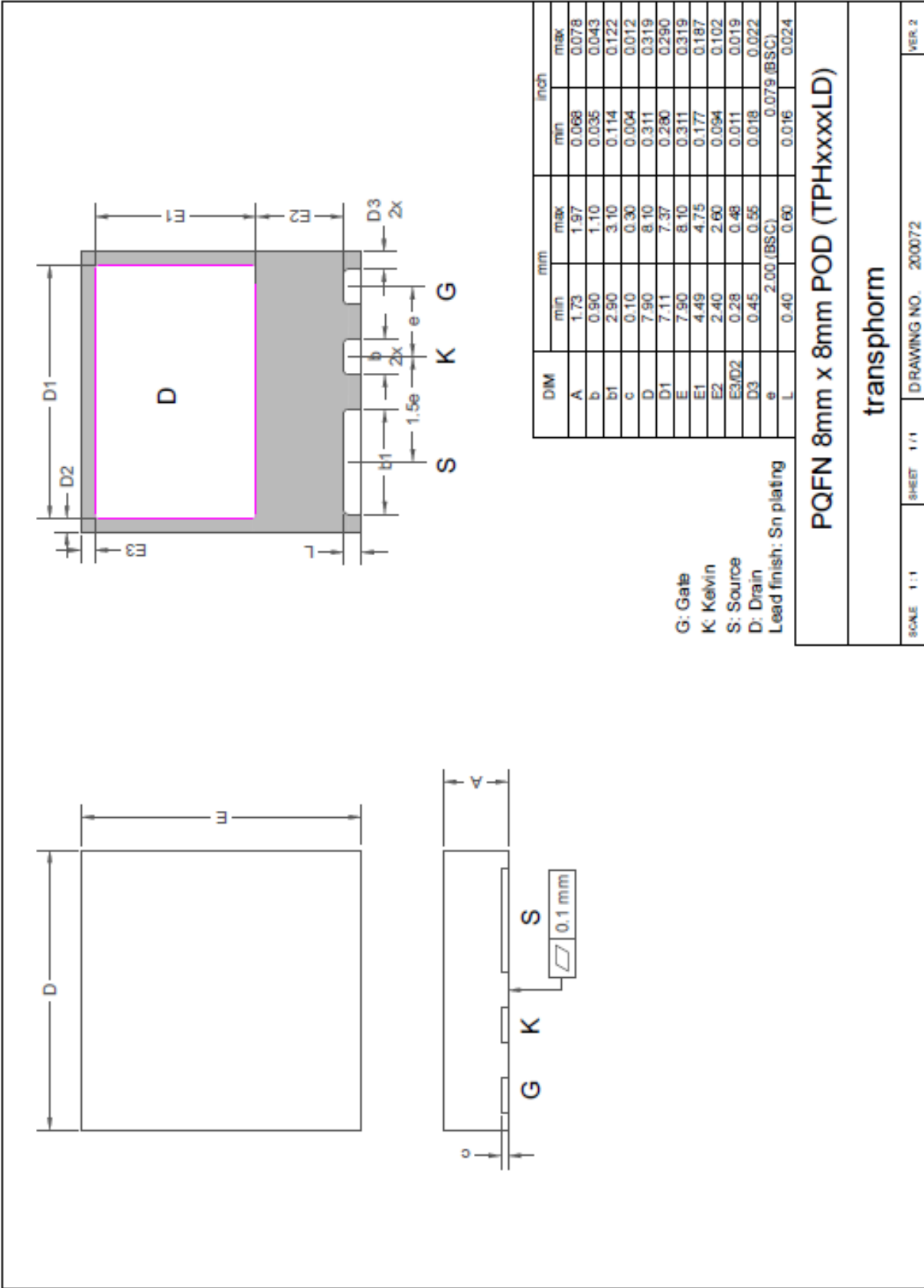

TPH3202L Series—DISCONTINUED

8x8 PQFN (LS) Package

Mechanical

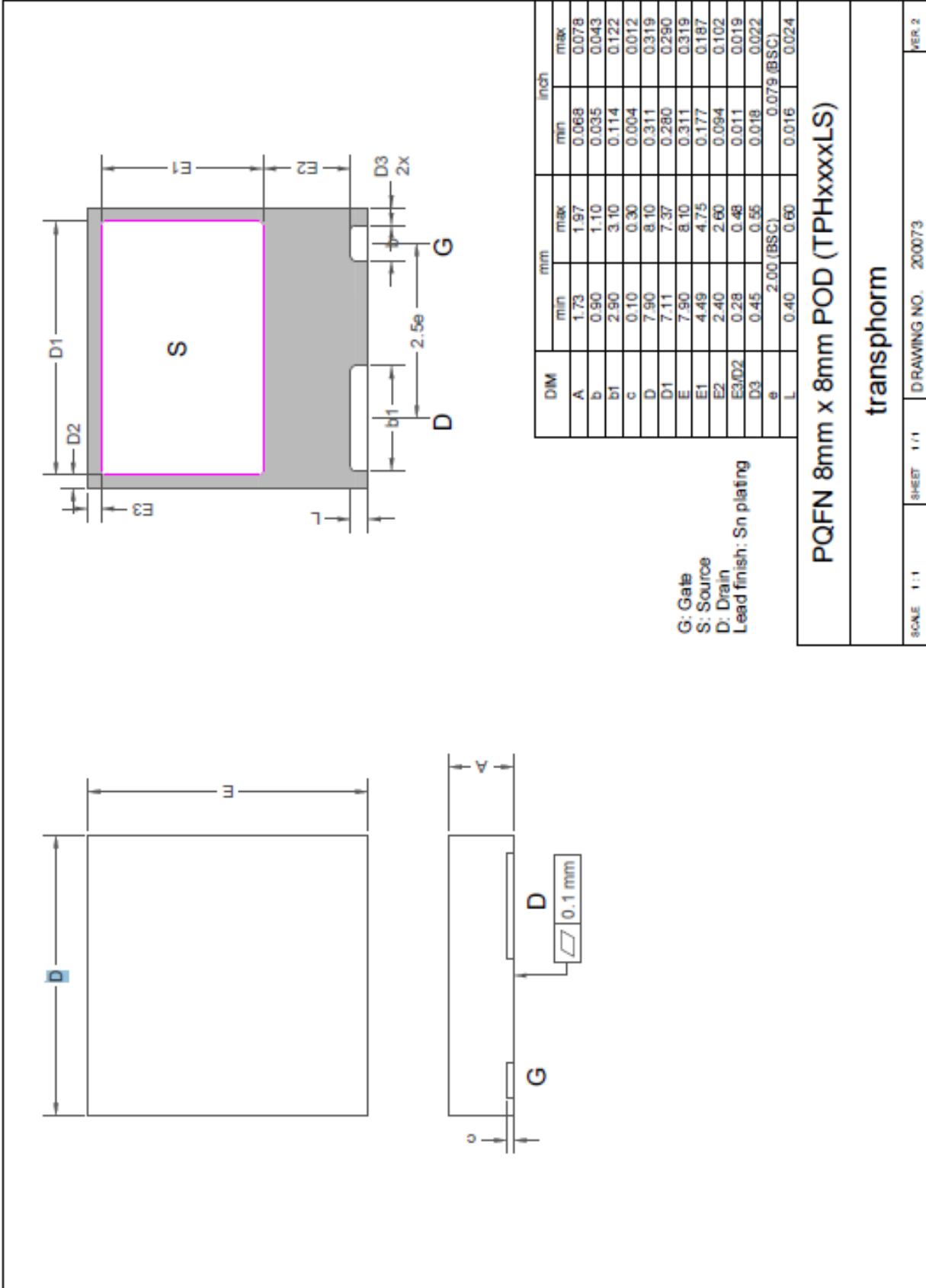

TPH3202L Series—DISCONTINUED

PQFN Tape and Reel Information

Product Orientation

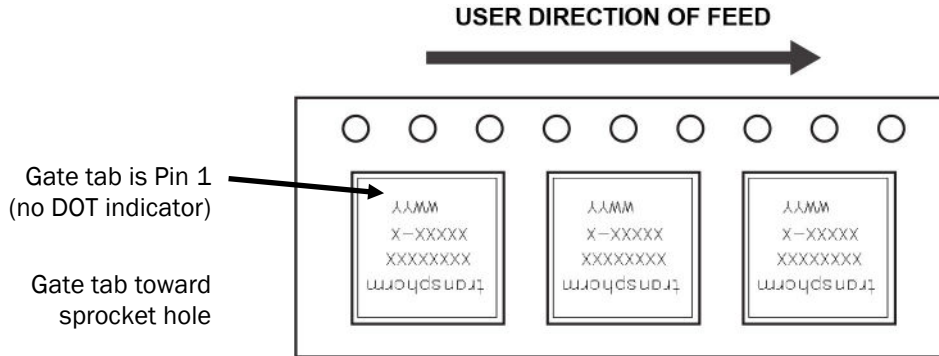

- Leader empty pockets: 400mm/15.75" min
- Trailer empty pickets: 160mm/6.3" min
- Quantity per reel: 500 pcs

Carrier Tape Dimension

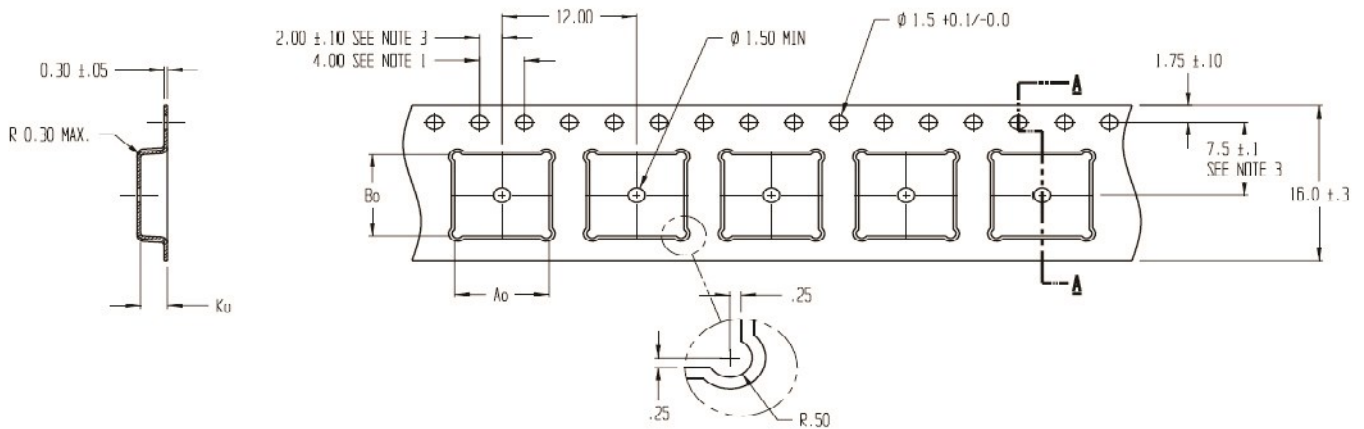

$A_o = 0.40$
 $B_o = 0.40$
 $K_o = 2.40$

- NOTES:
1. TO SPROCKET HOLE PITCH CUMULATIVE TOLERANCE ± 0.2
 2. CAMBER IN COMPLIANCE WITH EIA 481
 3. POCKET POSITION RELATIVE TO SPROCKET HOLE MEASURED AS TRUE POSITION OF POCKET, NOT POCKET HOLE

TPH3202L Series—DISCONTINUED

Revision History

Version	Date	Change(s)
0	11/14/2016	Release L series datasheet
1	3/22/2017	Updated dynamic measurement verbiage
2	11/7/2017	Updated Figures 11 & 12 (pg 7), CV data to 400V values, effective on-resistance symbol to $R_{DS(on)eff}$ to adhere to new JEDEC standards; Added switching current values (pg 2), Circuit Implementation (pg 3), Q_{oss} value (pg 4), Figures 7 & 8 (pg 6)
3	3/27/2018	Product discontinued